

MOHRMAN, KAARDAL & ERICKSON, P.A.

ATTORNEYS AND COUNSELORS AT LAW

150 SOUTH FIFTH STREET
SUITE 3100
MINNEAPOLIS, MINNESOTA 55402

ERICK G. KAARDAL

TELEPHONE: 612/465-0927
FACSIMILE: 612/341-1076
WRITER'S E-MAIL: KAARDAL@MKLAW.COM

April 21, 2021

Via U.S. Mail

Wisconsin Elections Commission
212 East Washington Avenue,
Third Floor
P.O. Box 7984
Madison WI 53707-7984

WEC 23APR2021 AM09:19

Re: *Wisconsin Elections Commission Complaint*
In the Matter of: City of Racine 2020 and Future Elections

Dear all:

Please find enclosed for filing a complaint and supporting appendix. By copy of this letter, I am also serving the complaint and supporting appendix on the respondents.

Sincerely,

/s/ Erick G. Kaardal

Erick G. Kaardal

EGK/mg

cc: Administrator Meagan Wolfe, WEC
Hon. Cory Mason, Racine Mayor
Tara Coolidge, Racine City Clerk

ORIGINAL

**State of Wisconsin
Before the Wisconsin Elections Commission**

The Verified Complaint of

Martin Prujansky
1635 College Ave
Racine WI 53403

Mary Imhof Prujansky
1635 College Ave
Racine WI 53403

Kenneth Brown
217 Gaslight Circle
Racine WI 53403
Mailing address:
341 Main Street #8
Racine WI 53408

Brooke Hesse
3920 16th Street
Racine WI 53405

Dale Giles
2218 Jerome Blvd.
Racine WI 53403

Against Complaint Respondents

Administrator Meagan Wolfe
Wisconsin Elections Commission
212 East Washington Avenue, Third Floor
P.O. Box 7984
Madison, Wisconsin 53707-7984

Hon. Cory Mason
Mayor
City of Racine
730 Washington Ave
Racine, WI 53403

Tara Coolidge
City Clerk
730 Washington Ave
Room 103
Racine, WI 53403

This complaint is made under Wisconsin Statutes § 5.06.

We, the complainants Martin Prujansky, Mary Imhof Prujansky, Kenneth Brown, Brooke Hesse and Dale Giles allege, based on personal knowledge or upon information and belief, that:

Introduction

The Wisconsin Legislature expressly assigned to the Wisconsin Elections Commission “the responsibility for the administration of ... laws relating to elections,” Wisconsin Statutes § 5.05(1). *Trump v. Wisconsin Elections Commission*, 983 F.3d 919, 927 (7th Cir. 2020). The Commission’s Administrator, Meagan Wolfe, even as recently as March 31, 2020, before the General Assembly’s Campaigns and Elections Committee, publicly supported Wisconsin cities adopting private corporate conditions on state and federal elections without the Commission’s prior determination of the legality of imposing private corporate entity conditions upon existing state and federal election laws.¹

In the November 2020 general election, the City of Racine adopted private corporation conditions on the election process affecting state and federal elections. In this case, Racine involved private corporations and their employees in the City’s state and federal

¹ Wisconsin Assembly Committee on Campaigns and Elections, “Informational Hearing on General Election Review.” Meagan Wolfe. Mar. 31, 2021. <https://wiseye.org/2021/03/31/assembly-committee-on-campaigns-and-elections-14/> accessed Apr. 6, 2021.

election administration. By doing so, Racine failed to comply with state laws, including obtaining from the Commission a prior determination of the legality of the private corporate conditions in the election process, and failed to comply with the U.S. Constitution's Elections and Electors Clauses which guarantee the state Legislature the exclusive role in approving Wisconsin's legal conditions relating to federal elections.

In March of 2021, Wisconsin Open Records Act (Wisconsin Statutes §19.31, et seq.) requests relating to Wisconsin election administration and Wisconsin legislative hearing testimony relating to election administration, revealed to the Complainants that Racine officials, responsible for the election process and procedures, adopted and implemented private corporate conditions, including direct corporate and corporate employee engagement in the administration of the general election.² Moreover, Complainants found that Racine Mayor Cory Mason, in his official capacity as Mayor, recruited four other cities—Milwaukee, Madison, Kenosha and Green Bay—to place the same corporate conditions on their election administration. The five cities and the private corporations began to refer to themselves as the “Wisconsin Five.”

The State Legislature never gave municipalities the authority to adopt or accept private corporate conditions affecting existing state election laws. The Commission, as the responsible entity in the administration of election laws, never opined on the legality of

²App. 1-482. Subsequent page references are to the appendix unless otherwise noted. The appendix has been provided because virtually all of the complaint's allegations are based on information found in government documents produced by Racine and other Wisconsin municipalities. For the purposes of the complaint, the complainants have presumed the government's documents are authentic. The complaint's inferences from the emails are based upon information and belief.

private corporate conditions affecting existing election laws. The Complainants allege that the Administrator's and Racine's actions violate state law and the U.S. Constitution's Elections and the Electors Clauses because they diverted constitutional authority of the State Legislature and the Commission to private corporations and the approving municipality of Racine. Further, the Complainants allege that Racine and certain Racine officials may have violated state and federal laws when they accepted and adopted private corporate conditions and when they approved Racine's engagement of private corporations and their employees into Racine's election administration. The Commission must act to correct and restrain the Administrator and Racine from the Administrator's legal position that the Commission has no role when a municipality's actions could or do directly modify the conditions of the municipality's state and federal elections.

First, the Commission should declare that the Commission indeed *has* a role in the administration of election laws whenever a municipality seeks to adopt as policy or enter into an agreement of any kind with a private corporate entity that imposes conditions in exchange for moneys involving the election process and administration.

Second, the Commission should reiterate that the Administrator may not render a decision without the approval of the Commission related to the legality of any agreement between private corporate entities and municipalities related to imposing private corporate conditions on the administration of election laws.

Third, the Commission should investigate the circumstances and factual allegations asserted in this Complaint regarding the legality of Racine's acts and actions juxtaposed against state and federal election laws to ascertain whether those election laws were violated.

Fourth, the Commission should consider any further prosecutorial investigation be directed to the proper local or state authorities.

Finally, if the Commission determines that election laws were violated or that the law is unclear to provide the Commission itself with the ability to determine the legalities of private corporate conditions directly or indirectly affecting the election process and administration, the Commission should make recommendations to the State Legislature for changes to state election laws to ensure the future integrity of the election process.

Complainants

1. Martin Prufansky is a Wisconsin elector residing at 1635 College Avenue, Racine, Wisconsin 53403.
2. Mary Imhof Prufansky is a Wisconsin elector residing at 1635 College Avenue, Racine, Wisconsin 53403.
3. Kenneth Brown is a Wisconsin elector residing at 217 Gaslight Circle, Racine, Wisconsin 53404 with a mailing address of 341 Main Street #8, Racine WI 53408.
4. Brooke Hesse is a Wisconsin elector residing at 3920 16th Street, Racine, Wisconsin 55405.
5. Dale Giles is a Wisconsin elector residing at 2218 Jerome Blvd., Racine, Wisconsin 53403.

Respondents

6. Meagan Wolfe is the Administrator of the Commission.
7. Respondent Cory Mason is the Mayor of the City of Racine.
8. Respondent Tara Coolidge is the Racine City Clerk.

Statement of Facts

9. The Wisconsin Legislature expressly assigned to the Commission “the responsibility for the administration of ... laws relating to elections,” Wisconsin Statutes § 5.05(1). *Trump v. Wisconsin Elections Commission*, 983 F.3d 919, 927 (7th Cir. 2020).

10. Under Wisconsin Statutes § 7.15(1), the municipal clerk has “charge and supervision” of federal elections within a municipality:

(1) SUPERVISE REGISTRATION AND ELECTIONS. Each municipal clerk has charge and supervision of elections and registration in the municipality...

11. The Commission and its municipal clerks, in administering elections in Wisconsin’s municipalities, are constitutionally obligated to follow the legal conditions set by the state legislature. Wis. Stat. §§ 5.05(1), 7.15(1).

12. The Elections Clause of the U.S. Constitution states that the state legislatures and Congress set the conditions for Congressional elections:

The Times, Places and Manner of holding Elections for Senators and Representatives, shall be prescribed in each State by the Legislature thereof; but the Congress may at any time by Law make or alter such Regulations, except as to the Places of chusing Senators.

U.S. Const., Art. I, § 4, cl. 1.

13. The Electors Clause of the U.S. Constitution states that the state legislatures exclusively set the conditions for choosing Presidential Electors:

Each State shall appoint, in such Manner as the Legislature thereof may direct, a Number of Electors, equal to the whole Number of Senators and Representatives to which the State may be entitled in the Congress.

U.S. Const., Art. II, § 1, cl. 2.

14. The Elections Clause and the Electors Clause provide no power to municipal governments to adopt private corporate conditions on federal elections or to introduce private corporations and their employees into federal election administration. U.S. Const., Art. I, § 4, cl. 1 and Art. II, § 1, cl. 2.

15. The City of Racine is incorporated under Wisconsin Statutes chapter 62.

16. Wisconsin cities are created by state statute and cannot exercise any power unless specifically provided for by statute:

The legislative power in this state is lodged in the legislature. When it exerts that power, it exerts it on behalf of and in the name of the people of the State of Wisconsin.” *Van Gilder v. City of Madison*, 222 Wis. 58, 67, 267 N.W. 25 (1936). Conversely, “cities are creatures of the state legislature [that] have no inherent right of self-government beyond the powers expressly granted to them.”

Black v. City of Milwaukee, 882 N.W.2d 333, 342–43 (Wis. 2016).

17. The Center for Tech and Civic Life (CTCL) is a private non-profit organization providing federal election grants to local governments, headquartered in Chicago, Illinois. (001-002)

18. For the 2020 federal election, CTCL was funded by private donations of more than \$300 million that were in turn used as conditional private grants to local governments.³

19. Nationally, CTCL funded local governments, cities and counties, with conditional private grants that were used for the 2020 general election. (001-002)

³“Mark Zuckerberg and Priscilla Chan are donating \$300 million to voting efforts.” Alexis Benveniste. Sept. 1, 2020.<https://www.cnn.com/2020/09/01/business/zuckerberg-300-million-voting/index.html> / accessed Apr. 6, 2021.

20. Certain urban local governments receiving CTCL grants agreed to the conditions of the grant in exchange for receiving CTCL moneys. (017-018; 393-394; 419-420)

21. These grants are contracts between each local government and CTCL. (017-018; 393-394; 419-420)

22. These conditional grants to the local government required reporting back to the private non-profit corporation, CTCL, regarding the moneys used for the 2020 general election. (018; 393; 419)

23. These conditional grants to the local government included claw-back provisions, requiring the local government to return the moneys to the private non-profit corporation, CTCL, if the private non-profit corporation disagreed how those moneys were spent in the conduct of the 2020 election. (018; 393; 419)

24. Upon information and belief, Racine Mayor Cory Mason communicated with CTCL about Racine and other Wisconsin cities accepting private corporate conditions on state and federal elections. (393-394)

25. Upon information and belief, Racine Mayor Cory Mason coordinated on accepting private corporate conditions on state and federal elections with Green Bay Mayor Genrich, Kenosha Mayor John Antaramian, Madison Mayor Satya Rhodes-Conway and Milwaukee Mayor Tom Barrett by having virtual meetings on the following days: May 16, 2020; June 13, 2020; and August 14, 2020. (464-482)

26. After the Wisconsin Five mayors began meeting, in early July 2020, CTCL issued a \$100,000 grant to the City of Racine to recruit other Wisconsin cities to join what the other four recruited cities and Racine would refer to as the “Wisconsin Safe Voting Plan.” (393-394)

27. Upon information and belief, Racine Mayor Cory Mason communicated with Mayors of other Wisconsin cities, including Green Bay, Madison, Milwaukee and Kenosha, about the \$100,000 grants and accepting private corporate conditions on state and federal elections. (393-394)

28. CTCL authorized the City of Racine to distribute from the \$100,000 grant, \$10,000 to each of the four recruited cities (keeping \$60,000 for itself), as an incentive for the Wisconsin Five Cities to participate in the CTCL conditional grants. (393-394).

29. The four cities Racine and its Mayor successfully recruited were Green Bay, Madison, Milwaukee, and Kenosha. (393-394; 395-415)

30. The so-called “Wisconsin Safe Voting Plan” was a grant application designed for the recruited five cities, Green Bay, Racine, Madison, Milwaukee, and Kenosha to request CTCL grant funding to support election administration activities during the COVID-19 pandemic. (395-415).

31. The “Safe Voting Plan” was developed “in the midst of the COVID-19 Pandemic” to ensure voting could be “done in accordance with prevailing public health requirements” to “reduce the risk of exposure to coronavirus.” Further, it was intended to assist with “a scramble to procure enough PPE to keep polling locations clean and disinfected.” (395-415).

32. The Cities of Madison, Green Bay, Racine, Kenosha and Milwaukee entered into the conditional grant agreements with CTCL. (395-415)

33. CTCL referred to the Cities of Madison, Green Bay, Racine, Kenosha and Milwaukee as the “WI-5” or the “Wisconsin Five” cities. (139-141).

34. However, it is the Commission that can provide “aid” to cities and counties for the administration of elections. Wis. Stat. §5.05(11).

35. Specifically, under Wisconsin Statutes §5.05(10), the Commission may render assistance to municipalities and counties via the state election administration plan that meets the requirements of the Help America Vote Act (Public Law 107–252) to enable participation by Wisconsin in federal assistance programs relating to elections.

36. As previously stated, with respect to elections, the Wisconsin State Legislature under Wisconsin Statutes § 5.05(1) delegated general authority to the Commission for the responsibility of administration of Wisconsin elections.

37. Whether moneys are received from other sources directly or indirectly related to the administration of elections, specifically wherein those moneys are conditional affecting existing election laws, the general authority and the jurisdiction of the Commission is engaged.

38. For instance, under Section 3 of the HAVA state administration plan, the Commission is “required to conduct regular training and administer examinations to ensure that individuals who are certified are knowledgeable concerning their authority and responsibilities.”

39. Upon information and belief, in May and June, 2020, the Cities of Racine, Madison, Green Bay, Milwaukee and Kenosha entered into a conditional grant agreement with CTCL for \$6,324,527. (017-018; 393-394; 419-420)

40. Under the terms of the CTCL conditional grant agreement, the five cities adopting the conditions would be required to remit back to CTCL the entire \$6,324,527 if CTCL, at its sole discretion, determined these cities had not complied with CTCL's terms. (017-018; 393-394; 419-420)

41. The CTCL Agreement provides that the purpose of the funds CTCL provided to the cities was to "be used exclusively for the public purpose of planning safe and secure election administration in the City of Racine in 2020, and coordinating such planning with other cities in Wisconsin." (017, 393, 419). The CTCL Agreement required these cities to develop a plan for their elections pursuant to the agreement by June 15, 2020. (017-018; 393-394; 419-420)

42. Wisconsin and federal election laws establish the manner in which elections are to be conducted. The administration of those laws is within the jurisdiction of the Commission; however, the administration must also be consistent with legislative or Congressional enactments.

43. On June 15, 2020, the Wisconsin Five cities presented their plan to CTCL. Among other things, these cities entered into agreements with CTCL to use the moneys to:

- Hire additional personnel for elections;
- Increase existing salaries for staff;
- Encourage and Increase Absentee Voting (by mail and early, in-person)

- Provide assistance to help voters comply with absentee ballot requests & certification requirements;
- Utilize secure drop-boxes to facilitate return of absentee ballots
- Deploy additional staff and/or technology improvements to expedite & improve accuracy of absentee ballot processing;
- Expand In-Person Early Voting (Including Curbside Voting); and
- Commit “to conducting the necessary voter outreach and education to promote absentee voting and encourage higher percentages of our electors to vote absentee.”

(395-415).

44. These provisions contained in the “Wisconsin Safe Voting Report,” which the Cities were required to adhere to, cannot be at or under direction of CTCL, in which case would be contrary to, or in-place of, or in addition to Wisconsin or federal election laws.

45. The “Wisconsin Safe Voting Report” (400-411) specifically provided that these Cities would be “promoting” and “encouraging higher percentages of our electors to vote absentee” which violates Wisconsin Statutes 6.84 (1) in which the State Legislature states:

The legislature finds that the privilege of voting by absentee ballot must be carefully regulated to prevent the potential for fraud or abuse; to prevent *overzealous solicitation of absent electors who may prefer not to participate in an election.*⁴

(emphasis added).

⁴ The reason for Wisconsin’s policy against voting by mail or by absentee ballot is that they are widely recognized to be occasions for voter fraud. For example, the 2005 Commission on Federal Election Reform chaired by former President Jimmy Carter and former Secretary of State James Baker III concluded: ‘Absentee ballots remain the largest source of potential voter fraud,’ and “vote by mail ... increases the risk of fraud.”

46. First, not all Wisconsin cities adopted and received conditional grant moneys to administer their respective 2020 general election.

47. Second, those cities that did adopt and receive conditional grant moneys from CTCL, that is the Wisconsin Five, imposed conditions on the administration of elections from a private corporate entity when other cities had no such conditions. Hence, with the added private conditions on Racine's election process, the Racine Complainants were within a jurisdictional boundary that affected them as a demographic group.

48. Similarly, by the Wisconsin Five cities contracting with CTCL and allied private corporations, the Wisconsin Five cities chose to favor the Wisconsin Five's demographic groups of urban voters over all other voters in the State of Wisconsin. By these actions, the "Wisconsin Five" cities favored its urban demographic group over other non-urban Wisconsin voters in federal elections, putting the integrity of the election process in jeopardy—and violating Complainants' rights to lawful and equal elections.

49. Whitney May, Director of Government Services at CTCL, wrote to Racine City Clerk Tara Coolidge and representatives of the other Wisconsin Five cities on August 18, 2020, stating, "You are the famous WI-5...excited to see November be an even bigger success for you and your teams." (139-141).

50. Upon information and belief, on about May 28, 2020, the Council approved the CTCL conditional grant in the amount of \$100,000 to recruit the other Wisconsin Five cities and to prepare the joint Wisconsin Safe Voting Plan 2020 submitted to Center for Tech and Civic Life on June 15, 2020. (393-394)

51. Upon information and belief, on about June 15 , 2020, the Council approved the Wisconsin Safe Voting Plan. (395-415)

52. Upon information and belief, on about August 31, 2020, the Council approved the Wisconsin Safe Voting Plan and adopted the CTCL conditional grant in the amount of \$657,000. (419-420)

53. Upon information and belief, the CTCL conditions in the August 31, 2020 CTCL grant agreed to by Racine included:

- “The grant funds must be used exclusively for the public purpose of planning and operationalizing safe and secure election administration in the City of Racine in accordance with the Wisconsin Safe Voting Plan 2020.” (419)
- Each city or county receiving the funds was required to report back to CTCL by January 31, 2021 regarding the moneys used to conduct federal elections; (420)
- “The City of Racine shall not reduce or otherwise modify planned municipal spending on 2020 elections, including the budget of the City Clerk of Racine (‘the Clerk’) or fail to appropriate or provide previously budgeted funds to the Clerk for the term of this grant. Any amount reduced or not provided in contravention of this paragraph shall be repaid to CTCL up to the total amount of this grant.” (420)
- The City of Racine “shall not use any part of this grant to give a grant to another organization unless CTCL agrees to the specific sub-recipient in advance, in writing.” (419)
- “CTCL may discontinue, modify, withhold part of, or ask for the return of all or part of the grant funds if it determines, in its sole judgement, that (a) any of the above conditions have not been met or (b) it must do so to comply with applicable laws or regulations.” (420)

54. Upon information and belief, despite the stated purpose of helping to assist with a COVID-19 safe election, CTCL’s early communications with the Wisconsin cities

such as Green Bay focused on other, apparently parallel purposes referencing other “resources” to help with: “outgoing and return absentee envelopes,” a “Communications Toolkit” from National Vote at Home Institute, and identifying “voters of color” and “determin[ing] voter sentiment in regards to vote by mail.” ((017-018, 037)

55. Upon information and belief, even though the stated purpose of the CTCL grant was only for the “Safe Voting Plan” and “for no other purpose,” CTCL, when working with the Wisconsin Five, had other conditions that had nothing to do with COVID prevention, such as:

- Employing “voter navigators” to help voters “complete their ballots”; (030-031)
- The “voter navigators” would later be “trained and utilized as election inspectors”; (031)
- ”Utilize paid social media” and “print and radio advertising” to direct voters “to request and complete absentee ballots”; (030)
- “enter new voter registrations and assist with all election certification tasks”; (030)
- “reach voters and potential voters through a multi-prong strategy utilizing ‘every door direct mail,’ targeted mail, geo-fencing, billboards radio, television, and streaming-service PSAs, digital advertising, and automated calls and texts,” and direct mail to “eligible but not registered voters”; (032)
- Assist new voters to “obtain required documents” to get valid state ID needed for voting, targeting African immigrants, LatinX residents, and African Americans; (032) and
- “facilitate Election day Registrations and verification of photo ID.” (032)

56. Upon information and belief, based on CTCL’s agenda, most of the action items had nothing to do with bringing about safe, COVID-19 free voting.

57. Upon information and belief, rather than working toward a COVID-19 safe election, the “projects” that CTCL proposed to the Wisconsin Five were to get the urban vote out. For example, in Green Bay:

- a. Adding satellite locations to “streamline onboarding process for new EIPAV [early in person absentee voting] staff [to be conducted by CTCL’s partner [The (Elections Group)”];
- b. Adding drop boxes;
- c. Printing materials for mail ballots;
- d. Targeting communities with election information through National Vote at Home Institute’s “communication toolkit” to “support outreach around absentee voting” and to “share research insights about how to engage people who might not trust the vote by mail process...”; and
- e. Explaining this “targeting” of communications, Celestine Jeffreys wrote to Whitney May of CTCL on August 27, 2020 that “There are probably 5 organizations that are focused on working with disadvantaged populations and/or with voters directly.” (034, 042)

58. Upon information and belief, Racine was offered by the CTCL the same projects to engage in and did.

59. Upon information and belief, CTCL’s “partners” introduced to the Wisconsin Five included other private entities. For example, in Green Bay, the following CTCL partners were introduced:

- The National Vote At Home Institute (“VoteAtHome” or “NVAHI”) who was represented as a “technical assistance partner” who could consult about among other things, “support outreach around absentee voting,” voting machines and “curing absentee ballots,” and to even take that duty (curing absentee ballots) off of the City of Racine’s hands. (036-049; 051-067) The NVAHI also offered advice and guidance on accepting ballots and streaming central count during election night and on the day of the count. (068-075)
- The Elections Group and Ryan Chew were represented to be able to provide “technical assistance partners to support your office” and “will be connecting with you in the coming days regarding drop

boxes” and technical assistance to “support your office,” and worked on “voter outreach.” (076-078, 205, 079-081) Elections Group Guide to Ballot Boxes. (082-0121)

- Ideas42 was represented by CTCL as using “behavioral science insights” to help with communications. (392)
- Power the Polls was represented by CTCL to help recruit poll workers (122) and discuss ballot curing. (123-124)
- The Mikva Challenge was recommended to recruit high school age poll workers (125-126, 404) and then to have the poll workers to “serve as ballot couriers,” and for “ballot drop-off/voter registrations.” (125-127)
- US Digital Response was suggested to help with and then take over “absentee ballot curing,” and to “help streamline the hiring, onboarding, and management” of Racine’s poll workers. (128-136)
- Center for Civic Design to design absentee ballots and the absentee voting instructions, including working directly with the Commission to develop a “new envelope design” and to create “an advertising/targeting campaign.” (137-0155; 190-0201)
- Eric Ming, the Communications Director for CSME, to serve as a “communications consultant to review your [City of Racine] advertising plan for November.” (156-157)
- The Brennan Center which focuses on “election integrity” including “post-election audits and cybersecurity.” (158-160)
- HVS Productions to add “voter navigator” FAQs and Election Countdown Copy for the city of Racine. (161-166)
- Modern Selections to address Spanish language. (167-169)

60. Upon information and belief, Racine was offered by the CTCL the same projects to engage in and did.

61. Upon information and belief, CTCL’s private corporate “partners” assumed aspects of administration of Wisconsin Five’s election processes. For example, in Green

Bay, the private corporations and their employees engaged in the following aspects of election administration.

- a. Vote at Home volunteered to take curing of ballots off of a municipality's plate; (179-181);
- b. Offered to "lend a hand" to Central Count stations; (182) Elections Group offer; (183)
- c. Offered to connect a municipality to "partners like Power the Polls" to recruit poll workers; to partner with CTCL to send out e-mails to recruit poll workers; (184)
- d. Advised the City as to using DS200 voting machines; (185-188)
- e. Provided a "voter navigator" job description; (189)
- f. Advised a municipality regarding moving the "Central Count" from City Hall to a different location, which was wired to provide election results directly to private corporate employees; (270)
- g. The Center for Civic Design offered a municipality to design the absentee voting instructions and the absentee envelopes; (190-203)
- h. The Elections Group issued a Guide to Ballot Drop Boxes, a report on Planning Drop Boxes, Voter Outreach, and Communication; (204-238)
- i. Provided advice about procedures for challenging an elector's ballot; (239-243) and
- j. Conservation Voices and curing. (244-247)

62. Upon information and belief, Racine was offered by the CTCL the same projects to engage in and did.

63. Upon information and belief, Racine purchased with CTCL funds a "mobile voting precinct" which is legally unauthorized.

64. Upon information and belief, Racine officials began reporting to CTCL of the City's efforts regarding:

- a. Voter outreach/education;
- b. Drop boxes;
- c. Poll books;
- d. Community groups; and
- e. Badger books

(261-264)

65. WEC Administrator Meagan Wolfe, regarding the Wisconsin Five's conduct alleged here, has supported the Wisconsin Five cities' claimed prerogative to adopt private corporate conditions on federal elections without approval by Congress, the state legislature and the Commission.⁵ She most recently stated this legal position on March 31, 2021 before the General Assembly's Campaigns and Elections Committee.⁶

66. The Complainants believe the legal position of WEC Administrator Meagan Wolfe and the rest of the Respondents is incorrect. Only Congress and the state legislature have legal authority to place conditions on federal elections in Wisconsin and to approve private corporations and their employees to engage in federal election administration.

Claim

The Respondents Violated and Will Continue to Violate State Law and the Elections and Electors Clauses

67. The Wisconsin State Legislature under Wisconsin Statutes § 5.05(1) delegated general authority to the Commission for the responsibility of administration of Wisconsin elections.

68. The Wisconsin State Legislature delegates federal election authority to municipal clerks to implement Wisconsin election laws within the respective clerk's municipality. Wis. Stat. § 7.15(1).

69. In general elections held in Racine, the election authority of Congress, the Wisconsin state legislature, the Commission and Racine City Clerk was and will continue to

⁵ Wisconsin Assembly Committee on Campaigns and Elections, "Informational Hearing on General Election Review." Meagan Wolfe. Mar. 31, 2021.

<https://wiseye.org/2021/03/31/assembly-committee-on-campaigns-and-elections-14/> accessed Apr. 6, 2021.

⁶ *Id.*

be illegally and unconstitutionally diverted by the Respondents to entities and persons including Racine's Common Council, Mayor and private corporations and their employees.

70. Without Commission intervention, Racine's illegal and unconstitutional diversion of election authority will continue.

71. Notably, on December 24, 2020, the U.S. Court of Appeals for the Seventh Circuit, in rejecting the Trump campaign's Electors Clause arguments in a Wisconsin case, suggested that the Electors Clause may apply when Wisconsin public officials usurp federal election administrative powers contrary to state law:

The Wisconsin Legislature expressly assigned to the Commission "the responsibility for the administration of ... laws relating to elections," WIS. STAT. § 5.05(1), just as Florida's Legislature had delegated a similar responsibility to its Secretary of State. See *Bush*, 531 U.S. at 116, 121 S.Ct. 525 (Rehnquist, C.J., concurring). Florida's legislative scheme included this "statutorily provided apportionment of responsibility," *id.* at 114, 121 S.Ct. 525, and three Justices found a departure from that scheme when the Florida Supreme Court rejected the Secretary's interpretation of state law. See *id.* at 119, 123, 121 S.Ct. 525. And it was the Minnesota Secretary of State's lack of a similar responsibility that prompted two judges of the Eighth Circuit to conclude that he likely violated the Electors Clause by adding a week to the deadline for receipt of absentee ballots. See *Carson*, 978 F.3d at 1060.

Trump v. Wisconsin Elections Commission, 983 F.3d 919, 927 (7th Cir. 2020). To be sure, in that case, the Trump campaign's 2020 Electors Clause claims regarding "indefinitely confined" voters, endorsing the use of absentee ballot drop boxes, and best practices for correcting a witness's address on an absentee ballot certificate were dismissed by the federal courts.

72. The claims in this matter relating to the City of Racine are distinguishable from those facts in the *Trump* case because these legal claims relate to the Commission's and Racine's diversion of the election law authority of Congress, the Wisconsin State Legislature,

the Commission, and the Racine City Clerk. In this way, the complainants' Elections Clause and Electors Clause claims are similar to the claim considered by the three Supreme Court justices finding a "departure from that scheme" in the Florida case and the claim considered by the two Eighth Circuit judges to be a "likely" violation of the Electors Clause in the Minnesota case. *Wisconsin Elections Commission*, 983 F.3d at 927.

73. The Respondents' past and continuing diversion of election authority violated and continues to violate state and federal law.

Prayer for relief

WHEREFORE, Complainants respectfully request the Commission

- To investigate the circumstances and factual allegations asserted in this Complaint regarding the legality of Racine's acts and actions juxtaposed against state and federal election laws to ascertain whether election laws were violated.
- The investigation should employ all of the Commission's authority by compelling document production, depositions, and testimony of the Respondents, Racine elected officials, Racine election officials, Racine employees, Tiana Epps-Johnson and her employer Center for Tech and Civic Life, Michael Spitzer-Rubenstein and his employer National Vote at Home Institute, Ryan Chew and his employer The Elections Group, Ideas42, Power the Polls, Mikva Challenge, US Digital Response, Center for Civic Design, Eric Ming and his employer CSME, Brennan Center, HVS Productions, and Modern Selections and others involved.

- The Commission should prohibit Respondent Meagan Wolf from any investigatory role because of a conflict of interest due to her being a Respondent.
- The Commission issue an order requiring the Administrator, City of Racine and its City Clerk to conform their conduct to Wisconsin Statutes and the Election and Electors Clauses, restrain themselves from taking any action inconsistent with Wisconsin Statutes and the Election and Electors Clauses and require them to correct their actions and decisions inconsistent with Wisconsin Statutes and the Election and Electors Clauses—including prohibiting the placement of private corporate conditions on state and federal elections and the involvement of private corporation and their employees in election administration.
- The Commission should issue an order declaring that Racine’s private conditions on federal elections and engagement of private corporations and their employees in election administration violated state law and federal law.
- The Commission should also grant any other relief it deems proper, necessary, or just, consistent with the law and under the circumstances of this case.

The requested relief would include, but is not limited to:

- That the Commission reiterate that the Administrator may not render a decision without the approval of the Commission related to the legality of any agreement between private corporate entities and municipalities related to imposing private corporate conditions on its elections or related to private

corporations and their employees being engaged in the administration of election laws;

- That the Commission consider any further prosecutorial investigation be directed to the proper local or state authorities; and,
- Finally, if the Commission determines that election laws were violated or that the law is unclear to provide the Commission itself with the ability to determine the legalities of private corporate conditions directly or indirectly affecting the election process and administration, the Commission should make recommendations to the State Legislature for changes to state election laws to ensure the future integrity of the election process.

Dated: 4/21, 2021



Erick G. Kaardal, No. 1035141
Mohrman, Kaardal & Erickson, P.A.
Special Counsel for Thomas More Society
150 South Fifth Street, Suite 3100
Minneapolis, MN 55402
Telephone: (612) 341-1074
Facsimile: (612) 341-1076
Email: kaardal@mklaw.com
Email: erickson@mklaw.com
Attorneys for the Complainants

Martin Prujansky

VERIFICATION

I, _____, being first duly sworn upon oath, state that I personally read the above verified complaint, and that the above allegations are true and correct based on my personal knowledge and, as to those stated on information and belief, I believe them to be true.

Dated: 4/19, 2021

Martin Prujansky

STATE OF WISCONSIN)
)ss.
COUNTY OF RACINE)

Signed and sworn before me this 04/19, 2021, by *Martin Prujansky*

(Seal, if any)

Emmanuel Sona
Signature of Notarial Officer



Notary Public
Title (and Rank)

My Commission expires: 09/20/24

VERIFICATION

I, _____, being first duly sworn upon oath, state that I personally read the above verified complaint, and that the above allegations are true and correct based on my personal knowledge and, as to those stated on information and belief, I believe them to be true.

Dated: _____, 2021 _____

STATE OF WISCONSIN)
)ss.
COUNTY OF RACINE)

Signed and sworn before me this _____, 2021, by _____

(Seal, if any)

Signature of Notarial Officer

Title (and Rank)

My Commission expires: _____

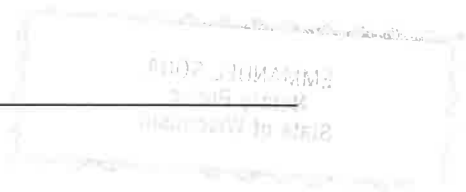

VERIFICATION

I, MARY IMHOFF-PRUJANSKY, being first duly sworn upon oath, state that I personally read the above verified complaint, and that the above allegations are true and correct based on my personal knowledge and, as to those stated on information and belief, I believe them to be true.

Dated: Apr 19, 2021

Mary Imhoff-Prujansky

STATE OF WISCONSIN)
)ss.
COUNTY OF RACINE)

Signed and sworn before me this 04/19, 2021, by Mary Imhoff-Prujansky

(Seal, if any)

Emmanuel Sona
Signature of Notarial Officer



Notary Public
Title (and Rank)

My Commission expires: 09/20/24

VERIFICATION

I, Kenneth Brown being first duly sworn upon oath, state that I personally read the above verified complaint, and that the above allegations are true and correct based on my personal knowledge and, as to those stated on information and belief, I believe them to be true.

Dated: 19 April, 2021

[Signature]

STATE OF WISCONSIN)
)ss.
COUNTY OF RACINE)

Signed and sworn before me this Apr. 19, 2021, by Kenneth Brown

(Seal, if any)

[Signature]
Signature of Notarial Officer

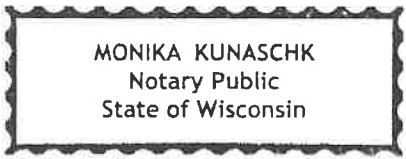

Notary
Title (and Rank)

My Commission expires: 11/20/2024

VERIFICATION

I, Brook Hese, being first duly sworn upon oath, state that I personally read the above verified complaint, and that the above allegations are true and correct based on my personal knowledge and, as to those stated on information and belief, I believe them to be true.

Dated: 4/19, 2021

Brook Hese

STATE OF WISCONSIN)
)ss.
COUNTY OF RACINE)

Signed and sworn before me this April 19, 2021, by Amanda Fischer

(Seal, if any)

Amanda Fischer
Signature of Notarial Officer

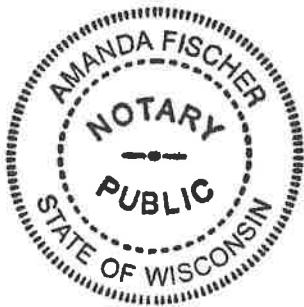

Notary
Title (and Rank)

My Commission expires: 08/09/2024

VERIFICATION

I, Dale Giles, being first duly sworn upon oath, state that I personally read the above verified complaint, and that the above allegations are true and correct based on my personal knowledge and, as to those stated on information and belief, I believe them to be true.

Dated: Apr 19, 2021

Dale Giles

STATE OF WISCONSIN)
)
COUNTY OF RACINE)

Signed and sworn before me this April 19th, 2021, by Debra D. Swenson

(Seal, if any)

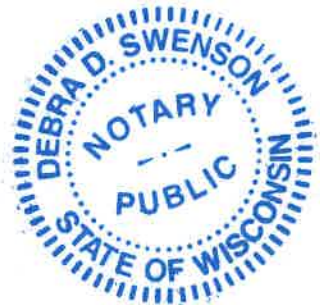

Debra D. Swenson
Signature of Notarial Officer

Title (and Rank)

My Commission expires: 8/19/24

STATE OF WISCONSIN
Before the Wisconsin Election Commission
Case No. _____

Martin Prujansky, Mary Imhof Prujansky, Kenneth Brown, Brooke Hesse, Dale Giles

v.

Administrator Meagan Wolfe, Mayor Cory Mason, City Clerk Tara Coolidge.

AFFIDAVIT OF SERVICE VIA U.S. MAIL

John Grzybek, of the City of Minneapolis, County of Hennepin, State of Minnesota, being affirmed on oath, says that on the 21st day of April, 2021 he served the following:

1. Complaint and Appendix;

on the following parties in this action, by U.S. Mail with a true and correct copy thereof, enclosed in an envelope postage pre-paid, and directed to the following at their last known address:

Administrator Meagan Wolfe
Wisconsin Elections Commission
212 East Washington Avenue, Third Floor
P.O. Box 7984
Madison, Wisconsin 53707-7984

Hon. Cory Mason
Mayor, City of Racine
730 Washington Ave
Racine, WI 53403

Tara Coolidge
City Clerk
730 Washington Ave, Room 103
Racine, WI 53403

John E. Grzybek



Subscribed and affirmed to before me
this 21st day of April, 2021.

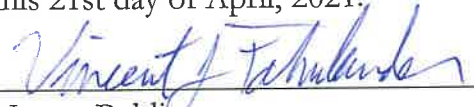

Notary Public

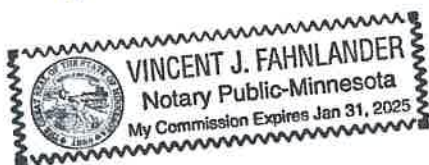

Deanna Debruler

From: Celestine Jeffreys
Sent: Tuesday, September 8, 2020 11:38 PM
To: Kris Teske; Diana Ellenbecker
Subject: FW: [BULK] CTCL COVID-19 Grant Application Portal Now Open

Celestine Jeffreys
Chief of Staff, Mayor's Office
City of Green Bay

From: Center for Tech & Civic Life <help@techandcivicliflife.org>
Sent: Tuesday, September 8, 2020 2:59 PM
To: Celestine Jeffreys <Celestine.Jeffreys@greenbaywi.gov>
Subject: [BULK] CTCL COVID-19 Grant Application Portal Now Open

COVID-19 Grant Application Portal is Open

[View this email in your browser](#)



Thank you for requesting a CTCL COVID-19 grant application. The application portal is now open and you are invited to apply.

The grant application is quick and easy, but you'll need to gather some information before you apply.

- Number of active registered voters in the election office jurisdiction as of September 1, 2020
- Number of full-time staff (or equivalent) on the election team as of September 1, 2020

- Election office 2020 budget as of September 1, 2020
- Election office W-9
- Local government body who needs to approve the grant funding (if any)
- Which government official or government agency the grant agreement should be addressed to

Apply for a COVID-19 Grant

Election offices can use the funds to cover certain 2020 expenses incurred between June 15, 2020 and December 31, 2020. These include the costs associated with the safe administration of the following election responsibilities.

Ensure Safe, Efficient Election Day Administration

- Maintain open in-person polling places on Election Day
- Procure Personal Protective Equipment (PPE) and personal disinfectant to protect election officials and voters from COVID-19
- Support and expand drive-thru voting, including purchase of additional signage, tents, traffic control, walkie-talkies, and safety measures

Expand Voter Education & Outreach Efforts

- Publish reminders for voters to verify and update their address, or other voter registration information, prior to the election
- Educate voters on safe voting policies and procedures

Launch Poll Worker Recruitment, Training & Safety Efforts

Deanna Debruler

From: Celestine Jeffreys
Sent: Saturday, October 3, 2020 2:48 PM
To: Kris Teske
Subject: RE: Supplementary request approved - CTCL COVID-19 Response Grant

Will do, thanks!

Celestine Jeffreys
Chief of Staff, Mayor's Office
City of Green Bay

From: Kris Teske <Kris.Teske@greenbaywi.gov>
Sent: Thursday, October 1, 2020 1:27 PM
To: Celestine Jeffreys <Celestine.Jeffreys@greenbaywi.gov>
Subject: FW: Supplementary request approved - CTCL COVID-19 Response Grant

This is for the Mayor to sign.

Kris Teske, WCMC
Green Bay City Clerk
100 N. Jefferson St., Rm 106
Green Bay, WI 54301
920-448-3014



From: Dennis Granados [<mailto:dennis@techandcivillife.org>]
Sent: Friday, September 18, 2020 5:47 PM
To: Kris Teske <Kris.Teske@greenbaywi.gov>
Subject: Re: Supplementary request approved - CTCL COVID-19 Response Grant

Hi Kris,

As a follow up to Tiana's previous email, I've attached an agreement for review and signature. Please let us know at your earliest convenience if you have any questions or feedback. Otherwise, once the agreement is signed, we can start the disbursement information process. Have a great weekend!

Best,
Dennis

On Tue, Sep 15, 2020 at 9:06 AM Kris Teske <Kris.Teske@greenbaywi.gov> wrote:

Thank you so much!!! ☺

Kris Teske, WCMC
Green Bay City Clerk
100 N. Jefferson St., Rm 106
Green Bay, WI 54301
920-448-3014



From: Tiana Epps-Johnson [mailto:tiana@techandciviclife.org]
Sent: Monday, September 14, 2020 6:02 PM
To: Kris Teske <Kris.Teske@greenbaywi.gov>
Cc: Whitney May <whitney@techandciviclife.org>; Dennis Granados <dennis@techandciviclife.org>
Subject: Supplementary request approved - CTCL COVID-19 Response Grant

Dear Kris,

I'm delighted to share that the Center for Tech and Civic Life has approved a supplementary grant to support Green Bay's Safe Voting Plan at the full amount requested: \$522,200.

Dennis, cc'd, will follow up with a draft grant agreement for your review.

All the best,
Tiana

On Wed, Sep 9, 2020 at 10:48 AM JotForm <noreply@jotform.com> wrote:

 CTCL COVID-19 Response Grant Application

Who is completing this grant application? Kris Teske

What is your title? Green Bay City Clerk

Please select the state and office (or official) you are applying on behalf of. Wisconsin ; Municipal Clerk

What type of jurisdiction are you submitting an application on behalf of? City

City Name Green Bay

I certify that I am permitted to submit this grant request on behalf of the jurisdiction listed above. Yes

Your initials kt

Today's Date 09-09-2020

What number can we reach you at during business hours? (920) 448-3014

Office Mailing Address Street Address: 100 N. Jefferson St., Room 106
City: Green Bay
State / Province: WI
Postal / Zip Code: 54301

What is the email address you use for work? kris.teske@greenbaywi.gov

Share a link to an official government page that contains your bio or lists you in a staff directory <https://greenbaywi.gov/196/Clerk>

How many active registered voters does your jurisdiction have as 53423

of September 1,
2020?

Approximately how
many full time staff
(or equivalent) do
you have on your
team? 5

What is your
jurisdiction's total
budget allocated to
elections this fiscal
year as of September
1, 2020? 329818.00

Please upload a copy
of your current
elections budget [Budget Website-Under Administration.docx](#)

Please upload a W-9
for your jurisdiction [2020-SIGNED-W-9.pdf](#)

For which public
purposes will your
jurisdiction use grant
funds? Polling place rental and cleaning expenses for early
voting or Election Day
Temporary staffing

Will acceptance of
this grant require a
vote of approval by
your local
legislature, council,
or board? No

Title of Individual
Signatory or Name
of Signatory Body Mayor

Name of Individual
Signatory (if
applicable) Eric Genrich

How did you hear
about this grant
opportunity? Center for Tech and Civic Life (CTCL)

You can [edit this submission](#) and [view all your submissions](#) easily.

--

Tiana Epps-Johnson | Founder & Executive Director, Center for Tech and Civic Life
| tiana@techandciviclife.org | she/her

--

Dennis Granados
Executive & Development Assistant
techandciviclife.org

Deanna Debruler

From: Kris Teske
Sent: Wednesday, September 9, 2020 9:58 AM
To: Diana Ellenbecker; Celestine Jeffreys
Cc: Eric Genrich
Subject: RE: CTCL additional grant application
Attachments: FW: [BULK] CTCL COVID-19 Grant Application Portal Now Open

Yes, I received his response. That doesn't answer my question. So I am not supposed to ask for the trucks? Then, I won't ask for the cabinets either. I am getting a lot of conflicting answers.

As I said before if we are getting more electronics don't we want them locked up at the polling locations when they are dropped off the day before? They won't all fit in the bin of the DS200 when we put ballots in there. The guys are lifting equipment now because we don't have lift trucks.

Also, I received an email from you (see attached) yesterday. It doesn't say from Maxwell Love. Is this the one you were referring to? We answered all of these questions already or is this a different grant?

Thank you,

Kris Teske, WCMC
Green Bay City Clerk
100 N. Jefferson St., Rm 106
Green Bay, WI 54301
920-448-3014



From: Celestine Jeffreys [mailto:Celestine.Jeffreys@greenbaywi.gov]
Sent: Wednesday, September 9, 2020 9:27 AM
To: Kris Teske <Kris.Teske@greenbaywi.gov>; Diana Ellenbecker <Diana.Ellenbecker@greenbaywi.gov>
Cc: Eric Genrich <Eric.Genrich@greenbaywi.gov>
Subject: RE: CTCL additional grant application

Good morning, Kris!

I forwarded a link yesterday from Maxwell Love. I'll send it again.

I explained the truck and the cabinets to the Mayor. He shared his opinion with you.

Let me know if there's something else I can clarify.

Celestine Jeffreys
Chief of Staff, Mayor's Office
City of Green Bay

From: Kris Teske <Kris.Teske@greenbaywi.gov>

Sent: Wednesday, September 9, 2020 9:21 AM

To: Celestine Jeffreys <Celestine.Jeffreys@greenbaywi.gov>; Diana Ellenbecker <Diana.Ellenbecker@greenbaywi.gov>

Subject: RE: CTCL additional grant application

Good Morning,

Am I supposed to request these from the grant team? Can I have the form and who to send it to?

The mayor said he didn't agree with the trucks but to ask for anything. Am I still supposed to ask for them? Was it explained to him we can't get the cabinets if we don't have the trucks?

Thanks,

Kris Teske, WCMC
Green Bay City Clerk
100 N. Jefferson St., Rm 106
Green Bay, WI 54301
920-448-3014



From: Celestine Jeffreys [<mailto:Celestine.Jeffreys@greenbaywi.gov>]

Sent: Tuesday, September 8, 2020 9:41 AM

To: Diana Ellenbecker <Diana.Ellenbecker@greenbaywi.gov>; Eric Genrich <Eric.Genrich@greenbaywi.gov>

Cc: Kris Teske <Kris.Teske@greenbaywi.gov>

Subject: RE: CTCL additional grant application

Great, thanks!!

Celestine Jeffreys
Chief of Staff, Mayor's Office
City of Green Bay

From: Diana Ellenbecker <Diana.Ellenbecker@greenbaywi.gov>

Sent: Friday, September 4, 2020 1:30 PM

To: Celestine Jeffreys <Celestine.Jeffreys@greenbaywi.gov>; Eric Genrich <Eric.Genrich@greenbaywi.gov>

Cc: Kris Teske <Kris.Teske@greenbaywi.gov>

Subject: RE: CTCL additional grant application

Thanks for the feedback. Yes, more money to employee additional staff is another option.

Kris, please start the grant application.

Thank you,
Diana

From: Celestine Jeffreys [<mailto:Celestine.Jeffreys@greenbaywi.gov>]

Sent: Friday, September 4, 2020 11:56 AM

To: Diana Ellenbecker <Diana.Ellenbecker@greenbaywi.gov>; Eric Genrich <Eric.Genrich@greenbaywi.gov>
Cc: Kris Teske <Kris.Teske@greenbaywi.gov>
Subject: RE: CTCL additional grant application

I would ask for an even \$500K. That way, we should have a substantial amount of funds to employ people; that's very important.



Celestine Jeffreys

Chief of Staff
Office of the Mayor
920.448.3006

From: Diana Ellenbecker <Diana.Ellenbecker@greenbaywi.gov>
Sent: Friday, September 04, 2020 11:50 AM
To: Eric Genrich <Eric.Genrich@greenbaywi.gov>
Cc: Celestine Jeffreys <Celestine.Jeffreys@greenbaywi.gov>; Kris Teske <Kris.Teske@greenbaywi.gov>
Subject: CTCL additional grant application

Hi Mayor,
Kris pulled together a list of additional equipment that we would like to request from CTCL. Details below.

Celestine requested need \$20,000 (for local groups) and another \$15,000 for absentee ballot collection and events. I think this money is not allocated in the current budget. It's a modest amount.

In total could request an additional:

Supplies	\$150K
Computers	\$216K
Election trucks	\$80K
Celestine	\$35K
Additional	\$481K

I know Kris has the application, but what would you be comfortable and support to request as an additional grant request?

Thank you,
Diana

From: Kris Teske
Sent: Friday, September 4, 2020 7:12 AM
To: Diana Ellenbecker <Diana.Ellenbecker@greenbaywi.gov>
Subject: List

Good Morning,

Here is the list:

Envelope openers (3)	\$13,000
Table top signs (100)	\$3,000
Hand carts (4)	\$1,000
Voting booths (50)	\$10,000
Voting supplies carrier (46)	\$9,200
EZ carts (46)	<u>\$115,000</u>

Additional supplies total \$151,200

Laptops and Printers: \$216,000 (this would replace the BadgerBooks) because BadgerBooks are not available for November election.

2 Lift/Strapping Trucks (This would probably entail purchasing 2 cube/delivery trucks and adding the lifts to them – I haven't received a response back from Steve who was checking into it).

Kris Teske, WCMC
 Green Bay City Clerk
 100 N. Jefferson St., Rm 106
 Green Bay, WI 54301
 920-448-3014



Deanna Debruler

From: Diana Ellenbecker
Sent: Thursday, September 10, 2020 11:18 AM
To: Kris Teske
Subject: RE: CTCL COVID-19 Response Grants/Next Steps

Great job!

Thank you,
Diana

From: Kris Teske
Sent: Thursday, September 10, 2020 9:05 AM
To: Nathan Smith <NSmith@civitaspublicaffairs.com>
Cc: Diana Ellenbecker <Diana.Ellenbecker@greenbaywi.gov>; Eric Genrich <Eric.Genrich@greenbaywi.gov>; Celestine Jeffreys <Celestine.Jeffreys@greenbaywi.gov>
Subject: RE: CTCL COVID-19 Response Grants/Next Steps

Hi Nathan,

I have attached the City of Green Bay Safe Voting Plan for our additional requests.

Thank you so much! Everything the grant is allowing us to purchase will make a huge difference to the Clerk's Office.

Let me know if you need anything else or more of an explanation.

Have a great day!

Kris Teske, WCMC
Green Bay City Clerk
100 N. Jefferson St., Rm 106
Green Bay, WI 54301
920-448-3014



From: Nathan Smith [<mailto:NSmith@civitaspublicaffairs.com>]
Sent: Wednesday, September 9, 2020 4:10 PM
To: Kris Teske <Kris.Teske@greenbaywi.gov>
Subject: CTCL COVID-19 Response Grants/Next Steps
Importance: High

Hi Kris,

Thanks for submitting an application for additional funds for Green Bay through the CTCL COVID-19 Response Grants program. I'm working with CTCL on the project and wanted to follow up.

Because Green Bay was one of the early recipients of funds under this program, we'll be able to expedite additional funds to get you the resources you need. Please complete and return the attached form to request additional funds and specify what the additional funds will be used for. You can send the form back to me once completed.

Thanks very much, and don't hesitate to let me know if you have any questions.

Best,
Nathan

--

Nathan Smith, Senior Associate

Civitas Public Affairs Group

e> nsmith@civitaspublicaffairs.com

c> 202.412.2072

409 7th Street NW, Suite 350, Washington, DC 20004

Deanna Debruler

From: Celestine Jeffreys
Sent: Saturday, July 11, 2020 7:24 AM
To: 'Selkowe, Vicky'; Tiana Epps-Johnson
Subject: RE: Center for Tech & Civic Life Next Steps/Green Bay

Follow Up Flag: Follow up
Flag Status: Completed

Tiana,

I am pleased to meet you and look forward to our conversation. I am the contact person for receiving the draft agreement and getting things started.

My email is Celestine.Jeffreys@greenbaywi.gov. I work half in the office and half at home. The best way to reach me is via email. My desk number is 920-448-3006, I do receive those messages promptly.

Thank you!

Celestine Jeffreys
Chief of Staff, Mayor's Office
City of Green Bay

From: Selkowe, Vicky [mailto:Vicky.Selkowe@cityofracine.org]
Sent: Friday, July 10, 2020 2:48 PM
To: Celestine Jeffreys <Celestine.Jeffreys@greenbaywi.gov>; Tiana Epps-Johnson <tiana@techandciviclife.org>
Subject: Center for Tech & Civic Life Next Steps/Green Bay

Good afternoon Celestine,

I'm delighted to be able to e-connect you to Tiana Epps-Johnson, the Founder & Executive Director of the Center for Tech & Civic Life. Tiana, Celestine is Mayor Eric Genrich's Chief of Staff.

Celestine, Tiana will be sending you a draft grant agreement for your review and approval on Monday. She'll also then be reaching out to schedule individual kick-off calls with each City to begin this work. In addition to the generous funding of our Wisconsin Safe Voting Plan, Tiana and her team have arranged for extensive expert technical assistance from fantastic and knowledgeable partners across the country, to help each City implement our parts of the Plan. Your kick-off call with Tiana will give you a chance to get to know her and the Center for Tech & Civic Life better, understand the resources she's bringing to each of our Cities to successfully and quickly implement the components of our Plan, and answer your questions.

Please let Tiana know who will be the primary contact person for Green Bay's involvement in this effort moving forward so she can follow up directly with that individual about the grant agreement and kick-off planning.

Have a great weekend,

Vicky

Vicky Selkove
Manager, Strategic Initiatives & Community Partnerships
Office of Mayor Cory Mason
City of Racine
Direct: 262-636-9286
Cell: 262-598-6580
vicky.selkove@cityofracine.org



Deanna Debruler

From: Celestine Jeffreys
Sent: Monday, July 13, 2020 11:17 PM
To: 'Tiana Epps-Johnson'
Subject: RE: Center for Tech & Civic Life Next Steps/Green Bay
Attachments: 2020-07-13 Email to Tiana Epps-Johnson.docx

Follow Up Flag: Follow up
Flag Status: Completed

Tiana,

Thank you so much! Your answers are attached. I need to settle who else will be on our team, probably three or four others. I'll provide that info to you in an updated doc by Thursday afternoon.

Celestine Jeffreys
Chief of Staff, Mayor's Office
City of Green Bay

From: Tiana Epps-Johnson [mailto:tiana@techandcivicliflife.org]
Sent: Monday, July 13, 2020 6:31 PM
To: Celestine Jeffreys <Celestine.Jeffreys@greenbaywi.gov>
Cc: Selkowe, Vicky <Vicky.Selkowe@cityofracine.org>
Subject: Re: Center for Tech & Civic Life Next Steps/Green Bay

Hi Celestine,

So good to meet you. I'm really looking forward to working with you in the coming months! As Vicky shared, I'm reaching out to accomplish a few things:

- Share the WI Safe Voting Plan grant agreement for your review (attached)
- Collect point of contact information
- Schedule a kick-off meeting to take place next week

Grant Agreement

A draft grant agreement is attached for your review.

Actions needed:

1. Please review the agreement. Are there any requested revisions?
2. Are there any additional approvals required before you're able to accept the grant funds? If so, what are those steps? And what is the anticipated approval timeline?

Point of Contact Information

We want to be sure we direct our communications to the folks on your end best suited to respond.

Actions needed:

1. Please share the following:
 - a. Primary point of contact (Name, Email, Phone)
 - b. Clerk's office contact (Name, Email, Phone)
 - c. Mayor's office contact (Name, Email, Phone)

July 24, 2020

City of Green Bay

Dear Mayor Genrich,

I am pleased to inform you that the Center for Tech and Civic Life ("CTCL") has decided to award a grant to support the work of the City of Green Bay.

The following is a description of the grant:

AMOUNT OF GRANT: One million, ninety-three thousand, four hundred US dollars (USD \$ 1,093,400.00).

PURPOSE: The grant funds must be used exclusively for the public purpose of planning and operationalizing safe and secure election administration in the City of Green Bay in accordance with the Wisconsin Safe Voting Plan 2020 ("Appendix").

Before we transmit these funds, we ask that you sign this agreement promising to use the grant funds in compliance with United States tax laws. Specifically, by signing this letter you agree to the following:

1. The City of Green Bay is a U.S., state, or local government unit or political subdivision in the meaning of 26 USC 170(c)(1).

2. This grant shall be used only for the public purpose described above, and for no other purposes.
3. The City of Green Bay shall not use any part of this grant to give a grant to another organization unless CTCL agrees to the specific sub-recipient in advance, in writing.
4. The City of Green Bay has produced a plan for safe and secure election administration in 2020, including an assessment of election administration needs, budget estimates for such assessment, and an assessment of the impact of the plan on voters. This plan is attached to this agreement as an Appendix. The City shall expend the amount of this grant for purposes contained in this plan by December 31, 2020.
5. This grant is intended to support and shall be used solely to fund the activities and purposes described in the plan produced pursuant to paragraph 4.
6. The City of Green Bay shall produce a report documenting how this grant has been expended in support of the Appendix. This report shall be provided to CTCL by January 31, 2021.
7. The City of Green Bay shall not reduce or otherwise modify planned municipal spending on 2020 elections, including the budget of the City Clerk of Green Bay ("the Clerk") or fail to appropriate or provide previously budgeted funds to the Clerk for the term of this grant. Any amount reduced or not provided in contravention of this paragraph shall be repaid to CTCL up to the total amount of this grant.
8. CTCL may discontinue, modify, withhold part of, or ask for the return of all or part of the grant funds if it determines, in its sole judgment, that (a) any of the above conditions have not been met or (b) it must do so to comply with applicable laws or regulations.
9. The grant project period of June 15, 2020 through December 31, 2020 represents the dates between which covered costs may be applied to the grant.

Deanna Debruler

From: Celestine Jeffreys
Sent: Saturday, July 25, 2020 7:55 AM
To: 'Dennis Granados'
Subject: RE: Center for Tech and Civic Life - Revised Grant Agreement, Green Bay

Follow Up Flag: Follow up
Flag Status: Completed

Looks great, thanks Dennis!!

Celestine Jeffreys
Chief of Staff, Mayor's Office
City of Green Bay

From: Dennis Granados [mailto:dennis@techandcivicliflife.org]
Sent: Friday, July 24, 2020 7:29 PM
To: Celestine Jeffreys <Celestine.Jeffreys@greenbaywi.gov>
Subject: Center for Tech and Civic Life - Revised Grant Agreement, Green Bay

Hi Celestine,

Please find attached the revised grant agreement for review and signature. Please note that we made a few edits to clean up language, but this did not change the substance of the agreement, unless an update was requested. If you have any concerns please let me know.

In addition, we also updated Section 7 for clarity to the following (changes highlighted in bold):

"The City of Green Bay shall not reduce **or otherwise modify planned municipal spending on 2020 elections, including** the budget of the City Clerk of Green Bay ("the Clerk") or fail to appropriate or provide previously budgeted funds to the Clerk for the term of this grant. Any amount reduced or not provided in contravention of this paragraph shall be repaid to CTCL up to the total amount of this grant."

I look forward to receiving the signed agreement. Please let me know if you have any questions/concerns. Have a great weekend!

Regards,

Dennis

--

Dennis Granados
Executive & Development Assistant
techandcivicliflife.org



GRANT TRACKING FORM

PART #1: Notification of Grant Funds

(emailto:PamelaMa@greenbaywi.gov)

APPLICANT DEPARTMENT: Clerk's office and Mayor's office **DATE:** 06/15/2020

APPLICANT DEPARTMENT GRANT CONTACT NAME/TITLE: Kris Teske, Clerk/Celestine Jeffreys, Chief of Staff

APPROPRIATE COMMITTEE: Finance Committee, Common Council, Ad Hoc Committee on Elections

NAME OF GRANT/FUNDING SOURCE: Center for Tech and Civic Life (through City of Racine's efforts)

AMOUNT OF GRANT REQUEST: \$1,103,400 **LOCAL MATCH REQUIREMENT:** \$0

SOURCE OF MATCH: General Fund Non-General Fund Not Applicable

TIMEFRAME OF GRANT: 06/30/2020 through 12/31/2020

TYPE OF GRANT REQUEST: Monetary Other (explain under 'purpose of grant')

PURPOSE OF GRANT (summary): From the "Wisconsin Safe Voting Plan," As mayors in Wisconsin's five biggest cities - Milwaukee, Madison, Green Bay, Kenosha, and Racine - we seek to work collaboratively on the two remaining 2020 elections (August 11th and November 3rd) to: safely administer elections to reduce the risk of exposure to coronavirus for our residents as well as our election officials and poll workers; identify best practices; innovate to efficiently and effectively educate our residents about how to exercise their right to vote; be intentional and strategic in reaching our historically disenfranchised residents and communities; and, above all, ensure the right to vote in our dense and diverse communities.

How does the grant meet City/Department needs? The grant will provide funds to purchase equipment that will improve efficiencies in the clerk's office; allocate funds for voter outreach, which often gets left by-the-wayside due to staffing constraints; augment staffing in the clerk's office, especially around the presidential election; and meet the equipment and staffing needs of running elections during a pandemic.

What are the personnel requirements (include both existing and new staff) of the grant? The personnel requirements will be: clerk's office staff; mayor's office staff; Ad Hoc Committee on Elections; several LTE positions, and most likely an internal team to work with the Center for Tech and Civic Life. This team will develop the programs outlined in the grant, identify best practices and successfully execute the Safe Voting Plan.

DEPARTMENT HEAD SIGNATURE: _____

PART #2: Request to Accept Grant Funds

(complete after notification of grant award; emailto:PamelaMa@greenbaywi.gov)

AMOUNT OF GRANT AWARD: \$1,103,400 **CFDA/STATE ID #:** _____

LOCAL MATCH REQUIREMENT: \$0

PART	TO:	DATE:	TO:	DATE:
#1: Request to Apply	Finance Dept		FC - Info/Action	
#2: Request to Accept	Finance Dept		FC - Action	



GRANT TRACKING FORM

Please describe the source of match, if applicable: n/a

Please describe any major changes in proposed grant-funded activities: none proposed

Please describe what the grant money will be spent on: The grant funds will be spent on equipment, program development, program execution, advertising/social media, increased salaries for current staff and LTE positions.

<i>PART</i>	<i>TO:</i>	<i>DATE:</i>	<i>TO:</i>	<i>DATE:</i>
#1: Request to Apply	Finance Dept		FC – Info/Action	
#2: Request to Accept	Finance Dept		FC – Action	

Deanna Debruler

From: Celestine Jeffreys
Sent: Tuesday, July 28, 2020 11:03 AM
To: 'Tiana Epps-Johnson'; 'whitney@techandcivildlife.org'
Subject: Signed agreement
Attachments: 2020-07-24 Green Bay CTCL Grant Agreement Signed.pdf



Celestine Jeffreys

Chief of Staff
Office of the Mayor
920.448.3006

Deanna Debruler

From: Kris Teske
Sent: Tuesday, September 15, 2020 9:07 AM
To: Tiana Epps-Johnson
Cc: Whitney May; Dennis Granados
Subject: RE: Supplementary request approved - CTCL COVID-19 Response Grant

Thank you so much!!! ☺

Kris Teske, WCMC
Green Bay City Clerk
100 N. Jefferson St., Rm 106
Green Bay, WI 54301
920-448-3014



From: Tiana Epps-Johnson [mailto:tiana@techandcivicliflife.org]
Sent: Monday, September 14, 2020 6:02 PM
To: Kris Teske <Kris.Teske@greenbaywi.gov>
Cc: Whitney May <whitney@techandcivicliflife.org>; Dennis Granados <dennis@techandcivicliflife.org>
Subject: Supplementary request approved - CTCL COVID-19 Response Grant

Dear Kris,

I'm delighted to share that the Center for Tech and Civic Life has approved a supplementary grant to support Green Bay's Safe Voting Plan at the full amount requested: \$522,200.

Dennis, cc'd, will follow up with a draft grant agreement for your review.

All the best,
Tiana

On Wed, Sep 9, 2020 at 10:48 AM JotForm <noreply@jotform.com> wrote:

 CTCL COVID-19 Response Grant Application

Who is completing
this grant
application? Kris Teske

What is your title? Green Bay City Clerk

Please select the state and office (or official) you are applying on behalf of.

Wisconsin ; Municipal Clerk

What type of jurisdiction are you submitting an application on behalf of?

City

City Name

Green Bay

I certify that I am permitted to submit this grant request on behalf of the jurisdiction listed above.

Yes

Your initials

kt

Today's Date

09-09-2020

What number can we reach you at during business hours?

(920) 448-3014

Office Mailing Address

Street Address: 100 N. Jefferson St., Room 106
City: Green Bay
State / Province: WI
Postal / Zip Code: 54301

What is the email address you use for work?

kris.teske@greenbaywi.gov

Share a link to an official government page that contains your bio or lists you in a staff directory

<https://greenbaywi.gov/196/Clerk>

How many active registered voters does your jurisdiction have as of September 1, 2020?

53423

Approximately how many full time staff (or equivalent) do

5

you have on your team?

What is your jurisdiction's total budget allocated to elections this fiscal year as of September 1, 2020? 329818.00

Please upload a copy of your current elections budget [Budget Website-Under Administration.docx](#)

Please upload a W-9 for your jurisdiction [2020-SIGNED-W-9.pdf](#)

For which public purposes will your jurisdiction use grant funds? Polling place rental and cleaning expenses for early voting or Election Day
Temporary staffing

Will acceptance of this grant require a vote of approval by your local legislature, council, or board? No

Title of Individual Signatory or Name of Signatory Body Mayor

Name of Individual Signatory (if applicable) Eric Genrich

How did you hear about this grant opportunity? Center for Tech and Civic Life (CTCL)

You can [edit this submission](#) and [view all your submissions](#) easily.

--
Tiana Epps-Johnson | Founder & Executive Director, [Center for Tech and Civic Life](#)
| tiana@techandcivicle.org | she/her

Deanna Debruler

From: JotForm <grants@techandciviclife.org>
Sent: Wednesday, September 9, 2020 10:49 AM
To: Kris Teske
Subject: Thank you! We've received your CTCL COVID-19 Response Grant Application.



CTCL COVID-19 Response Grant Application

Who is completing this grant application? Kris Teske

What is your title? Green Bay City Clerk

What type of jurisdiction are you submitting an application on behalf of? City

City Name Green Bay

I certify that I am permitted to submit this grant request on behalf of the jurisdiction listed above. Yes

Your initials kt

Today's Date 09-09-2020

What number can we reach you at during business hours? (920) 448-3014

Office Mailing Address Street Address: 100 N. Jefferson St., Room 106
City: Green Bay
State / Province: WI
Postal / Zip Code: 54301

What is the email address you use for work? kris.teske@greenbaywi.gov

Share a link to an official government page that contains <https://greenbaywi.gov/196/Clerk>

your bio or lists you in
a staff directory

How many active
registered voters does
your jurisdiction have? 53423

Number 5

What is your
jurisdiction's total
budget allocated to
elections this fiscal
year as of September
1, 2020? 329818.00

[Budget Website-Under Administration.docx](#)

[2020-SIGNED-W-9.pdf](#)

For which public
purposes will your
jurisdiction use grant
funds? Polling place rental and cleaning expenses
for early voting or Election Day
Temporary staffing

Will acceptance of this
grant require a vote of
approval by your local
legislature, council, or
board? No

Title of Signatory or
Name of Signatory
Body Mayor

Name of Signatory (if
an individual) Eric Genrich

How did you hear
about this grant
opportunity? Center for Tech and Civic Life (CTCL)

Deanna Debruler

From: Diana Ellenbecker
Sent: Wednesday, August 19, 2020 3:46 PM
To: Kris Teske
Subject: RE: Absentee instructions template & envelopes from Center for Civic Design: Feedback requested by Friday

Don't know, what other changes did she make? I think the room change is a mistake.

If might be easiest to give her a call to find out.

Thank you,
Diana

From: Kris Teske
Sent: Wednesday, August 19, 2020 12:43 PM
To: Diana Ellenbecker <Diana.Ellenbecker@greenbaywi.gov>
Subject: FW: Absentee instructions template & envelopes from Center for Civic Design: Feedback requested by Friday

Do you know why Celestine is making edits to election information? They even have room 201!

Kris Teske, WCMC
Green Bay City Clerk
100 N. Jefferson St., Rm 106
Green Bay, WI 54301
920-448-3014



From: Celestine Jeffreys [<mailto:Celestine.Jeffreys@greenbaywi.gov>]
Sent: Tuesday, August 18, 2020 3:13 PM
To: Kris Teske <Kris.Teske@greenbaywi.gov>; Kim Wayte <Kim.Wayte@greenbaywi.gov>
Subject: FW: Absentee instructions template & envelopes from Center for Civic Design: Feedback requested by Friday

Did you have changes or suggestions? I do, and here's my edited absentee ballot instructions. I will look at the envelopes and also provide to you before I send it back to them.

Celestine Jeffreys

Chief of Staff
Office of the Mayor
920.448.3006



From: Whitney May [<mailto:whitney@techandcivicliflife.org>]

Sent: Tuesday, August 18, 2020 12:07 PM

To: Michelle Nelson; Coolidge, Tara; Celestine Jeffreys; Witzel-Behl, Maribeth; cwooda@milwaukee.gov; Kris Teske

Cc: Josh Goldman; Asher Kolieboi; Christopher Patten

Subject: Absentee instructions template & envelopes from Center for Civic Design: Feedback requested by Friday

Hello Claire, Celestine, Kris, Tara, Michelle, and Maribeth:

You are the famous WI-5. Congrats on successful administration of last week's state primary! Excited to see November be an even bigger success for you and your teams.

With November in mind, I'm cc'ing the designers from Center for Civic Design, Asher & Christopher. CCD is one of the amazing technical assistance partners available to support the WI-5 (we really do need to get WI-5 tshirts).

Since we've heard interest from you about what other cities are doing, we thought it would be helpful to gather feedback on absentee envelopes and instructions from the WI-5 cohort as a group rather than gathering feedback separately.

- Here are the [absentee instructions](#) designed by CCD
 - It's a template in a Word doc
 - You can edit and customize for your city
 - Christopher and Asher are available to consult on design
 - Christopher and Asher have designed this by combining CCD's best practices and language from Madison's instructions.

- Here are the [absentee envelopes](#) designed by CCD
 - CCD has been working on the design with WEC
 - CCD + Oxide Design are available to consult on design and printing with your printer
 - Consult can look like adjusting the templates, adding your contact and other information, working with your envelope vendors (if needed) as you fit the layouts into your process (including any size or placement adjustments), or just providing any support, advice, or reviews of proofs.

Do you and your teams have capacity to review these materials and provide questions and feedback to CTCL & CCD before the end of the week?

We know you are all working on tight timelines for printing and collating absentee materials. Please let CTCL & CCD know how we can be most helpful moving forward. If it's useful, grant funds are available for cities that want to print new envelopes.

Thank you,
Whitney & Josh from CTCL

--

Whitney May
Director of Government Services
Center for Tech and Civic Life
whitney@techandcivicliflife.org
(919) 799-6173
she/her

Agenda and Roles

- **Introductions (15 mins)**
 - Each person on call
 - Please share your name, location, title, and the role you have in implementing the Wisconsin Safe Voting Plan
- **Technical Assistance Overview (10 mins)**
 - Led by Tiana at CTCL
- **Support Needs (20 mins)**
 - Hearing from Green Bay officials
 - What elements do you feel confident moving forward with implementing?
 - What elements of your City's plan might benefit from support from a technical assistance partner?
- **Questions from Technical Assistance Partners (10 mins)**
 - Open to any technical assistance partner
- **Next Steps (5 mins)**
 - Led by Tiana at CTCL

Green Bay's Plans

City	City action
Green Bay	Green Bay would like to employ bilingual LTE "voter navigators" (\$45,000) to help residents properly upload valid photo ID, complete their ballots, comply with certification requirements, and offer witness signatures. These voter navigators can assist voters prior to the elections and then also be trained and utilized as election inspectors.
Green Bay	Green Bay would like to utilize paid social media and local print and radio advertising to educate and direct voters in how to upload photo ID and how to request and complete absentee ballots (\$2,000).
Green Bay	Green Bay would like to add secure (security cameras \$15,000) ballot drop-boxes (approximately \$900 each) at a minimum of the transit center and two fire stations, but if funding were available would also install secure drop boxes at Green Bay's libraries, police community buildings, and potentially several other sites including major grocery stores, gas stations, University of Wisconsin Green Bay, and Northern Wisconsin Technical College, in addition to the one already in use at City Hall.
Green Bay	Green Bay needs 45 additional staff to process absentee ballot requests before the election, to open and verify envelopes on Election Day, and insert them into the tabulators. After the election, staff are needed to enter new voter registrations and assist with all election certification tasks (\$140,000 for staffing). The City would also like to purchase a ballot opener and ballot folder to expedite processing (\$5,000).

Voter navigator Job Description:

This is a limited term employment position, which is grant-funded. The voter navigator helps guide voters to cast a ballot successfully, and works to overcome obstacles, especially due to the pandemic. The navigator will educate voters about their rights and voting options. A successful voter navigator will quickly learn the details of the voting process. Voter navigators will also train to become poll workers, and will work at the polls on Election Day. Voter navigators will work as a group, with city staff and with existing volunteer organizations to create and conduct community events that increase voter awareness and the number of registered voters.

Voter navigator responsibilities:

- Become certified election inspectors, possibly chief inspectors
- Ensure voters are fully informed about the voting process
- Help voters navigate forms, including registration and absentee-by-mail
- Review forms submitted by voters to ensure they are accurate and complete
- Assist voters, potentially at their front doors, to answer questions about interacting with myvote.wi.gov and witnessing absentee ballot signatures
- Work with the team of voter navigators, city staff and existing volunteer organizations to create voter awareness, information and registration events
- Serve as an essential link between the community and the city (clerk's office)

Voter navigator requirements:

- Associate, Bachelor or working towards Bachelor, preferred
- Spanish-language fluency, preferred
- Successful completion of poll worker training (after hire)
- Successful background check
- Computer skills (Microsoft word, excel, etc)
- Able to lift 25 pounds

Patient Navigator Job Description Template

We are looking for a dedicated Patient Navigator to help guide patients through all the various complexities of the healthcare system. You will be responsible for educating patients about their rights, insurance coverage, and

Green Bay	<p>Green Bay would like to expand and establish at least three EIPAV sites in trusted locations, ideally on the east (potentially UWGB) and west sides (potentially NWTC or an Oneida Nation facility) of the City, as well as at City Hall. The City is planning to offer early voting starting two weeks before each election, with several weekdays available until 6:30pm and Saturdays 10am-4pm. They would like to staff these early voting sites with election inspectors who are bilingual and would like to increase the salary rate for these bilingual election inspectors to assist with recruitment and retention, as well as in recognition of their important role at these sites. The City also will need to print additional ballots, signage, and materials to have available at these early voting sites.</p>
Green Bay	<p>Green Bay would like to reach voters and potential voters through a multi-prong strategy utilizing "every door direct mail," targeted mail, geo-fencing, billboards, radio, television, and streaming-service PSAs, digital advertising, and automated calls and texts (\$100,000 total). Efforts can be done in English, Spanish, Hmong, and Somali, since roughly 11% of households in the Green Bay area speak a language other than English. Ideally, the City would employ limited term communications staff or engage communications consultants (\$50,000) from August through the November election to design these communications and design and launch paid advertising on Facebook, Twitter, and Instagram, also in multiple languages. The City would also like to directly mail to residents who are believed to be eligible but not registered voters, approximately 20,000 residents. It would require considerable staff time to construct that list of residents and directly mail a professionally-designed piece (in multiple languages) to those voters (\$50,000 total for staffing, design, printing, and postage).</p>
Green Bay	<p>To assist new voters, Green Bay would also like resources to help residents obtain required documents (i.e. birth certificates) which are needed to get a valid state ID needed for voting. These grant funds (\$15,000) would be distributed in partnership with key community organizations including churches, educational institutions, and organizations serving African immigrants, LatinX residents, and African Americans.</p>
Green Bay	<p>Green Bay needs to hire a total of 380 workers per election (total \$112,660). The City would like to pay poll workers more than they have previously received, to signify their importance in the process and to acknowledge the extra challenge it represents to serve as an election official during a pandemic. The City would like to increase poll worker salaries by 50% (additional \$56,330). All poll workers will be trained through the Wisconsin Elections Commission website and the City's own training manual (\$6,000).</p>
Green Bay	<p>Green Bay would like to purchase 135 electronic poll books (\$2,100/each for a total of \$283,500) to reduce voter lines, facilitate Election Day Registrations and verification of photo ID. The City would also like a high speed tabulator (\$62,000) to count absentee ballots on Election Day, a ballot opener and ballot folder (\$5,000), and additional staff to process absentee ballots on Election Day (\$5,000). The City also needs masks, gloves, gowns, hair nets, face shields (\$15,000), cough/sneeze guards (\$43,000), and disinfectant supplies (\$3,000).</p>

On Fri, Jul 24, 2020 at 9:06 AM Celestine Jeffreys <Celestine.Jeffreys@greenbaywi.gov> wrote:

Tiana

Tiana Epps-Johnson is inviting you to a scheduled Zoom meeting.

Topic: [Kick-off Meeting] WI Safe Vote Plan - Green Bay

Deanna Debruler

From: Celestine Jeffreys
Sent: Tuesday, August 4, 2020 2:53 PM
To: Diana Ellenbecker; Pamela Manley; Joseph Faulds; Kris Teske; Jill Vandenplas
Subject: Waiting to hear back from CTCL

Hello!

Still waiting to hear back from CTCL on our schemes. The last email, with the various rates and payments, made the most sense to me. We will need election help this year and we've allocated enough funds to accomplish that task.



Celestine Jeffreys

Chief of Staff
Office of the Mayor
920.448.3006

Could we take funds from the Badger book line? That's \$283K. If not, what about from the PPE/cough guards or the ballot folder lines?

There are probably 5 organizations in town that are focused on working with disadvantaged populations and/or with voters directly. I thought roughly \$5K (each) for their efforts (reimbursable expenses, of course). I don't have a sense of what's appropriate, so I haven't thought of a budget. Whitney, what do you recommend?

Thanks!!
Celestine

Ensure Safe and Efficient Election Day Administration		deadline and lead	
Safe and Efficient Election Day Administration--\$426,500			
purchase electronic poll books -- \$283,500 RFP	determine availability	10/15 Clerk (Kris)	
purchase high speed tabulator -- \$62,000 RFP			
purchase ballot opener and folder -- \$5,000 already purchased			
additional staff to process absentee ballots on election day - \$5,000 hire new staff, hire temps to replace staff? how does existing staff reassigned accomplish their own work?	determine need	9/8 Clerk (Kris)	
PPE -- \$15,000 already purchased			
cough guards -- \$43,000 already purchased			
disinfectant supplies -- \$3,000 already purchased			
30,000 black pens -- ???	obtain the pens	10/15 Procure (

From: Whitney May <whitney@techandcivillife.org>
Sent: Wednesday, August 26, 2020 7:16 PM
To: Celestine Jeffreys <Celestine.Jeffreys@greenbaywi.gov>
Cc: Kris Teske <Kris.Teske@greenbaywi.gov>
Subject: Re: FW: Following up on CTCL request

Deanna Debruler

From: Celestine Jeffreys
Sent: Monday, July 27, 2020 10:30 AM
To: 'Tiana Epps-Johnson'
Subject: RE: [Detailed Agenda] Election Grant Team meeting with CTCL (granting agency)

Follow Up Flag: Follow up
Flag Status: Completed

Thanks!!



Celestine Jeffreys

Chief of Staff
Office of the Mayor
920.448.3006

From: Tiana Epps-Johnson [mailto:tiana@techandcivicliflife.org]
Sent: Monday, July 27, 2020 8:47 AM
To: Celestine Jeffreys
Cc: Calvin Winters; Joanne Bungert; Joseph Faulds; Kim Wayte; Kris Teske; Pamela Manley; Shelby Hearley; Stephanie Hummel; Eric Genrich; Diana Ellenbecker
Subject: [Detailed Agenda] Election Grant Team meeting with CTCL (granting agency)

Hi all,

I'm really looking forward to talking with you today and introducing you to some of the Center for Tech and Civic Life's partners who are available to help the City of Green Bay implement your Safe Voting Plan. I'm including meeting information including attendees, agenda, and roles below.

We will ask you each to give a quick introduction (prompts included in the "Agenda and Roles" section below). We also have 20 mins on the agenda dedicated to hearing from you ("Support Needs" below). During this time we'd like to hear from you about the top areas where you think the City of Green would benefit from support as you work to implement the Safe Voting Plan, as well as the things you feel confident you have handled.

Please note we have a network of current and former election administrators and election experts available to provide assistance on communications; scaling up your vote by mail processes; poll worker recruitment and training in a pandemic; applying public health guidelines to polling places; designing election materials to ensure forms, envelopes, and other materials are understood and completed correctly by voters; and more.

If you have any questions please reach out.

Best,
Tiana

Call Details

Deanna Debruler

From: Celestine Jeffreys
Sent: Wednesday, August 12, 2020 2:35 PM
To: Whitney May
Subject: RE: CTCL follow up: Envelope design, comms toolkit, voters of color webinar

Follow Up Flag: Follow up
Flag Status: Completed

We are in the middle of changing over to Microsoft office 365, so I wasn't able to get back into my computer. I'll check out the you tube video.

Celestine Jeffreys
Chief of Staff, Mayor's Office
City of Green Bay

From: Whitney May [mailto:whitney@techandcivicliflife.org]
Sent: Thursday, August 6, 2020 5:24 PM
To: Celestine Jeffreys <Celestine.Jeffreys@greenbaywi.gov>
Subject: Re: CTCL follow up: Envelope design, comms toolkit, voters of color webinar

Hmmmm. In addition to the webinar tomorrow, they are also doing one tonight at 6:30pm. I registered for that one and it gave me this YouTube link: <https://www.youtube.com/watch?v=aTs9O3AFB2w>

On Thu, Aug 6, 2020 at 4:50 PM Celestine Jeffreys <Celestine.Jeffreys@greenbaywi.gov> wrote:

Thanks, Whitney!!

I'm getting those documents for you and I am excited about the webinar tomorrow. I'm having a little difficulty registering, but I'll "reset" my computer and see if that helps.

Celestine Jeffreys
Chief of Staff, Mayor's Office
City of Green Bay

From: Whitney May [mailto:whitney@techandcivicliflife.org]
Sent: Thursday, August 6, 2020 3:54 PM
To: Celestine Jeffreys <Celestine.Jeffreys@greenbaywi.gov>
Subject: CTCL follow up: Envelope design, comms toolkit, voters of color webinar

Hi Celestine,

Great catching up with you today! Here are the resources we discussed.

- Outgoing and return absentee envelopes from Center for Civic Design (CCD). They are already in conversation with WEC to get this approved at the state level. I recognize you may not be able to roll these out for November, but keep them on your radar for 2021.
- Communications Toolkit from National Vote at Home Institute (NVAHI). Includes sample graphics, language, and comms plans. Just plug and play. Also, NVAHI is planning to do a webinar after the primary to dig into the toolkit and answer questions from WI clerks. Date and time TBD, so stay tuned on this front.
- Voters of Color: Communicating Safe Options for November. This is a free webinar tomorrow at 10:30 am Central Time that will go over the results of a national survey of POC voters to determine voter sentiment in regards to vote by mail.

Looking forward to talking again on August 20th, and we'll stay in touch via email between now and then. I'll see what I can find out about legal and comms consultant guidance from CSME.

Good luck with your primary next week!

Best,

Whitney

--

Whitney May

Director of Government Services

Center for Tech and Civic Life

whitney@techandcivicliflife.org

(919) 799-6173

she/her

--

Whitney May

Director of Government Services

Center for Tech and Civic Life
whitney@techandciviclife.org
(919) 799-6173
she/her

Deanna Debruler

From: Whitney May <whitney@techandcivillife.org>
Sent: Thursday, August 6, 2020 7:09 PM
To: Celestine Jeffreys
Subject: Re: CTCL follow up: Envelope design, comms toolkit, voters of color webinar

Follow Up Flag: Follow up
Flag Status: Completed

Screenshot from the webinar below:

Programming Guidance. What to do to encourage POC to vote by mail

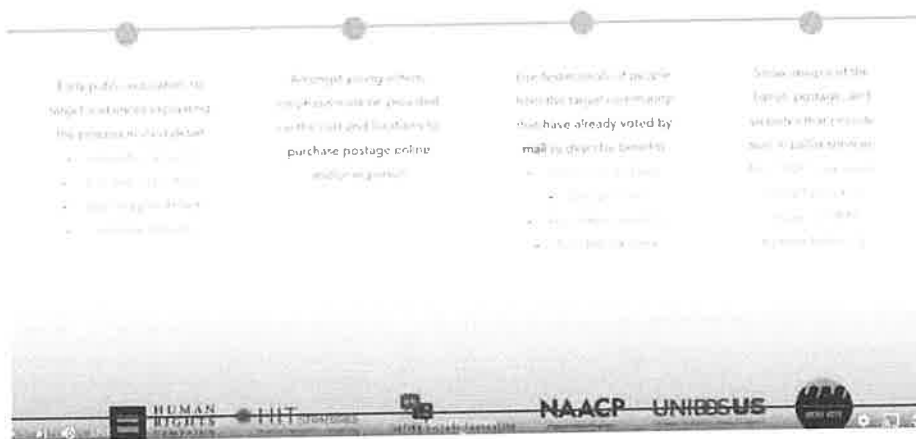

This reminds me about this amazing resource: <https://www.healthyvoting.org/wisconsin/>

It currently has info for Tuesday's primary and will be updated for November. It includes a printable pocket guide that Green Bay can distribute through your office and community orgs.

Pocket guide: <https://www.healthyvoting.org/pdf/wisconsin.pdf>

Printing and folding instructions: <https://www.healthyvoting.org/how-to-print-voting-guides/>

Spanish version will be available in November, too.

On Thu, Aug 6, 2020 at 5:23 PM Whitney May <whitney@techandcivillife.org> wrote:
Hmmm. In addition to the webinar tomorrow, they are also doing one tonight at 6:30pm. I registered for that one and it gave me this YouTube link: <https://www.youtube.com/watch?v=aTs9O3AFB2w>

On Thu, Aug 6, 2020 at 4:50 PM Celestine Jeffreys <Celestine.Jeffreys@greenbaywi.gov> wrote:

Thanks, Whitney!!

I'm getting those documents for you and I am excited about the webinar tomorrow. I'm having a little difficulty registering, but I'll "reset" my computer and see if that helps.

Celestine Jeffreys

Chief of Staff, Mayor's Office

City of Green Bay

From: Whitney May [mailto:whitney@techandcivicliflife.org]
Sent: Thursday, August 6, 2020 3:54 PM
To: Celestine Jeffreys <Celestine.Jeffreys@greenbaywi.gov>
Subject: CTCL follow up: Envelope design, comms toolkit, voters of color webinar

Hi Celestine,

Great catching up with you today! Here are the resources we discussed.

- Outgoing and return absentee envelopes from Center for Civic Design (CCD). They are already in conversation with WEC to get this approved at the state level. I recognize you may not be able to roll these out for November, but keep them on your radar for 2021.
- Communications Toolkit from National Vote at Home Institute (NVAHI). Includes sample graphics, language, and comms plans. Just plug and play. Also, NVAHI is planning to do a webinar after the primary to dig into the toolkit and answer questions from WI clerks. Date and time TBD, so stay tuned on this front.
- Voters of Color: Communicating Safe Options for November. This is a free webinar tomorrow at 10:30 am Central Time that will go over the results of a national survey of POC voters to determine voter sentiment in regards to vote by mail.

Looking forward to talking again on August 20th, and we'll stay in touch via email between now and then. I'll see what I can find out about legal and comms consultant guidance from CSME.

Good luck with your primary next week!

Best,

Whitney

--

Whitney May

Director of Government Services

Center for Tech and Civic Life

whitney@techandcivicliflife.org

(919) 799-6173

she/her

--

Whitney May

Director of Government Services

Center for Tech and Civic Life

whitney@techandcivicliflife.org

(919) 799-6173

she/her

--

Whitney May

Director of Government Services

Center for Tech and Civic Life

whitney@techandcivicliflife.org

(919) 799-6173

she/her

Deanna Debruler

From: Celestine Jeffreys
Sent: Monday, August 17, 2020 6:46 PM
To: Kris Teske
Cc: Whitney May
Subject: FW: CTCL implementation support: Response requested by Tuesday

Kris,

Below was the subject of my conversation with Whitney last week.

We are still in flux about the EIPAV locations; we'll have a conversation about drop boxes this week; they need our materials to help redesign the inserts for the absentee ballots, and they've been working with the WEC for a new envelope design; creating an advertising/targeting campaign—still need to do this. Whitney has connected me with someone, and hopefully we'll talk about advertising/targeting this week.

At our upcoming meeting, I suggest we discuss our onboarding process for poll workers and the materials the clerk's office provides to poll workers. These could use some streamlining and redesign.

Thanks!

Celestine Jeffreys
Chief of Staff, Mayor's Office
City of Green Bay

From: Whitney May [mailto:whitney@techandcivillife.org]
Sent: Friday, July 31, 2020 3:43 PM
To: Celestine Jeffreys <Celestine.Jeffreys@greenbaywi.gov>
Subject: CTCL implementation support: Response requested by Tuesday

Hi Celestine,

Reflecting on your Safe Voting Plan, the kickoff call last week, and your spreadsheet, I wanted to get your feedback about the projects our technical partners should tackle first.

What are the most urgent areas where you'd like support from the partners? Here's what I synthesized as the likely top 3-4:

- **Adding satellite locations** -- review training materials to streamline onboarding process for new EIPAV staff (Elections Group)
- **Adding drop boxes** -- provide tailored guidelines and implementation support, especially around security and optimized driving routes (Elections Group)
- **Printing materials for mail ballots** -- redesign bilingual absentee ballot instruction sheet and letter (Center for Civic Design, who is working with WEC on envelope design)
- **Targeting communities with election information** -- NVAHI is launching a communications toolkit on August 6 to support outreach around absentee voting (National Vote at Home Institute), share research insights about how to engage people who might not trust the vote by mail process (Center for Civic Design)

Let's use our time on Thursday to discuss priorities, partners, and what might work as a standing, every-other-week meeting time.

Thanks, Celestine! Reach out if you have questions. Looking forward to hearing back about your priorities by Tuesday.

Best,
Whitney

--

Whitney May
Director of Government Services
Center for Tech and Civic Life
whitney@techandcivicliflife.org
(919) 799-6173
she/her

Deanna Debruler

From: Kris Teske
Sent: Monday, October 5, 2020 11:49 AM
To: Celestine Jeffreys; Kim Wayte; Eric Genrich; Diana Ellenbecker; Vanessa Chavez
Subject: RE: Meet Next Week? Ballot Curing

Hi,

After Kim and I met with people from the grant team on curing we decided it wouldn't be beneficial to our office and they pretty much agreed that there wouldn't be any time savings. Our main issue was curing requests and they couldn't help us with that. The ballot curing has been going on since we sent out the ballots in September. We really don't have the time to be working on a new process now that we have the ballots.

Thanks,

Kris Teske, WCMC
Green Bay City Clerk
100 N. Jefferson St., Rm 106
Green Bay, WI 54301
920-448-3014



From: Celestine Jeffreys [mailto:Celestine.Jeffreys@greenbaywi.gov]
Sent: Saturday, October 3, 2020 1:49 PM
To: Kris Teske <Kris.Teske@greenbaywi.gov>; Kim Wayte <Kim.Wayte@greenbaywi.gov>; Eric Genrich <Eric.Genrich@greenbaywi.gov>; Diana Ellenbecker <Diana.Ellenbecker@greenbaywi.gov>; Vanessa Chavez <Vanessa.Chavez@greenbaywi.gov>
Subject: FW: Meet Next Week? Ballot Curing

The grant mentors would like to meet with you to discuss, further, the ballot curing process. Please let them know when you're available.

Celestine Jeffreys
Chief of Staff, Mayor's Office
City of Green Bay

From: Michael Spitzer-Rubenstein <michael@voteathome.org>
Sent: Friday, October 2, 2020 5:23 PM
To: Celestine Jeffreys <Celestine.Jeffreys@greenbaywi.gov>
Subject: Meet Next Week? Ballot Curing

Celestine,
Could we meet next week with someone in the clerk's office to go over ballot curing and adding a call operation?

Wednesday (any time after 10 AM) would work best for me. If that doesn't work, can do Tuesday (10-2) or Thursday (before 1 PM).

If you have a letter that goes out with rejected ballots, could you send that? (If not, I can create one).

I'm going to put together a process document, phone script, and job description/simple RFP—could either hire a firm or a few individuals to do the calls.

Thanks and enjoy your weekend,
Michael

--

Michael Spitzer-Rubenstein
State Lead for Wisconsin (Leadership Now Fellow)
National Vote at Home Institute



he/him



Learn more about:

[Election Officials Center](#)

[Mail Ballot FAQs](#)

[Mail Ballot Security](#)

Deanna Debruler

From: Michael Spitzer-Rubenstein <michael@voteathome.org>
Sent: Thursday, October 29, 2020 11:18 AM
To: Kim Wayte; Jaime Fuge; Diana Ellenbecker
Subject: 15 minutes later today?

Hi Kim,
I'm putting together instructions for the Central Count workers, augmenting your guide with the DS450 instructions. There were just a couple points that I wanted to confirm.

Do you have a few minutes this afternoon to go through the process? I'll make myself available any time you are.

Thanks,
Michael

--

Michael Spitzer-Rubenstein
State Lead for Wisconsin (Leadership Now Fellow)
National Vote at Home Institute
(310) 980-2872
he/him



Learn more about:
[Election Officials Center](#)
[Mail Ballot FAQs](#)
[Mail Ballot Security](#)

Deanna Debruler

From: Michael Spitzer-Rubenstein <michael@voteathome.org>
Sent: Tuesday, September 8, 2020 1:18 PM
To: Kris Teske
Cc: Celestine Jeffreys; Shelby Edlebeck; Laura Schley; Stephanie Hummel; Whitney May; Ryan Chew; Haley McKean
Subject: Re: 2020-09-07 Get Ready Vote--Voice.jpg

Celestine and team,
Thanks for getting things going!

I'll get you the AI files so it's easier to edit the graphics and will send a few small suggestions as well.

We're excited to help your work!
Michael

On Mon, Sep 7, 2020 at 3:14 PM Kris Teske <Kris.Teske@greenbaywi.gov> wrote:

Hi,

Here are my changes:

- Photo ID doesn't need the current address when absentee voting.
- To register to vote you don't need photo ID just proof of residence.

Kris Teske, WCMC

Green Bay City Clerk

100 N. Jefferson St., Rm 106

Green Bay, WI 54301

920-448-3014



From: Celestine Jeffreys [mailto:Celestine.Jeffreys@greenbaywi.gov]
Sent: Monday, September 7, 2020 12:17 PM
To: Shelby Hearley <Shelby.Hearley@greenbaywi.gov>; Laura Schley <Laura.Schley@greenbaywi.gov>; Stephanie Hummel <Stephanie.Hummel@greenbaywi.gov>; Kris Teske <Kris.Teske@greenbaywi.gov>; Whitney May <whitney@techandciviclife.org>
Cc: Michael Spitzer-Rubenstein <michael@voteathome.org>; 'Ryan Chew' <ryan@electionsgroup.com>; Haley McKean <haley@electionsgroup.com>
Subject: 2020-09-07 Get Ready Vote--Voice.jpg

Hello!

See the above graphic. I'd like for us to amend this with the following information:

- Use our mood board
- Use the city logo
- Keep the "get ready, vote"
- Maybe use the vote hand graphic (but in the mood board colors)?
- Add "Make a Voting Plan" at the bottom instead of "make your voice heard"

Shelby, can we add to our website a "GreenBayVotes2020" or something like that so that people can google that address and find information directly on our website?

I'd like to post voter resources there, especially to help people make their voting plan.

See the attached document for my ideas to help people make a voting plan. This is something we can promote until we have our public relations firm on-board.

Thoughts, everyone?

Sent from Mail for Windows 10

--

Michael Spitzer-Rubenstein
State Lead for Wisconsin (Leadership Now Fellow)
National Vote at Home Institute
(310) 980-2872
he/him



Deanna Debruler

From: Michael Spitzer-Rubenstein <michael@voteathome.org>
Sent: Tuesday, October 27, 2020 8:10 PM
To: Vanessa Chavez
Cc: Celestine Jeffreys; Diana Ellenbecker; Kim Wayte
Subject: Re: Ballot Receipt and Central Count

Thanks, Vanessa. I'm just nervous about how the WEC interprets the statute because other cities are operating differently.

Michael

On Tue, Oct 27, 2020 at 7:12 PM Vanessa Chavez <Vanessa.Chavez@greenbaywi.gov> wrote:

Hi Michael,

As I noted on the call, I reached out to the WEC with my interpretation of Wis. Stat. 7.52(1)(a), which specifically references receipt by the municipal clerk, not central count. I informed them that we are still looking for additional guidance to ensure there are no unnecessary challenges as a result. They responded that they will review and get us an answer shortly. I have not heard anything.

Vanessa

Vanessa R. Chavez, *City Attorney*

City of Green Bay

(920) 448-3080

Vanessa.Chavez@greenbaywi.gov

LEGAL DISCLAIMER: This message and all attachments may be confidential or protected by privilege. If you are not the intended recipient, you are hereby notified that any disclosure, copying, distribution or use of the information contained in or attached to this message is strictly prohibited. Please notify the sender of the delivery error by replying to this message, and then delete it from your system. Thank you.

From: Michael Spitzer-Rubenstein [mailto:michael@voteathome.org]
Sent: Tuesday, October 27, 2020 6:22 PM
To: Vanessa Chavez <Vanessa.Chavez@greenbaywi.gov>
Subject: Ballot Receipt and Central Count

Hi Vanessa, have you been able to get an answer from the WEC about whether we can receive ballots at City Hall before 8 PM and then move them to Central Count after 8?

I'm very concerned that we're walking into potential issues.

Thanks,

Michael

--

Michael Spitzer-Rubenstein

State Lead for Wisconsin (Leadership Now Fellow)

National Vote at Home Institute

(310) 980-2872

he/him



Learn more about:

[Election Officials Center](#)

[Mail Ballot FAQs](#)

[Mail Ballot Security](#)

--

Michael Spitzer-Rubenstein

State Lead for Wisconsin (Leadership Now Fellow)

National Vote at Home Institute

(310) 980-2872

he/him



Learn more about:

[Election Officials Center](#)

Mail Ballot FAQs
Mail Ballot Security

Deanna Debruler

From: Michael Spitzer-Rubenstein <michael@voteathome.org>
Sent: Sunday, November 1, 2020 11:59 AM
To: Amaad Rivera; Jaime Fuge
Subject: Ballot Transportation

Hi Jaime, are the ballots going to be in trays/boxes within the bin?

I'm at KI now, trying to figure out whether we'll need to move the bins around throughout the day or if we can just stick them along the wall and use trays or something similar to move the ballots between stations.

Michael

--

Michael Spitzer-Rubenstein
State Lead for Wisconsin (Leadership Now Fellow)
National Vote at Home Institute
(310) 980-2872
he/him



Learn more about:

[Election Officials Center](#)

[Mail Ballot FAQs](#)

[Mail Ballot Security](#)

Deanna Debruler

From: Michael Spitzer-Rubenstein <michael@voteathome.org>
Sent: Tuesday, November 3, 2020 9:29 PM
To: Vanessa Chavez
Subject: Re: Be prepared: ballots delayed

I think were probably okay; I don't think anyone challenged the ballots when they came in.

On Tue, Nov 3, 2020 at 9:27 PM Vanessa Chavez <Vanessa.Chavez@greenbaywi.gov> wrote:
Thanks for the heads up.

Sent from my iPhone

On Nov 3, 2020, at 8:27 PM, Michael Spitzer-Rubenstein <michael@voteathome.org> wrote:

In case you didn't hear, someone or several people harassed CSOs and prevented one of the dropbox deliveries from getting to City Hall by 8 PM.

We have the delivery logs to establish that they picked the ballots well before 8. Milwaukee is prepared to rely on the same interpretation we're using about the City Hall dropboxes to say that any ballots in the hands of the clerk's agents before 8 PM count.

Want you to be prepared and feel free to give me a call: 310-980-2872.

--

Michael Spitzer-Rubenstein
State Lead for Wisconsin (Leadership Now Fellow)
National Vote at Home Institute
(310) 980-2872
he/him



Learn more about:
[Election Officials Center](#)
[Mail Ballot FAQs](#)
[Mail Ballot Security](#)

--

Michael Spitzer-Rubenstein
State Lead for Wisconsin (Leadership Now Fellow)
National Vote at Home Institute
(310) 980-2872
he/him



Learn more about:
[Election Officials Center](#)
[Mail Ballot FAQs](#)

Mail Ballot Security

Deanna Debruler

From: Jaime Fuge
Sent: Monday, November 2, 2020 7:34 AM
To: Saralynn Finn
Cc: michael@voteathome.org
Subject: RE: Central Count Ballot Tracking Sheets

This is very helpful.

Thank you!

From: Saralynn Finn [mailto:saralynn@voteathome.org]
Sent: Saturday, October 31, 2020 10:31 PM
To: Michael Spitzer-Rubenstein <michael@voteathome.org>
Cc: Jaime Fuge <Jaime.Fuge@greenbaywi.gov>
Subject: Re: Central Count Ballot Tracking Sheets

Yes, here is the document I made to hand out to central count observers.
I can send you an editable version if you need or try and make any changes you want.
Best,
Saralynn

On Sat, Oct 31, 2020 at 4:35 PM Michael Spitzer-Rubenstein <michael@voteathome.org> wrote:

Saralynn, you've been working on observers. Do you have a good guide for questions they're likely to ask & answers?

Also, Jaime, just to follow up on the call and this email, would you prefer doing a cover sheet like what we created before (travels with the batch of ballots) or a log like what Milwaukee uses (sits at the table)?

Can talk about it tomorrow or even Monday. Will just be a minor tweak of the instructions either way.

Michael

On Sat, Oct 31, 2020 at 4:27 PM Jaime Fuge <Jaime.Fuge@greenbaywi.gov> wrote:

Hi,

I do have a followup question that came to my mind. What are some of the common questions the observers ask. We have not really have observers that have asked many questions prior.

Thank you,

Jaime

From: Michael Spitzer-Rubenstein [mailto:michael@voteathome.org]

Sent: Friday, October 30, 2020 10:24 PM

To: Celestine Jeffreys <Celestine.Jeffreys@greenbaywi.gov>; Jaime Fuge <Jaime.Fuge@greenbaywi.gov>; Amaad Rivera <Amaad.Rivera@greenbaywi.gov>; Kim Wayte <Kim.Wayte@greenbaywi.gov>

Subject: Central Count Ballot Tracking Sheets

Hi all,

Sharing the updated versions of the ballot tracking sheets for Central Count:

1. Courier log for City Hall to KI (adjusting the dropbox log)
2. Processing cover sheet (for tracking a batch of ballots from a single ward into the DS450)
3. Reconstruction cover sheet (for tracking ballots that need remaking in a single batch across many wards)

Since we have the processes nailed down and I understand it all now, I'm going to work on the training manual tomorrow.

See you tomorrow,

Michael

--

Michael Spitzer-Rubenstein

State Lead for Wisconsin (Leadership Now Fellow)

National Vote at Home Institute

(310) 980-2872

he/him



Learn more about:

[Election Officials Center](#)

[Mail Ballot FAQs](#)

Mail Ballot Security

--
Michael Spitzer-Rubenstein

State Lead for Wisconsin (Leadership Now Fellow)

National Vote at Home Institute

(310) 980-2872

he/him



Learn more about:

Election Officials Center

Mail Ballot FAQs

Mail Ballot Security

Deanna Debruler

From: Michael Spitzer-Rubenstein <michael@voteathome.org>
Sent: Friday, October 30, 2020 10:24 PM
To: Celestine Jeffreys; Jaime Fuge; Amaad Rivera; Kim Wayte
Subject: Central Count Ballot Tracking Sheets
Attachments: Delivery Log.docx; Processing Cover Sheet.docx; Reconstruction Cover Sheet.docx

Hi all,
Sharing the updated versions of the ballot tracking sheets for Central Count:

1. Courier log for City Hall to KI (adjusting the dropbox log)
2. Processing cover sheet (for tracking a batch of ballots from a single ward into the DS450)
3. Reconstruction cover sheet (for tracking ballots that need remaking in a single batch across many wards)

Since we have the processes nailed down and I understand it all now, I'm going to work on the training manual tomorrow.

See you tomorrow,
Michael

--

Michael Spitzer-Rubenstein
State Lead for Wisconsin (Leadership Now Fellow)
National Vote at Home Institute
(310) 980-2872
he/him



Learn more about:
[Election Officials Center](#)
[Mail Ballot FAQs](#)
[Mail Ballot Security](#)

Deanna Debruler

From: Michael Spitzer-Rubenstein <michael@voteathome.org>
Sent: Sunday, November 1, 2020 10:52 AM
To: Diana Ellenbecker; Jaime Fuge; Amaad Rivera
Subject: Central Count Staffing Roles
Attachments: KI Diagram with Roles.pdf; Central Count Staff List.xlsx

Hi all,
In advance of meeting tomorrow, I'm attaching two files:

1. A diagram of KI with tables marked.
2. A Central Count Staff List (blank but with all the roles we'll need for shifts 1 and 2). For roles with a partner, I labeled them A and B.

I'm not sure what the count is right now, but here's where I would put extra people:

- 1 extra person for each of the scanners (so 3 total), working on paperwork and ballot flattening
- Extra runners/ballot sorters (depending on how many ballots we get on Election Day, either very busy or very boring), could also trade-off with the person guarding the dropbox
- An extra Reconstruction table (would need to be experienced)
- Check-in table for press/observers and second shift

Michael

--

Michael Spitzer-Rubenstein
State Lead for Wisconsin (Leadership Now Fellow)
National Vote at Home Institute
(310) 980-2872
he/him



Learn more about:

[Election Officials Center](#)

[Mail Ballot FAQs](#)

[Mail Ballot Security](#)

Deanna Debruler

From: Michael Spitzer-Rubenstein <michael@voteathome.org>
Sent: Wednesday, October 28, 2020 3:41 PM
To: Vanessa Chavez
Subject: Re: Election Day Receipt of Ballots

I'm at 310-980-2872

On Wed, Oct 28, 2020 at 3:40 PM Vanessa Chavez <Vanessa.Chavez@greenbaywi.gov> wrote:

I am working remotely today, but I am free until about 4:15. What number should I call you at?

Vanessa R. Chavez, *City Attorney*

City of Green Bay

(920) 448-3080

Vanessa.Chavez@greenbaywi.gov

LEGAL DISCLAIMER: This message and all attachments may be confidential or protected by privilege. If you are not the intended recipient, you are hereby notified that any disclosure, copying, distribution or use of the information contained in or attached to this message is strictly prohibited. Please notify the sender of the delivery error by replying to this message, and then delete it from your system. Thank you.

From: Michael Spitzer-Rubenstein [mailto:michael@voteathome.org]
Sent: Wednesday, October 28, 2020 3:35 PM
To: Vanessa Chavez <Vanessa.Chavez@greenbaywi.gov>
Subject: Re: Election Day Receipt of Ballots

Vanessa, do you have a moment? Can I stop by your office?

On Wed, Oct 28, 2020 at 3:28 PM Vanessa Chavez <Vanessa.Chavez@greenbaywi.gov> wrote:

I think we should have a conversation about it. That's not what I was gathering from anything we discussed, so we should probably talk through logistics.

I realize we are all more comfortable waiting for the WEC to weigh in on election night ballot receipt, it is my legal opinion that the statute is what we should follow, which specifically states that ballots have to be counted if received by the Clerk. As long as we make that abundantly clear at the outset so that there is no confusion about what will be happening come 8p, we should be fine.

Vanessa R. Chavez, *City Attorney*

City of Green Bay

(920) 448-3080

Vanessa.Chavez@greenbaywi.gov

LEGAL DISCLAIMER: This message and all attachments may be confidential or protected by privilege. If you are not the intended recipient, you are hereby notified that any disclosure, copying, distribution or use of the information contained in or attached to this message is strictly prohibited. Please notify the sender of the delivery error by replying to this message, and then delete it from your system. Thank you.

From: Celestine Jeffreys [mailto:Celestine.Jeffreys@greenbaywi.gov]

Sent: Wednesday, October 28, 2020 2:32 PM

To: Vanessa Chavez <Vanessa.Chavez@greenbaywi.gov>; Diana Ellenbecker <Diana.Ellenbecker@greenbaywi.gov>; Kim Wayte <Kim.Wayte@greenbaywi.gov>; Eric Genrich <Eric.Genrich@greenbaywi.gov>

Cc: Michael Spitzer-Rubenstein <michael@voteathome.org>; Ryan Chew <ryan@electionsgroup.com>; Dayna Causby <dayna@electionsgroup.com>; Hillary Hall <hillary@voteathome.org>

Subject: Election Day Receipt of Ballots

Hello!

As we await clarity from the WEC, we should decide, in the worst case scenario, how we check in ballots that come in after the drop boxes have closed (7 pm).

- For the ballots that come into city hall or to the other drop boxes between 9 am and 6:45 pm, Kim would be at CH checking-in those ballots, curing, verifying. The CSOs would deliver the ballots from the drop boxes to Kim, wait for Kim to check in and verify, and then deliver the ballots to KI
- For ballots that come in after the last collection at the drop boxes, the CSOs should deliver those directly to KI

○ Kim and staff would pack up by about 6:45 p

- Kim and staff would sit at a table in the central count room (Grand Ballroom) to receive the ballots from the CSOs as well as voters who need to drop off by 8 pm
- For voters who have to drop off their ballots after 7 pm, but before 8 pm, they'd need to go to KI, we should have DPW bring over the portable drop box and have a staff member stand there.



Celestine Jeffreys

Chief of Staff

Office of the Mayor

920.448.3006

--

Michael Spitzer-Rubenstein

State Lead for Wisconsin (Leadership Now Fellow)

National Vote at Home Institute

(310) 980-2872

he/him



Learn more about:

[Election Officials Center](#)

[Mail Ballot FAQs](#)

[Mail Ballot Security](#)

--

Michael Spitzer-Rubenstein

State Lead for Wisconsin (Leadership Now Fellow)

National Vote at Home Institute

(310) 980-2872

he/him



Learn more about:

[Election Officials Center](#)

[Mail Ballot FAQs](#)

[Mail Ballot Security](#)

Deanna Debruler

From: Michael Spitzer-Rubenstein <michael@voteathome.org>
Sent: Wednesday, October 7, 2020 2:06 PM
To: Kris Teske
Subject: Re: Help with Absentee Ballot Curing Process?

Okay, I wouldn't want to disrupt anything given the date.

Do you have a few moments to speak, though? I've just been working with Celestine and so want to be sure I'm not overlooking any issues or places where we could help you.

Are you free this afternoon, Friday (any time before 3 PM) or Monday afternoon?

Michael

On Wed, Oct 7, 2020 at 2:59 PM Kris Teske <Kris.Teske@greenbaywi.gov> wrote:

We talked to a team already about curing ballots and found that it would take the same amount of time. So we decided our process was working the best for us and it's getting too late in the game to be starting new procedures.

Thank you,

Kris Teske, WCMC

Green Bay City Clerk

100 N. Jefferson St., Rm 106

Green Bay, WI 54301

920-448-3014



From: Michael Spitzer-Rubenstein [mailto:michael@voteathome.org]
Sent: Wednesday, October 7, 2020 9:49 AM
To: Kris Teske <Kris.Teske@greenbaywi.gov>
Subject: Help with Absentee Ballot Curing Process?

Hi Kris,

Can we help with curing absentee ballots that are missing a signature or witness signature/address?

We have a process map that we've worked out with Milwaukee for their process. We can also adapt the letter they're sending out with rejected absentee ballots along with a call script alerting voters (we can also get people to make the calls, too, so you don't need to worry about it). Celestine mentioned curing ballots might be something we could take off your plate.

When would be a good time to talk about it? I'm available this afternoon (after 2 PM), Friday (any time before 3) or next week. Any of those good for you?

Michael

--

Michael Spitzer-Rubenstein

State Lead for Wisconsin (Leadership Now Fellow)

National Vote at Home Institute

(310) 980-2872

he/him



Learn more about:

[Election Officials Center](#)

[Mail Ballot FAQs](#)

[Mail Ballot Security](#)

--

Michael Spitzer-Rubenstein

Deanna Debruler

From: Celestine Jeffreys
Sent: Tuesday, October 6, 2020 1:50 PM
To: Kris Teske; Kim Wayte; Eric Genrich; Diana Ellenbecker; Vanessa Chavez
Subject: RE: Meet Next Week? Ballot Curing

Thanks for letting me know.



Celestine Jeffreys

Chief of Staff
Office of the Mayor
920.448.3006

From: Kris Teske <Kris.Teske@greenbaywi.gov>
Sent: Monday, October 05, 2020 11:49 AM
To: Celestine Jeffreys <Celestine.Jeffreys@greenbaywi.gov>; Kim Wayte <Kim.Wayte@greenbaywi.gov>; Eric Genrich <Eric.Genrich@greenbaywi.gov>; Diana Ellenbecker <Diana.Ellenbecker@greenbaywi.gov>; Vanessa Chavez <Vanessa.Chavez@greenbaywi.gov>
Subject: RE: Meet Next Week? Ballot Curing

Hi,

After Kim and I met with people from the grant team on curing we decided it wouldn't be beneficial to our office and they pretty much agreed that there wouldn't be any time savings. Our main issue was curing requests and they couldn't help us with that. The ballot curing has been going on since we sent out the ballots in September. We really don't have the time to be working on a new process now that we have the ballots.

Thanks,

Kris Teske, WCMC
Green Bay City Clerk
100 N. Jefferson St., Rm 106
Green Bay, WI 54301
920-448-3014



From: Celestine Jeffreys [<mailto:Celestine.Jeffreys@greenbaywi.gov>]
Sent: Saturday, October 3, 2020 1:49 PM
To: Kris Teske <Kris.Teske@greenbaywi.gov>; Kim Wayte <Kim.Wayte@greenbaywi.gov>; Eric Genrich <Eric.Genrich@greenbaywi.gov>; Diana Ellenbecker <Diana.Ellenbecker@greenbaywi.gov>; Vanessa Chavez <Vanessa.Chavez@greenbaywi.gov>
Subject: FW: Meet Next Week? Ballot Curing

Deanna Debruler

From: Michael Spitzer-Rubenstein <michael@voteathome.org>
Sent: Thursday, October 29, 2020 8:49 AM
To: Vanessa Chavez
Cc: Amaad Rivera; Celestine Jeffreys
Subject: Fwd: legal context on accepting ballots at central count after 8pm

Vanessa, Celestine,
Want to make sure you see this.

Michael

----- Forwarded message -----

From: Sam Munger [REDACTED]
Date: Wed, Oct 28, 2020 at 6:10 PM
Subject: legal context on accepting ballots at central count after 8pm
To: Michael Spitzer-Rubenstein <michael@voteathome.org>, Amaad Rivera <amaadr@gmail.com>

Hey Amaad, Michael - I've been doing some digging on the dropbox closing time issue and thought I'd share what I've found out in case it's of help in formulating your plans. Feel free to give me a call to discuss, or to have the City Attorney's office reach out to me directly.

-SM

Here is what the WEC guidance on the issue (<https://elections.wi.gov/sites/elections.wi.gov/files/2020-10/Election%20Night%20Results%20Clerk%20Memo%20FINAL.pdf>) says: "absentee ballots must be delivered to the polling place or the central count facility by 8 p.m. on election night in order to be counted. This means that if a municipality has drop boxes or other drop off locations, the last pick up time needs to be properly noticed to the public to ensure that all ballots eligible to be counted are delivered to the polling place or central count facility no later than 8 p.m." So that seems fairly clear.

But both Ann Jacobs and Nate Judnic at the WEC have acknowledged the statutory scheme is a little more ambiguous. They are relying on the language in Wis State 6.87(6), (<https://docs.legis.wisconsin.gov/statutes/statutes/6/iv/87/6>), which says that "The ballot shall be returned so it is delivered to the polling place no later than 8 p.m. on election day. ...Any ballot not mailed or delivered as provided in this subsection may not be counted." They think that reading that strictly, as a best practice and to be consistent with those municipalities that count absentee ballots at the polling place, means that a municipality should get all dropbox ballots to a central count facility by 8pm.

That said, Nate acknowledged that based on the language in 7.52 (<https://docs.legis.wisconsin.gov/statutes/statutes/7/ii/52>) there is an argument that such ballots just need to be "received by the municipal clerk" by 8pm which is different than being at central count by 8pm. However, **that argument has not been tested and any municipality that relies on it would have to be prepared for a possible challenge to any ballots arriving at central count after 8pm, and for those ballots not to count if they lost in court.** So, the WEC's guidance erred on the side of safety, and that's what we are recommending municipalities do.

That said, Claire in Milwaukee is taking the approach that, should something interfere with ballots arriving by 8pm to central count from a dropbox (e.g. retrieval team blocked by car accident, protest, etc), she is ready and willing, if challenged, to make a legal argument that the ballots should still be accepted. Essentially, she believes there's a strong legal argument for accepting delayed ballots (voted at the dropbox, picked up before 7:30pm, but not back at central count), and her default will be to accept them after 8pm if they're coming from dropboxes.

That being said, she is sticking with closing the dropboxes at 7:30pm -- so there's still the issue of the 7:30-8pm voters, who will need to go directly to central count or their nearest precinct. (Deadline has been updated on official materials, a postcard has gone out with the new deadline to all absentee voters that have yet to submit their ballots, and Sam M is exploring having volunteers at the dropboxes at 7:30pm to help voters navigate their options once the dropboxes are closed.)

On Wed, Oct 28, 2020 at 11:53 AM Wittenwyler, Mike <mwittenw@gklaw.com> wrote:

Spoke to Nate at the WEC.

As a best practice and to be consistent with those municipalities that count absentee ballots at the polling place, a municipality should get all dropbox ballots to a central count facility by 8pm. That said, Nate acknowledges the language in 7.52 and the argument that such ballots just need to be "received" by the municipal clerk by 8pm which is different than being at central count by 8pm. However, that argument has not been tested and any municipality that does otherwise needs to recognize a possible challenge to any ballots arriving at central count after 8pm.

And, he closed by saying that the WEC is working to schedule a check-in call with all the central count municipalities in the next day to coordinate activities and answer question.

--
Michael Spitzer-Rubenstein
State Lead for Wisconsin (Leadership Now Fellow)
National Vote at Home Institute
(310) 980-2872
he/him



Learn more about:
[Election Officials Center](#)
[Mail Ballot FAQs](#)
[Mail Ballot Security](#)

Deanna Debruler

From: Saralynn Finn <saralynn@voteathome.org>
Sent: Thursday, October 15, 2020 12:52 PM
To: Kris Teske
Cc: Shelby Edlebeck; Mike Hronek; Celestine Jeffreys; Diana Ellenbecker
Subject: Re: Livestream Central Count

Just wanted to share an example of how Denver does livestream for inspiration.

Best,
Saralynn

On Sun, Oct 11, 2020 at 1:58 PM Saralynn Finn <saralynn@voteathome.org> wrote:
Hey Kris-

I don't think we've gotten a chance to 'meet' yet. My name is Saralynn Finn, I'm a Communications Strategist with NVAHI. We just published a white paper in conjunction with the Carter Center with tips for transparency in elections. I'm supporting jurisdictions to implement as many of them as possible.

I know there are concerns about space in your Central Count and also the ongoing COVID situation in Green Bay and the difficulty of social distancing with observers, this seemed like a potential solution to these two issues. Let me know if I can help in any way.

Best,
Saralynn

On Sat, Oct 10, 2020 at 4:03 PM Kris Teske <Kris.Teske@greenbaywi.gov> wrote:

Hi Shelby,

This is the first I heard of this so I don't have anything drawn up yet.

The plan is to have Central Count on 1st floor again (down the three halls). There will not be any DS 200 tabulators in the hall but I am planning on the DS 450 being in the Clerk's lobby. The observer area will be across the hall from the Clerk Office doors like before.

Let me know if you need anything else.

Kris Teske, WCMC

Green Bay City Clerk

100 N. Jefferson St., Rm 106

Green Bay, WI 54301

920-448-3014



From: Shelby Edlebeck [mailto:Shelby.Edlebeck@greenbaywi.gov]
Sent: Friday, October 9, 2020 12:22 PM
To: Kris Teske <Kris.Teske@greenbaywi.gov>
Cc: Mike Hronek <mike.hronek@greenbaywi.gov>; Saralynn Finn <saralynn@voteathome.org>; Celestine Jeffreys <Celestine.Jeffreys@greenbaywi.gov>
Subject: RE: Livestream Central Count

Hi Kris,

We are brainstorming how we would 'livestream' the central count taking place at City Hall on November 3rd. Do you have any ideas of what you are envisioning for this?

I was thinking of setting up laptops throughout the work zone with the cameras turned on (but mics muted) and streaming to a Zoom meeting. Then we could post the Zoom link on our website or email it out to whoever was interested in observing. Or whatever the protocol is for transparency during central count.

Let us know your thoughts or what you were thinking! ☺

Thank you,

Shelby Edlebeck

920.448.3207

From: Celestine Jeffreys
Sent: Thursday, October 8, 2020 5:15 PM
To: Shelby Edlebeck <Shelby.Edlebeck@greenbaywi.gov>
Cc: Mike Hronek <mike.hronek@greenbaywi.gov>; Saralynn Finn <saralynn@voteathome.org>
Subject: RE: Livestream Central Count

Shelby and Mike,

This sounds fine. Kris is the person to really determine where livestreaming needs to take place. I would imagine at each of the steps of the process not just tabulating the ballots.



Celestine Jeffreys

Chief of Staff

Office of the Mayor

920.448.3006

From: Shelby Edlebeck <Shelby.Edlebeck@greenbaywi.gov>
Sent: Thursday, October 08, 2020 3:04 PM
To: Mike Hronek <mike.hronek@greenbaywi.gov>; Celestine Jeffreys <Celestine.Jeffreys@greenbaywi.gov>
Subject: Livestream Central Count

I just got off the phone with Saralynn Finn and I'm brainstorming how we can livestream Central Count on election day so that observers do not enter our building.

My first thought is that we could "livestream" by basically just having a Zoom meeting all day.

Set up laptops with their cameras facing the big DS200 machines and having all laptops on mute and joined into the same Zoom meeting. Then we can post that Zoom meeting link on our website for observers. I can probably figure out a way to make sure people cannot unmute themselves and have conversations in the Zoom meeting throughout the day? It would just be a silent "livestream".

First things first, **Mike** – do you think we could muster up a few laptops to use that day?

Secondly, **Celestine** – do you like this idea? Where would you want the cameras on the laptops facing? At the DS200 machines or elsewhere?

Shelby Edlebeck

Multimedia Communication Specialist

City of Green Bay

920.448.3207

Deanna Debruler

From: Celestine Jeffreys
Sent: Wednesday, October 14, 2020 4:16 PM
To: Isabel Brinker; Jennifer Savino; Doug Hutchison; Sam Hutchison; Ariana Saravia Coira; Ariana Saravia Coira; Saralynn Finn; Shelby Edlebeck; Kris Teske; Kim Wayte
Subject: RE: Radio spots for approval

All approved on my end! Like the voice and the guitar music!

Celestine Jeffreys
Chief of Staff, Mayor's Office
City of Green Bay

From: Isabel Brinker <IBrinker@kw2madison.com>
Sent: Wednesday, October 14, 2020 2:28 PM
To: Celestine Jeffreys <Celestine.Jeffreys@greenbaywi.gov>; Shelby Edlebeck <Shelby.Edlebeck@greenbaywi.gov>; Kris Teske <Kris.Teske@greenbaywi.gov>; Saralynn Finn <saralynn@voteathome.org>
Cc: Jennifer Savino <JSavino@kw2madison.com>; Doug Hutchison <doug@hvsproductions.com>; Sam Hutchison <sam@hvsproductions.com>; Ariana Saravia Coira <acoira@kw2madison.com>
Subject: Radio spots for approval
Importance: High

Hi everyone,

We've produced the three :60second radio spots in English, they are attached to this email and we will need your final approval before we send to the stations. Celestine, if you could be the person to provide final approval of these spots that would be great. We're working on the Spanish translations and will send those spots for approval as soon as they're ready.

Please let us know if you have any questions. Thank you!
Izzy

Isabel Brinker

Account Manager

KW2

2010 Eastwood Drive, Ste. 300
Madison, WI 53704

608-232-2300 | KW2Madison.com



Empower & Improve Lives

Deanna Debruler

From: Celestine Jeffreys
Sent: Thursday, August 13, 2020 7:03 PM
To: 'Whitney May'
Subject: FW: Capturing video footage of today's mail ballot process in Green Bay

Follow Up Flag: Follow up
Flag Status: Completed

Whitney,

How about this video?



Celestine Jeffreys

Chief of Staff
Office of the Mayor
920.448.3006

From: Shelby Hearley [mailto:Shelby.Hearley@greenbaywi.gov]
Sent: Wednesday, August 12, 2020 2:17 PM
To: Celestine Jeffreys; Kris Teske; Kim Wayte
Subject: RE: Capturing video footage of today's mail ballot process in Green Bay

Sorry about the link below. Please try this one instead:

https://drive.google.com/file/d/1dULH4_ksuz55vGWtfDb7DBZyLyxApB91/view?usp=sharing

Thank you,

Shelby Edlebeck

920.448.3207

From: Shelby Hearley
Sent: Wednesday, August 12, 2020 10:38 AM
To: Celestine Jeffreys <Celestine.Jeffreys@greenbaywi.gov>; Kris Teske <Kris.Teske@greenbaywi.gov>; Kim Wayte <Kim.Wayte@greenbaywi.gov>
Subject: RE: Capturing video footage of today's mail ballot process in Green Bay

I very quickly threw this iPhone video together. Let me know your thoughts and any edits you want me to make!

https://drive.google.com/file/d/1dULH4_ksuz55vGWtfDb7DBZyLyxApB91/view?usp=sharing

From: Celestine Jeffreys <Celestine.Jeffreys@greenbaywi.gov>
Sent: Tuesday, August 11, 2020 2:55 PM
To: Kris Teske <Kris.Teske@greenbaywi.gov>; Kim Wayte <Kim.Wayte@greenbaywi.gov>; Shelby Hearley <Shelby.Hearley@greenbaywi.gov>
Subject: FW: Capturing video footage of today's mail ballot process in Green Bay

All—

Shelby, can you take some footage of the clerk's office handling mail ballots? (See below.) No audio necessary. This is to show voters how secure their mailed ballots are.

This can take place at any time today.

Thanks!!

Celestine Jeffreys
Chief of Staff, Mayor's Office
City of Green Bay

From: Whitney May [<mailto:whitney@techandciviclife.org>]
Sent: Tuesday, August 11, 2020 12:58 PM
To: Celestine Jeffreys <Celestine.Jeffreys@greenbaywi.gov>
Cc: Ryan Chew <ryan@electionsgroup.com>
Subject: Capturing video footage of today's mail ballot process in Green Bay

Hi Celestine,

Happy Election Day! Hope all is going smoothly for you and your team in Green Bay.

I'm reaching out with a suggestion from Ryan Chew, the Elections Group state lead for Wisconsin. Elections Group is one of the technical assistance partners available to support your office. Ryan is cc'd. He and his team will be connecting with you in the coming days regarding drop boxes for November.

For today's operations, Ryan suggests getting some video footage of the Clerk's office handling mail ballots that can be used for public messaging in November.

It can be shot on a decent smartphone, no narration needed, while capturing as many steps in the process as possible. The goal of the footage is to promote the security and transparency of the mail ballot process to your November voters.

I know this is a last-minute suggestion and your hands are already more than full today, so consider this a "nice-to-have" not a "must-have". No worries if you can't get to it — just an idea.

Stay safe,
Whitney

--
Whitney May
Director of Government Services
Center for Tech and Civic Life
whitney@techandciviclife.org
(919) 799-6173
she/her

Deanna Debruler

From: Celestine Jeffreys
Sent: Tuesday, August 11, 2020 2:54 PM
To: Whitney May
Subject: RE: Capturing video footage of today's mail ballot process in Green Bay

Follow Up Flag: Follow up
Flag Status: Completed

I will get on the suggestion right now. We have a staffer who might be able to help.

I'll email Ryan in a jiffy, thanks!!

Celestine Jeffreys
Chief of Staff, Mayor's Office
City of Green Bay

From: Whitney May [mailto:whitney@techandcivicliflife.org]
Sent: Tuesday, August 11, 2020 12:58 PM
To: Celestine Jeffreys <Celestine.Jeffreys@greenbaywi.gov>
Cc: Ryan Chew <ryan@electionsgroup.com>
Subject: Capturing video footage of today's mail ballot process in Green Bay

Hi Celestine,

Happy Election Day! Hope all is going smoothly for you and your team in Green Bay.

I'm reaching out with a suggestion from Ryan Chew, the Elections Group state lead for Wisconsin. Elections Group is one of the technical assistance partners available to support your office. Ryan is cc'd. He and his team will be connecting with you in the coming days regarding drop boxes for November.

For today's operations, Ryan suggests getting some video footage of the Clerk's office handling mail ballots that can be used for public messaging in November.

It can be shot on a decent smartphone, no narration needed, while capturing as many steps in the process as possible. The goal of the footage is to promote the security and transparency of the mail ballot process to your November voters.

I know this is a last-minute suggestion and your hands are already more than full today, so consider this a "nice-to-have" not a "must-have". No worries if you can't get to it — just an idea.

Stay safe,
Whitney

--

Whitney May
Director of Government Services
Center for Tech and Civic Life
whitney@techandcivicliflife.org
(919) 799-6173
she/her

Deanna Debruler

From: Celestine Jeffreys
Sent: Tuesday, August 11, 2020 2:55 PM
To: Kris Teske; Kim Wayte; Shelby Edlebeck
Subject: FW: Capturing video footage of today's mail ballot process in Green Bay

All—

Shelby, can you take some footage of the clerk's office handling mail ballots? (See below.) No audio necessary. This is to show voters how secure their mailed ballots are.

This can take place at any time today.

Thanks!!

Celestine Jeffreys
Chief of Staff, Mayor's Office
City of Green Bay

From: Whitney May [mailto:whitney@techandcivicliflife.org]
Sent: Tuesday, August 11, 2020 12:58 PM
To: Celestine Jeffreys <Celestine.Jeffreys@greenbaywi.gov>
Cc: Ryan Chew <ryan@electionsgroup.com>
Subject: Capturing video footage of today's mail ballot process in Green Bay

Hi Celestine,

Happy Election Day! Hope all is going smoothly for you and your team in Green Bay.

I'm reaching out with a suggestion from Ryan Chew, the Elections Group state lead for Wisconsin. Elections Group is one of the technical assistance partners available to support your office. Ryan is cc'd. He and his team will be connecting with you in the coming days regarding drop boxes for November.

For today's operations, Ryan suggests getting some video footage of the Clerk's office handling mail ballots that can be used for public messaging in November.

It can be shot on a decent smartphone, no narration needed, while capturing as many steps in the process as possible. The goal of the footage is to promote the security and transparency of the mail ballot process to your November voters.

I know this is a last-minute suggestion and your hands are already more than full today, so consider this a "nice-to-have" not a "must-have". No worries if you can't get to it — just an idea.

Stay safe,
Whitney

--
Whitney May
Director of Government Services
Center for Tech and Civic Life
whitney@techandcivicliflife.org
(919) 799-6173
she/her

Deanna Debruler

From: Celestine Jeffreys
Sent: Friday, August 28, 2020 1:13 PM
To: 'Haley McKean'; 'Dayna Causby'; Ryan Chew; Kris Teske
Subject: Re: Communications

Hello!!

We put out an rfp for a public affairs firm and are working with Eric from modern elections.

Hope that helps!

Sent from my Verizon, Samsung Galaxy smartphone
Get [Outlook for Android](#)

From: Kris Teske <Kris.Teske@greenbaywi.gov>
Sent: Friday, August 28, 2020 12:06:03 PM
To: 'Haley McKean' <haley@electionsgroup.com>; 'Dayna Causby' <dayna@electionsgroup.com>; Celestine Jeffreys <Celestine.Jeffreys@greenbaywi.gov>; Ryan Chew <ryan@electionsgroup.com>
Subject: RE: Communications

1 pm works for me

Kris Teske, WCMC
Green Bay City Clerk
100 N. Jefferson St., Rm 106
Green Bay, WI 54301
920-448-3014



From: Haley McKean [mailto:haley@electionsgroup.com]
Sent: Friday, August 28, 2020 10:07 AM
To: Kris Teske <Kris.Teske@greenbaywi.gov>; 'Dayna Causby' <dayna@electionsgroup.com>; Celestine Jeffreys <Celestine.Jeffreys@greenbaywi.gov>; Ryan Chew <ryan@electionsgroup.com>
Subject: Re: Communications

Hi Dana, could you please ask Kris if she could do 1 PM central time? That's 12 PM my time in the Rockies. Hopefully that gives her time to grab some lunch first.

Will you be arranging the zoom call?

Thanks!
Haley McKean

From: Kris Teske <Kris.Teske@greenbaywi.gov>
Sent: Friday, August 28, 2020 8:30 AM
To: 'Dayna Causby'; Celestine Jeffreys; Ryan Chew; Haley McKean
Subject: RE: Communications

Hi,

I am available after noon on Monday.

Kris Teske, WCMC
Green Bay City Clerk
100 N. Jefferson St., Rm 106
Green Bay, WI 54301
920-448-3014



From: Dayna Causby [<mailto:dayna@electionsgroup.com>]
Sent: Friday, August 28, 2020 7:32 AM
To: Celestine Jeffreys <Celestine.Jeffreys@greenbaywi.gov>; Kris Teske <Kris.Teske@greenbaywi.gov>; Ryan Chew <ryan@electionsgroup.com>; Haley McKean <haley@electionsgroup.com>
Subject: Communications

Kris & Celestine,
During our meeting Tuesday you mentioned some concerns regarding communications to voters and critical stakeholders. I would like to bring in Haley McKean to help you around that. I know you are looking for a communications firm, she maybe able to help guide you through some election specific communication strategies.

Would you be free Monday after 11am to chat and see how we can help with this?

--

Thank you,
Dayna Causby, CERA
The Elections Group

"Voting is the expression of our commitment to ourselves, one another, this country and this world"
~Sharon Salzberg



THE
ELECTIONS
GROUP

Guide to Ballot Drop Boxes

Issued by The Elections Group

Table of Contents

Overview	2
Planning	3
How Many Ballot Drop Boxes Do I Need?	3
Where Do I Place Them?.....	4
Purchasing Considerations.....	6
What Other Resources Will I Need?	13
How Do We Secure Ballot Boxes?	14
Ballot Retrieval	15
Driving Routes, Frequency, and Staffing Needs	15
Voter Outreach and Communication	18
Execution	19
Opening and Setup	19
Daily Collection of Ballot Drop Boxes	22
Election Night Closing	27
Common Mistakes and How to Prevent Them	30
Appendix A: Drop Box Vendors	31
Appendix B: Site Feasibility Planner	34



The Elections Group, 2020
This work is licensed under the Creative Commons Attribution-NonCommercial 4.0 International License. To view a copy of the license, visit creativecommons.org/licenses/by-nc/4.0.

Overview

Ballot drop boxes offer a secure, convenient alternative for voters to cast their completed mail ballots. They save money for voters in jurisdictions where return postage is not prepaid, and they can reduce costs for election authorities where postage is paid.

Voters like ballot drop boxes. In jurisdictions where vote-by-mail is prevalent, as many as 80 percent of voters choose to return their ballot at a ballot drop box.

A ballot drop box program can help build public trust in the election process. Ballot drop boxes can reassure voters who mistrust the postal system because of lost or delayed mail, or who worry about someone potentially tampering with their ballot. Ballot drop boxes also provide a solution for voters who are concerned about their signature being exposed to anyone outside of their local election office.

For election officials, ballot drop boxes ensure ballots are received in time to be processed. This is critical since many voters wait until Election Day to return their ballots.

This guide is divided into three sections.

- **Planning** will help election officials decide the type, location, equipment and staffing for three types of ballot drop boxes.
- **Voter Outreach and Communication** contains suggestions for promoting ballot drop box convenience and availability, and to publicize your request and return deadlines.
- **Execution** includes sample forms that can be used separate from this guide to train temporary staff and used as a daily checklists and chain of custody logs, including a section for Election Night.

As you review this guide, keep in mind accommodations for COVID-19 and social distancing requirements. For example, asking two unrelated workers to share a car ride may be a challenge. COVID-related considerations are addressed in the Planning section.

Planning

How Many Ballot Drop Boxes Do I Need?

Estimating an adequate number of ballot drop boxes can be challenging when you don't know how many voters will use them. And determining how many to obtain will be constrained by your budget, purchasing process, and ability to deploy multiple boxes before Election Day.

Hiring enough temporary workers to staff ballot security teams is another critical factor. To maintain public trust you should have bipartisan, two-person teams picking up ballots from each drop box on a daily basis. You will need more frequent pick-ups in the days leading up to and including Election Day. Early on, some busy locations may also require frequent pick-ups, perhaps multiple times a day.

The benefits to deploying as many ballot drop boxes as possible include:

- Providing greater access to the election process
- Keeping voters out of busy and stressful polling places on Election Day
- Receiving voted ballots back faster than USPS delivery

A rule of thumb to consider is one drop box for every 10,000-15,000 voters; that is a common requirement in states where mail ballots are the primary voting method. Your geography should also inform how many drop boxes to place. For example, rural, sparsely populated areas may require more drop boxes per capita than densely populated urban areas.

Fewer drop boxes will yield fewer benefits. An overflowing, unstaffed 24-hour ballot drop box can become a serious public relations and voter trust issue. If mailing out ballots is a temporary pandemic alternative, or if you don't have an adequate budget, temporary indoor ballot drop boxes at staffed locations can provide an adequate solution.

Scaling Up

Ballot drop boxes should be available to voters as soon as ballots are mailed and remain available through the close of polls on Election Day (or as the statute in your state provides). Unstaffed drop boxes are usually available 24 hours per day. Staffed drop boxes or drive-up options are

typically offered on a more limited schedule, such as during business hours and full polling hours on Election Day.

If adequate staffing is a problem, consider starting with fewer drop boxes and scaling up to the full number you need closer to Election Day. Note that scaling up over time presents P.R. challenges. You will need to clearly publicize drop box locations, plus the dates and times that each location is available.

Where Do I Place Them?

To choose ballot drop box locations, election officials should consider these factors at a minimum:

- Concentrations of population
- Concentrations of historically higher mail-voting populations
- Geographic distance and features
- Voter convenience
- Proximity to public transportation
- Community-based locations
- Security, including lighting, visibility, and security cameras

The Center for Tech and Civic Life (CTCL) created a [Ballot Drop-off Location Criteria Planner](#) to help jurisdictions evaluate potential ballot drop-off locations. The planner is located in Appendix B.

Unless prohibited by law, a staffed ballot drop box should be provided at every polling location. This will require separate drop boxes for mail ballots and in-person paper ballots (when not scanned at the polling location).

Additional locations for staffed drop boxes may include, but are not limited to: city offices, public libraries, county offices, assisted living facilities, senior living communities, college campuses, local businesses and shopping centers, and offices of community organizations. At these locations, the voter may need to leave their vehicle and enter the building. A drive-up option could allow voters to deposit their ballots and remain in their vehicles.

ADA Accessibility

Election officials should ensure that ballot drop box locations are accessible to voters with disabilities. Consider the following when implementing drop box plans.

1. If a location has only one drop box, the design and placement of that drop box should meet accessibility requirements.
2. If a location has more than one drop box, at least one of the drop boxes should meet accessibility requirements. Any inaccessible drop box at a facility should have a sign with directions to the nearest accessible drop box.
3. A drop box should be placed along an accessible path connected to the nearest ADA parking space, or nearest the passenger drop-off zone, and if applicable, the nearest public transportation stop.
4. If there is no accessible pathway from the parking lot, there should be signs directing the voter to the nearest accessible drop box.
5. Drop box locations inside of buildings should be assessed for accessibility as if they were polling places. For more information, please see the [ADA Checklist for Polling Places](#).

Purchasing Considerations

The type of ballot drop box(es) you use will depend on your plan and budget. Drop boxes come in several sizes, types, and different construction materials to with stand vandalism and inclement weather and to prevent removal. The following section will cover three types of ballot boxes: a 24-hour permanent box, a temporary indoor box and a temporary drive-through ballot drop-off.

24-Hour Unstaffed Ballot Drop Box

A 24-hour ballot drop box mimics a USPS blue mailbox. It is a permanent metal structure accessible by vehicle or on foot in the public right-of-way, and should be well-secured to the ground. Styles vary. These can be installed on your jurisdiction's property, or you can arrange to install one at a partnering public agency (see list in previous section.) This usually means securing a written agreement with property owners to locate and secure these drop boxes on their property before you purchase them. A list of drop box vendors is located in Appendix A.



Some things to consider when purchasing 24-hour, unstaffed ballot drop boxes:

- The drop box should be a permanent fixture or a temporary structure that is secured in place to prevent removal or tampering.
- Ensure that the ballot drop box has robust locking mechanisms for both the ballot slot(s) and storage compartment. Ensure that ballots cannot be tampered with while in the drop box, nor removed by anyone other than your authorized ballot retrieval team.
- The opening slot should be large enough to deposit ballot envelopes and designed to keep anyone from pouring liquid into the drop box, or for rainwater to seep into it.
- Drop boxes should be easily recognizable by voters. Plan to purchase or produce permanent, large, weather-proof decals to label the drop boxes with at least your agency name, logo, phone number and the words *Official Ballot Drop Box*. Use consistent decals on all 24-hour boxes. Additional language may include:
 - *No Postage Required*
 - *Closes at 7 p.m. on Election Day* (or relevant time)
 - *This Box Under Video Surveillance* (if applicable)
 - If required, list any statutory language, such as the number of ballots that can be dropped off by one person in any election.
- Find out how many ballot envelopes each different brand or style of drop box can hold. Ballot return projections will help you to determine the drop box size you will need.
- Consider whether your jurisdiction can or must monitor the ballot drop box with 24/7 video surveillance, where the camera will be mounted, and how footage will be stored. If the drop box is located at another agency's facility, include mounting and access requirements in the agreement.
- If the ballot drop box is accessible by vehicle, consider whether you can safely locate it on the driver's side. This can ensure safety by letting the driver cast their ballot without exiting the vehicle. "One-Way" streets/thoroughfares are ideal for installing a box on the driver's side.
- When planning to receive a shipment of drop boxes, consider multiple important factors.
 - These drop boxes will arrive on pallets and are large and heavy.
 - They should be shipped to a warehouse.

- Installation may not take place immediately and you may need space to store them.
- A forklift may be needed to move them.
- While drop boxes have few moving parts, it is crucial that you verify the locks and doors are functioning properly and that all ballot slots are unobstructed before acceptance.

To install drop boxes you may need an agreement or permit from the local governing body before installing a drop box. Once an agreement and/or permit is secured, you may need to coordinate work with other offices to complete installation. Some items to consider:

- New concrete may need to be poured, which may extend the timeline for the boxes to be safe and fully functional.
- Consider drop box weight and bulk before shipping them out for installation. Consider which staff and vehicles are appropriate, and how the boxes will move in and out of the vehicle cargo area.
- Securing the boxes will require tradespeople whose schedules may not be flexible if shipment is delayed.
- Early and regular communications will help keep the team working together.

Temporary Ballot Drop Boxes — Indoors

Temporary indoor ballot drop boxes or bags are portable and much smaller than 24-hour drop boxes. Smaller options have handles on the side for carrying and are small enough to rest on a table. Larger options can hold more ballots and are on wheels. Bipartisan teams of two election workers usually monitor these drop boxes or bags.

Ideally, these drop boxes or bags should be available inside every polling place, to offer voters the greatest convenience for dropping off mail ballots. Ballot drop boxes placed inside the polling location may be serviced and staffed by poll workers rather than separate ballot collection teams.

They can also be located inside government buildings, libraries, community centers, and other high traffic areas. Your agency could secure an agreement to have staff from these partnering agencies monitor the drop box during their business hour and during polling hours on Election Day. The agreement should ensure access for your ballot retrieval team to pick up the ballot drop box or bag at scheduled times.

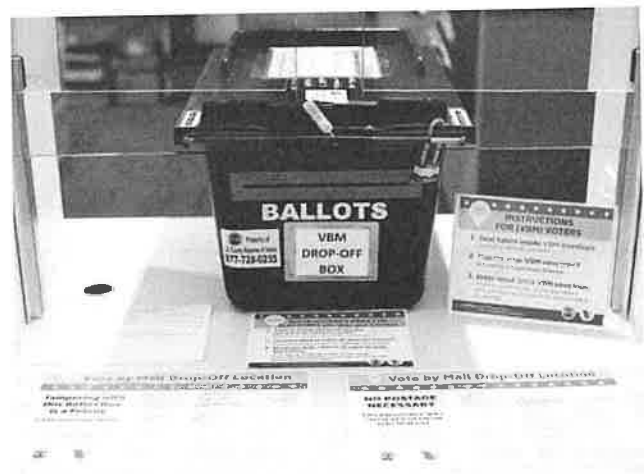

Factors to consider when purchasing temporary, indoor ballot drop boxes or bags:

- Consider durability, weight and sizing options, and which would be a better solution for your facility—a smaller, tabletop box, a bag, or a larger box on wheels.
- Determine how many ballots each drop box or bag can hold and your requirements for replacing or emptying it. Ballot drop boxes fill up quickly, especially approaching and on Election Day.
- Ensure that the drop box or bag cannot be opened or moved by unauthorized persons. It should have a lock to protect ballot envelopes, and ideally should be secured to an immovable object with a padlock or chain lock (such as a bicycle lock).
- Ensure that there is a place on the drop box or bag for a zip-tie style security seal for chain of custody.
- The drop box or bag should be easily recognizable by voters. Plan to purchase or produce decals to label it with your agency name, branding, the purpose of the drop box and useful information (see the section on Voter Outreach and Communication).

Temporary Ballot Drop Boxes — Drive Through

A drive-through ballot drop box is staffed by bipartisan teams of two election workers on a street or in a parking lot. These workers safely approach a vehicle, accept the voted ballot envelope from the voter, and deposit it into a ballot drop box while the voter observes. At minimum, these workers are equipped with safety vests and badges, a canopy tent for shelter, a table and chairs and locked ballot boxes. This option is usually only deployed on the last few days of the election, including Election Day.

Drive-through locations can be very convenient for voters as they do not need to park or exit their vehicles. They also offer greater operational efficiency for election administrators because they can absorb some of the traffic from high-demand, 24-hour ballot drop boxes on Election Day.



To avoid long lines of cars potentially blocking roadways and/or parking lots, ensure that you have enough staff and ballot drop boxes to move traffic through quickly. Also, some jurisdictions provide “I Voted” stickers at drive-through locations. While this can be a fun idea, it has the potential to slow the pace of cars through the process, creating longer lines. Be sure to consider this impact in your planning.

Some things to consider for temporary, drive-through drop off locations:

- To maximize safety and efficiency, provide instructions and maps to set-up teams. These should map out exactly where set-up should take place and how traffic should flow well in advance of deployment.

- Pop-up tents, tables, chairs, safety cones, and portable space heaters can often be borrowed from other government agencies (Sheriff's Office, Public Works, Parks & Recreation, Facilities or Fleet) or rented from a party or restaurant supply company.

Additional supplies are necessary for staff working outdoors, such as spotlights and flashlights for working in the dark, and apparel for inclement weather.

What Other Resources Will I Need?

Additional Supplies and Equipment for All Types of Ballot Drop Boxes

Bipartisan ballot retrieval teams

(Enough teams to ensure each drop box is closed/locked at “close of polls” on Election Night)

Phone tree to reach bipartisan teams while in the field

(May need to provide mobile phones for those who do not want to use their personal phones)

Rental cars or fleet vehicles

Chain of custody logs

Security seals

Portable ballot drop boxes or bags for transport

High-visibility vests for workers

Personal protective equipment such as gloves, masks, and hand sanitizer

Accessibility, directional, and electioneering signs (if applicable)

Temporary Indoor

Table(s)

Chairs

Cable or bike lock

Temporary Drive-Through

Table(s)

Chairs

Pop-up canopy

Road signs

Orange cones

Lanterns

Flashlights

Weather appropriate support such as propane heater and rain gear

Permanent 24-Hour

Extra keys made

Large mail bin placed inside

Flashlights

How Do We Secure Ballot Boxes?

The location and type of drop box can affect the security measures needed to ensure both actual and perceived security.

Locking Requirements

All drop boxes shall be secured by a lock and a tamper-evident seal. Only an election official and a designated ballot retriever shall have access to the keys and/or combination of the lock. If your drop box(es) are secured by a key lock, be sure to make copies of each key and store them securely at your election facility.

Video Requirements

If feasible, both temporary and 24-hour drop boxes should be monitored by a video security surveillance system, or an internal camera that can capture digital images and/or video.

A video security surveillance system is especially critical for unstaffed, 24-hour boxes and can include existing systems on county, city, or private buildings. The video system should be robust enough to capture and store video for the full time the ballot drop box(es) are open to receive ballots during an election. These videos may be considered an election record, and thus may need to be retained for a certain period of time after each election, depending on your state laws.

The easiest way to provide video surveillance is to position your ballot drop box within view of an existing video surveillance system. If you need to install your own system, work with your city/county IT, facilities, or law enforcement division to see if there are similar systems used throughout the city/county. Chances are your jurisdiction already has a vendor set up for this type of equipment.

Bipartisan Election Workers (drive-through locations)

Drive-through ballot drop boxes must be monitored very closely by election workers to ensure that someone does not drive-off with a ballot drop box.

Other Safety and Security Measures

Unstaffed drop boxes placed outdoors should be securely fastened to prevent moving or tampering. For example, fasten the drop box to concrete or an immovable object. This will prevent unauthorized removal of the drop box.

Staffed drop boxes have several options, but all options should take into consideration additional security measures when the ballot drop site is not staffed. Safeguarding the drop box during unstaffed hours could mean the drop box is inaccessible to the public when not in use. The box should be secured in a locked room, sealed with a tamper-evident seal, and if possible, under video surveillance. Staffed drop boxes should be securely fastened to a stationary surface or to an immovable object, and/or placed behind a counter, and/or portable so they can be transported to a curbside area or a mobile voting area. When in use, these drop boxes should be constantly monitored by election officials or other designated representatives.

Work with law enforcement to include frequent patrols of unstaffed drop boxes. In some communities, it might also be appropriate to develop a network of citizens willing to regularly patrol unstaffed drop boxes.

Work with the public works department and law enforcement to make drive through locations safe and secure.

Ballot Retrieval

Driving Routes, Frequency, and Staffing Needs

Once the locations of your ballot drop boxes are set, you should begin planning daily routes for ballot retrieval. This includes sending teams to visit all ballot drop boxes - permanent and temporary. The frequency of pickups may vary in the beginning, every other day versus every day, and become more frequent - multiple times per day - the closer you get to Election Day.

The time it takes to retrieve ballots will depend on the type of ballot drop box used. Ballot retrieval teams will be able to park close to most permanent, 24-hour drop boxes. They will need to transfer the contents of the drop boxes to portable bags or boxes, seal the boxes, complete their chain of custody paperwork, and load the portable boxes into a vehicle.

Temporary, staffed ballot drop boxes are usually located inside a building. This means ballot retrieval teams will need to park and walk into the building to the room where the temporary ballot drop box is located. Most often, they will switch out the full ballot drop box for an empty

drop box, complete the chain of custody paperwork, and carry the full drop box or bag back to their vehicle. The process for temporary drive-through locations will be similar.

Driving Routes

The process of retrieving ballots will be most efficient if retrieval teams are able to follow pre-planned driving routes. This can be made easier with mapping technology. Some election offices use commercial software such as Routific and Esri Workforce. Google Maps is a free option that most staff will be familiar with and find easy to use.

When using Google Maps, begin by mapping out a route that you think can be completed in four hours. Identify each location, including the starting and ending location (typically the election office). Assume that the necessary steps at each location will take approximately 15 minutes to complete. Adjust the number of drop boxes on the route until you are able to achieve a route that can be completed in roughly four hours. Be sure to map it during the same times your retrieval team members will be on the road to account for daily traffic patterns. Also consider adding in break times as needed for your retrieval teams.

Consider using mobile phone tracking applications or GPS spot trackers as a way to ensure the assigned route is followed without deviation and that your retrieval team is on time. This may also help document your chain of custody.

Frequency of Retrieval

The frequency with which you retrieve ballots from each ballot drop box depends on multiple factors, including:

- Timing (How close to Election Day is it?)
- Projected and actual voter turnout
- The number of ballot boxes you have
- How many ballots each box can hold
- The geography of your jurisdiction and distance retrieval teams have to travel

Generally, it is important to retrieve ballots at least once per day from the first day ballots may be returned. This will ensure ballot security and the ballots can enter your processing operation as quickly as possible. From there, structure your retrieval plan around a slowly building stream of ballots. Jurisdictions have seen as few as 20% of ballots cast by mail deposited in drop boxes during the first two weeks and as many as 55%–60% of ballots deposited during the last two days

of the election, including 40% of ballots cast on Election Day. You will need to retrieve ballots multiple times per day from your busier ballot drop boxes the closer you get to and on Election Day.

Other important items to consider when creating your retrieval plan:

- Your plan needs to be flexible. If voter turnout is higher than anticipated, you may need to retrieve ballots multiple times per day sooner than you had planned to scale up.
- On the Monday evening before Election Day, you must retrieve ballots from all drop boxes at the end of the day so they do not fill overnight and to maximize the number of ballots you can count on Election Day.
- On Election Night, you must close all drop boxes simultaneously with closing the polls. This will take significant staffing and coordination.
- It is important to track as much data about this process as possible. Retain it for future planning, including how many ballots you retrieve from each drop box each day and how many retrieval runs were needed to each drop box each day. This data can be obtained from ballot logs and reviewed after the election.

Staffing Needs

Use the mapped driving routes and frequency of retrieval to determine how many teams and vehicles you will need and for how long. For example, in the first few weeks after ballots are mailed out you might only need three teams of two (six temporary workers) and three vehicles. That number might increase significantly or even double as you start the week leading up to Election Day.

The biggest staffing challenge for ballot retrieval will be at the close of polls on Election Night. You will need bipartisan teams to close and seal each ballot drop box right at the close of polls (or as the statute in your state provides). Many jurisdictions recruit staff from sister agencies, since drop box closing teams do not require full poll worker training. Remember, these ballot retrieval teams will need to be bipartisan, even those staff recruited from other agencies, and may need to be sworn in as election workers.

As mentioned in the overview, accommodations for COVID-19 and the need for social distancing will affect your staffing decisions. Asking two unrelated workers to drive together in the same car may be a challenge. You will need to accommodate any retrieval team member requests to travel in separate cars in tandem. The steps for setup and the daily retrieval of ballots should also follow the six-foot distancing requirements.

Voter Outreach and Communication

Promoting the use and availability of ballot drop boxes is essential to their success. Use all of the communication tools and resources at your disposal as soon as practical to publicize ballot drop box locations, hours and notable accessibility features.

For example, use your regular print and electronic materials, website, social media, video, and news releases to announce ballot drop box locations and share a link to a comprehensive list and/or map of ballot drop boxes.

You can also include a list of ballot drop-off locations in your **mail ballot instructions**, **voter information guide** and **sample ballot publications**. Depending on how many locations you have, you may be able to print them on the mail ballot envelope as well. If there are too many locations to fit, perhaps include a link or QR code on the envelope to direct voters to your list of locations.

Your election website will be the optimal resource for voters to find a ballot drop-off location. Create a **web page for Ballot Drop-Off Locations**. Include a list of all location names, addresses, hours and embed a link to a Google map for each. If there is a change to the ballot drop box plan, it should be noted on your official website within 24 hours.

You can also create and embed a **map of all ballot box locations** using Google My Maps. First, create a list of locations as a .csv file, with separate columns for location name, address, city, state and zip code, hours, and type of ballot drop box. Then visit www.google.com/mymaps and follow instructions to import the map. You'll need to create a Google account if you don't already have one.

Issue a **news release and photos** if you have installed one or more new 24-hour ballot drop boxes in your community. Share it with your own employee news channels, local news media, as well as jurisdictions for newsletters and public television news shows.

Ask the clerk or communications team in your local cities and towns if you can submit a **contributed article** for their newsletter, blog or website regarding the election. Be sure to request a deadline and word count. Describe options for voters and indicate where citizens within your jurisdiction can find their nearest ballot drop box and polling place. You can also ask them to embed your election page link on their own webpages.

Another creative idea is to develop a **'Find My Nearest' web-based tool** to help voters find the ballot drop box that is closest to them. A user will type in an address or allow the tool to use their device's 'location services' to identify their current location. The tool would then populate with a map and list of the nearest three or four ballot drop off locations. This will require knowledge of ArcGIS or Google Maps, and will likely require support from your IT department to create.

Execution

Opening and Setup

Whether you are setting up a temporary ballot drop box or a 24-hour location, you will need to plan for a ballot retrieval team to set up, open, and secure the drop boxes for voters to deposit their voted ballots.

Temporary Ballot Drop Boxes

Supplies:

- Locked and sealed ballot drop boxes or bags
- Tamper-evident seals (if replacements are needed)
- Chain of custody logs
- Phone numbers to call for support/emergencies
- Cable or bike lock
- Applicable signage
- Tables and chairs (if necessary)
- "I Voted" stickers (optional)
- Voter information sheet (optional)
- Voter Registration forms (optional)

Voter information sheets, "I Voted" stickers, and other voting related information may be placed near the drop box.

Drive-Through Ballot Drop Boxes

Drive-through ballot drop boxes might be set up in a parking lot or on the street depending on the location. For all street-related setups, there should be a law enforcement officer present to guide the setup and maintain safety throughout the day.

When setting up in a parking lot, consider the use of “no parking” signs. These signs can be left out overnight to ensure no vehicles park in the area to be used for the drive-through location.

Supplies should be delivered, including:

- Locked and sealed ballot drop boxes or bags
- Tamper-evident seals
- Chain of custody logs
- Phone numbers to call for support/emergencies
- Set-up maps/documentation
- Pop-up tent
- Road signs
- Orange cones
- Table and chairs
- “I Voted” stickers (optional)
- Propane heater (optional during cold weather months)
- Flashlights or lanterns

Bipartisan teams should:

1. Position road signs and cones according to provided map or instructions.
2. Set up the tent and position according to the provided map or instructions.
3. Set up the folding table and chairs.
4. Place the ballot drop box on the table.
5. Set up the heater and propane tank if needed

24-Hour Ballot Drop Boxes

Permanent, 24-hour drop boxes should be available for voters to use as soon as ballots are mailed. This requires staff or ballot retrieval teams to inspect, clean, and open the ballot drop slot on each drop box. An assigned route for opening should be created along with a checklist or log to ensure all ballot drop boxes have been opened.

Each retrieval team will need:

- Slot key
- Access door key
- Phone numbers to call for support/emergencies
- Cleaning supplies
- Silicone spray (for locks)
- Flashlight
- Inspection checklist or chain of custody form

For setup and opening of 24-hour ballot drop boxes, retrieval teams will:

1 Unlock	<input type="checkbox"/> Open the ballot slot, using the slot key. <input type="checkbox"/> Open the access door, using the access door key.
2 Inspect and Clean	<input type="checkbox"/> Visually inspect the drop box and surrounding areas. <input type="checkbox"/> If there is any graffiti or wrap damage, the retrieval team will clean or repair as best they can. <i>If unable to clean or repair it thoroughly, use mobile phone to take pictures and note the damage on the chain of custody form</i> <input type="checkbox"/> Wipe down the exterior, top and slot area of the drop box. <input type="checkbox"/> Spray the locks with silicone spray and ensure they can be easily locked and unlocked. <input type="checkbox"/> Both retrieval team members visually inspect the drop box interior for ballots or any type of debris. <input type="checkbox"/> Use a mobile phone to take a picture as time-stamped proof the ballot drop box is empty.
3 Seal and Record	<input type="checkbox"/> Close and lock the access door using the access door key. <input type="checkbox"/> Place a security seal on the access door and record seal number on a chain of custody form. <input type="checkbox"/> Complete and sign the retrieval form or chain of custody form.

Daily Collection of Ballot Drop Boxes

- Only designated bipartisan ballot retrieval teams should remove ballots from drop boxes. This is done in teams of two.
- All designated ballot retrieval team members should wear badges or vests that readily identify them as designated ballot retrievers or election officials.
- Each team of two will be provided a route each day.
- Ballots must be picked up in designated order.
- A separate chain of custody form should be completed at every stop (both for 24-hour drop boxes and temporary drop boxes or bags).
- The ballot retrieval log and checklist should be completed at the beginning of the route, at each stop, and after returning to the election office.
- Visually inspect the drop box and surrounding area at each visit. If there are any signs of tampering or vandalism, take pictures, clean or repair the drop box as best you can, and report in the notes section of the chain of custody form.

















Instructions for Completing Ballot Retrieval Log

- On the front, record the date and time and check off all supplies that have been retrieved.
- On the back, record the route number, date, and names of both ballot retrievers.
- After ballots have been retrieved at each stop, record:
 - Column A: Name/ID/location of the ballot drop box
 - Column B: Seal number on the door (24-hour drop box) when you arrived (should be affixed to custody log) or the security seal on the temporary drop box you are retrieving
 - Column C: Seal number attached to each transfer box or bag (only for 24-hour drop box)
 - Column D: New seal number put on the door (24-hour drop box) or the seal number for the replacement temporary box or bag
 - Column E: Current time of day
 - Column F: Initials of each ballot retrieval team member.

- At the conclusion of each route, the bottom portion of the form should be completed. Consider using the same visual checklist of supplies to indicate all supplies and equipment have been returned to the election office.

Ballot Retrieval Team Daily Log *(front)*

Date: _____ Route Departure Time: _____ : _____ AM PM

 <p><input type="checkbox"/> Access door or padlock keys</p>	 <p><input type="checkbox"/> Empty, portable ballot box(es)</p>	 <p><input type="checkbox"/> Flashlight</p>	 <p><input type="checkbox"/> High-visibility vests</p>
 <p><input type="checkbox"/> Cleaning supplies</p>	 <p><input type="checkbox"/> Gloves</p>	 <p><input type="checkbox"/> Masks</p>	 <p><input type="checkbox"/> Hand sanitizer</p>
 <p><input type="checkbox"/> Chain of custody logs</p>	 <p><input type="checkbox"/> Driving route and map</p>	 <p><input type="checkbox"/> Pens</p>	 <p><input type="checkbox"/> Vehicle keys</p>
 <p><input type="checkbox"/> Clipboard</p>	 <p><input type="checkbox"/> 24-hour drop box security seals</p>	 <p><input type="checkbox"/> Transfer ballot box or bag security seals</p>	 <p><input type="checkbox"/> Mobile phone and charger</p>
<p>Route Return Time: _____ : _____ <input type="checkbox"/> AM <input type="checkbox"/> PM <input type="checkbox"/> Supplies <input type="checkbox"/> Vehicle Keys</p>			

Ballot Retrieval Team Daily Log (back)

Route ID# _____

Date: _____		Retriever 1: _____		Retriever 2: _____	
A	B	C	D	E	F
Drop Box Name/ID	Existing Seal ID	Transfer Box/Bag Seal	New Seal ID	Collection Time	Team Initials

Ballot Retrieval Team Chain of Custody Record

Ballot Drop Box Name/#:	Date:
Retrieval Team Member 1:	Retrieval Team Member 2:
Transfer Box/ Bag #:	Additional Transfer Box/Bag #:

Time of Arrival: <input type="checkbox"/> AM <input type="checkbox"/> PM	Initials:	PLACE USED SECURITY SEAL
Security Seal Intact: <input type="checkbox"/> YES <input type="checkbox"/> NO	Initials:	
Remove security seal and record seal #:		

- Inspect ballot drop box for any signs of tampering or vandalism.
- Unlock the access door and remove ballots.
- Transfer ballots to ballot transfer box or bag.
- Inspect inside of drop box for ballots that might be leaning against or stuck to the wall.
- Inspect drop box area to ensure no ballots have fallen on the ground.
- Seal the ballot transfer box or bag.
- Record the transfer box or bag seal number(s).

Seal #: _____	Seal #: _____
Seal #: _____	Seal #: _____
- Verify access door is closed and locked (checked by both team members).
- Place new security seal on door.
- Record new security seal placed on door:** Seal #: _____
- Load transfer containers into vehicle.
- Record new door security seal and transfer security seal numbers on the ballot retrieval log.

All procedures completed and recorded: <input type="checkbox"/> YES <input type="checkbox"/> NO	Initials:
Service Required? <input type="checkbox"/> YES <input type="checkbox"/> NO	Notes:
Time of Departure: <input type="checkbox"/> AM <input type="checkbox"/> PM	Initials:

Election Night Closing

All ballot drop boxes, temporary and permanent, need to be collected or closed at the time the polls close. The process outlined below is focused on permanent, 24-hour drop boxes, but the same general principles can be applied to temporary ballot drop boxes. These instructions can be supplemented with the Election Night Closing Checklist that follows.

Station a bipartisan retrieval team at each drop box 15 minutes before the polls close. They will lock drop boxes as soon as the polls close and retrieve ballots.

- Consider asking other jurisdictions' employees to assist, since this process does not require a great deal of training. Provide each retrieval team with the necessary supplies and checklist as detailed in this guide. In addition to those supplies, these retrieval teams will also need the following:
 - Map with driving directions and approximate time it will take to arrive at their location. This ensures they leave the election facility with enough time to arrive 15 minutes before the close of the election.
 - "Last Voter in Line" card
 - Extra transfer ballot box or bag to collect ballots cast after the polls close. These ballots will not be counted. These are ballots from voters not in line at the time polls close, but who approach the box as the retrieval team is transferring ballots.
 - Checklist with instructions for completing a full sweep of the drop box with a flashlight along with instructions for locking, sealing, recording, transferring ballots to a temporary box, taking a photo and returning to HQ.
- You may have a line of people, or cars, at close of polls with people waiting to cast their ballot in the drop box. As with in-person voting, have one person walk to the end of the line of people and/or cars and hand the last voter in line at close of polls the "Last Voter In Line" card to ensure everyone in line at close of polls may cast their ballot.
- Instructions for how to handle a line of cars (if 24-hour drop box or drive-through ballot drop-off) or a line of people (if temporary indoor drop box). This should include a "Last Voter in Line" card and potentially coordinating with local law enforcement for traffic control.

- Recommend teams take pictures of:
 - Locked ballot slot
 - Inside of the 24-hour boxes once emptied after the close of polls to show that no ballots are left in the box.

It is highly recommended to have your daily ballot retrieval team visit all ballot drop boxes the day after the election to double-check that all ballots were collected.

Election Night Closing Checklist

Ballot Drop Box Name/#:	Date:
Retrieval Team Member 1:	Retrieval Team Member 2:

- Ensure you have necessary supplies and chain of custody logs before leaving for your designated drop box.
- Ensure you take enough transfer boxes or bags to completely empty the drop box.
- Arrive at your assigned ballot drop box at least 15 minutes early.
- If there is a line before polls close, one retrieval team member must find the "Last Voter In Line" card and go to the end of the line.
- At the close of polls, announce "Polls are closed" and lock the door to the drop box. If there is a line, the team member at the end of the line should give the Last Voter In Line card to the last person or car in line at the close of polls. Once the card is given out, return immediately to help empty the drop box.
- If any voter should try and cast their ballot after the close of polls, put their ballot in the box/bag designated for late ballots.
- Unlock the access door and remove all ballots, placing them in a transfer box or bag.
- Using a flashlight, inspect the inside of the drop box for ballots that might be leaning against or stuck to the wall.
- Once all ballots are removed from the drop box, take a picture of the inside of the empty drop box using your phone.
- Inspect the drop box area to ensure no ballots have fallen on the ground.
- Seal the ballot transfer box(es)/bag(s).
- Verify the access door of the drop box is closed and locked.
- Close the ballot slot using the slot key.
- Complete Chain of Custody log(s) for the transfer box(es) or bag(s).
- Load transfer containers and all supplies into vehicle.
- Head directly back to counting facility.

All procedures completed and recorded:	<input type="checkbox"/> YES <input type="checkbox"/> NO	Initials:
Time of Departure:	<input type="checkbox"/> AM <input type="checkbox"/> PM	Initials:

Common Mistakes and How to Prevent Them

Problem: Drop boxes left unsealed or unlocked

Solution: Checklist that is signed or initialed for each drop box and verified at the end of every shift

Problem: 24-hour drop boxes left open or unlocked

Solution: Checklist that is signed or initialed for each drop box and verified at the end of every shift

Problem: Drop boxes are full before Election Day and voters are leaving ballots on top, calling news media, etc.

Solution: Increase the number of pickup times as you get closer to Election Day

Problem: Drop boxes not closed at 7 p.m.

Solution: Send retrieval teams out to sweep boxes the day after the election to ensure no ballots are left behind (perhaps take photos)

Appendix A: Drop Box Vendors

This list was compiled by the Center for Tech and Civic Life.

Laserfab, Inc/Vote Armor

www.laserfabusa.com

Models:

- VA-3630 is the most popular
- The largest model, the VA-5038, is used by larger counties
- A third model exists, but no model number was provided

Approximate pricing: The 3630 model runs in between \$3000 and \$3500, depending on quantity.

Timeline: 6-8 weeks from order

American Security Cabinets

www.ballotdrops.com

Models:

- 7 different sizes and styles: <https://ballotdrops.com/product-category/cabinets/>

Approximate pricing: Please inquire

Timeline: Please inquire

Fort Knox Mailbox

www.fortknoxmailbox.com

Models: High Security Mailboxes - Fort Knox Mailbox, LLC.

- 3 different sizes: <https://www.fortknoxmailbox.com/ballot-boxes/>

Approximate pricing: \$1,300 - \$3,000 each, depending on model

Timeline: Please inquire

Inclusion Solutions

www.inclusionsolutions.com/wp-content/uploads/2019/06/IScatalog2019v8.pdf (pages 12-13)

Models:

- Fortress 400 ideal for indoor use, holds 400 ballots
- Fortress 800 ideal for indoor use, holds 800 ballots
- Fortress 1000 can transition to indoor & outdoor, holds 1,000 ballots

Approximate pricing: Fortress 400 is \$130, Fortress 800 is \$209, call for info about Fortress 1000

Timeline: Please inquire

Charnstrom

www.charnstrom.com

Models: Four models of “payment cabinets” and “Mail Collection boxes”, ranging in size.

- Small: \$420 - Commercial/Residential Curbside Mailbox (13”W x 18” D x 20”H)
- Large: \$3,608 - Mail Room/Office Mailing Walk or Drive up Box. Holds “hundreds of envelopes and magazines”. (24”W x 29.5” D x 53” H)

Pricing: \$400 to \$4000

Timeline: Please inquire

Global Industrial

www.globalindustrial.com

Models: Mail & Parcel Drop Boxes

- Drop Box Locker: \$450 - \$1,513 (12”W x 12”D x 16.5”H)
- Supreme Letter Locker: \$475 - \$2,283 (12”W x 23”D x 24-36”H)
- Extra Large Mailbox & Parcel Post Vault: \$883 (19”W x 19”D x 52”H)
- Curbside Courier & Collection Box: \$759 - \$967 (20”W x 26”D x 49”H)

Pricing: \$350 to \$2,300 depending on model

Timeline: UPS Next Day, UPS 2nd Day, UPS or Truck 3-8 days shipping

U. S. Mail Supply

www.USMailSupply.com

Models: Some examples

- Small Versatile Pedestal Hopper Collection Box \$1,175 (17.75" L x 18.75"W x 59" H)
- Courier Drop Box \$780 (20"W x 49"H x 26"D)
- All Weather Sealed Outdoor Collection Box \$1,065 (22-1/4"W x 22-1/4"D x 47"H)

Pricing: Varies, depending on model

Timeline: Please inquire

Appendix B: Site Feasibility Planner

See following pages.



Ballot Dropoff Location Planner: Site Feasibility

This document is based on a report by King County, Washington. It can be found here:
<https://kingcounty.gov/~media/depts/elections/about-us/reports/bdol-expansion-plan.ashx?la=en>.

This planning tool can help you study, plan, and justify ballot dropoff locations in your jurisdiction. While the scoring and criteria can be adjusted to specifically fit your jurisdiction’s needs, this document outlines a number of major considerations for planning your dropoff locations and provides some outlines for a scoring rubric.

Proposed Location:

Criteria	Score	Description	Your score & notes
Equity			
Serves isolated communities Does the location serve a geographically isolated area or serve a particular, culturally distinct community?	10	This site serves an isolated or distinct community	
	0	Site does not serve an isolated or distinct community.	
Provide equitable services Does the location sit in a community with demographic characteristics that warrant considerations? (e.g. displaced voters, hard to reach voters, voters w/disabilities, language barriers)	0-10	Note: You may need develop your own scoring criteria based on your jurisdictions.	

Disparities in voter participation Is the site located in an area that has lower than average voter registration rates?	8	Adjacent to census tract with lower than average voter registration rates.	
	4	Lower than average voter participation rates.	
	0	Average or higher than average voter registration rates.	
Operations			
Pick-up and box closing Does the site support an effective, safe and secure ballot pick-up and box closing process? Examples: stairs or inclines to/from, potential to place location in close proximity to parking, etc.	10	Site conditions present no challenges to the daily ballot pick-up or box closing process.	
	5	Site conditions may present a challenge to the daily ballot pick-up or closing process but can be mitigated.	
	0	Site conditions do not support an effective daily ballot pick-up or box closing process.	
Security Is the location monitored live or by video surveillance? If outside, is the location well lit at night?	5	The location is monitored live or by video surveillance and is well lit.	
	2.5	The location has nearby surveillance and is lit.	
	0	The location has no security measures and is not lit at night.	
Site owner input	5	There are no site owner concerns	



<p>Are there site owner concerns regarding increased traffic flow that would negatively affect existing site tenant(s)? Are there known or planned construction projects on site (or near) that might impact the accessibility or feasibility of the site?</p>	2.5	There are site owner concerns that can be mitigated	
	0	Site owner concerns or site conditions do not support an effective ballot drop-off location.	
<p>Drive-up option</p> <p>Do site conditions support both walk-up and drive-up ballot deposit options for voters? Drive-up options offer more convenience to voters.</p>	5	Site conditions, as they presently exist, can support a drive-up option.	
	2.5	Site conditions could support a drive-up option but might impact host property.	
	0	Site conditions do not support a drive-up option.	
<p>End-of-line</p> <p>Does the site support effective control of traffic (both vehicular and pedestrian) to establish "on-time" and "end-of line" status at the voting deadline? Examples: size of the usable area adjacent to the box (to establish orderly queuing), the ability to limit the number of clear paths to the box.</p>	5	Site conditions present no challenges to establishing end-of-line status.	
	2.5	Site conditions present some challenges to establishing end-of-line status	
	0	Site conditions do not support an effective end-of-line establishment process.	
<p>Accessibility</p>			

Visibility Does the site allow for placement of a box that is readily visible and easy to locate by voters? Conditions include: lighting, a clear line of sight from street and/or parking	5	Voters can easily locate the box on site; is fully visible from multiple directions.
	2.5	Some voters may be challenged to find the box without extra signage or lighting.
	0	There may be challenges in finding the box on site due to placement or visibility.
Access to Public Transit Can voters visit the location via public transit? Conditions evaluated include: the number of modes of public transit available at the site and distance from public transit stops/stations.	5	Served by multiple bus lines or modes of public transit; transit stops within 1000 ft
	2.5	Served by one bus line or mode of public transit or stop/station is >1000 ft away.
	0	The site is not served by public transit.
Parking Does the site possess adequate parking for voters? Example: number of parking spots, dedicated parking vs shared parking spots, distance from parking to box and off-street parking in dense locations.	5	Adequate parking option.
	2.5	One or more challenge(s) to parking (< 20 parking spots, limited load/unload options, distance to box exceeds 100ft).
	0	Inadequate parking (pay parking, no load/unload, distance to box exceeds 200ft).



ADA factors Does the site possess all accessible features possible? Conditions evaluated include: parking lot slope, turning radius adjacent to box placement, curb cuts, number of ADA parking spots, unimpeded path to box from ADA parking.	5	Site conditions support 100% accessibility.	
	2.5	Adequate with some mitigation.	
	0	Site does not support accessibility.	
Continuity			
Location History Does the location have a history of serving as a voting location (in-person or drop box)?	10	Site has previously served as a voting location.	
	0	All other sites.	

Final Score:



Deanna Debruler

From: Michael Spitzer-Rubenstein <michael@voteathome.org>
Sent: Tuesday, September 8, 2020 11:53 AM
Subject: Learn about Vote at Home's Operational Planning Tools

Hi all,

I wanted to let you know that we're hosting a demo of the [operations tools](#) for election officials next week. It'll be a great introduction on how to estimate election inspector needs, polling place wait times, and a chance to ask questions. The demo is tomorrow, Wed Sept 9th, 3-4pm ET and you can [register here](#).

In addition, if you discover that you need additional resources, we have funding available, both from ourselves, and the [Center for Tech and Civic Life](#) (thanks to Priscilla Chan and Mark Zuckerberg). We can also connect you to partners like [Power the Polls](#) if you need to recruit poll workers or facilities.

I hope you'll join us and I'm also happy to set up a follow-up meeting to discuss how we can further assist your jurisdiction.

Thank you,
Michael Spitzer-Rubenstein

--

Michael Spitzer-Rubenstein
State Lead for Wisconsin (Leadership Now Fellow)
National Vote at Home Institute

([REDACTED]

he/him



Deanna Debruler

From: Eric Genrich
Sent: Thursday, June 18, 2020 10:16 AM
To: Celestine Jeffreys; Kris Teske; Diana Ellenbecker
Subject: RE: meeting continues

Kris and I have a conflicting meeting...

From: Celestine Jeffreys
Sent: Thursday, June 18, 2020 10:14 AM
To: Eric Genrich; Kris Teske; Diana Ellenbecker
Subject: meeting continues
When: Thursday, June 18, 2020 10:01 AM-11:01 AM.
Where: [REDACTED]

Celestine Jeffreys is inviting you to a scheduled Zoom meeting.

Join Zoom Meeting

[REDACTED]

Meeting ID: [REDACTED]
Password: [REDACTED]
One tap mobile
+13017158592,,88327557531#,,,,0#,,989112# US (Germantown)
+13126266799,,88327557531#,,,,0#,,989112# US (Chicago)

Dial by your location
+1 301 715 8592 US (Germantown)
+1 312 626 6799 US (Chicago)
+1 929 205 6099 US (New York)
+1 253 215 8782 US (Tacoma)
+1 346 248 7799 US (Houston)
+1 669 900 6833 US (San Jose)

Meeting ID: [REDACTED]
Password: [REDACTED]
Find your local number: <https://us02web.zoom.us/j/kdc2uEW3Xx>

Deanna Debruler

From: Celestine Jeffreys
Sent: Wednesday, May 27, 2020 11:19 AM
To: Kris Teske
Subject: RE: Meeting Minutes for Ad Hoc

Thanks, Kris, I appreciate that!

Celestine Jeffreys
Chief of Staff, Mayor's Office
City of Green Bay

From: Kris Teske
Sent: Wednesday, May 27, 2020 10:04 AM
To: Celestine Jeffreys <Celestine.Jeffreys@greenbaywi.gov>
Subject: RE: Meeting Minutes for Ad Hoc

Got it! I will let her know for the future. Thanks

Kris Teske, WCMC
Green Bay City Clerk
100 N. Jefferson St., Rm 106
Green Bay, WI 54301
920-448-3014



From: Celestine Jeffreys
Sent: Wednesday, May 27, 2020 9:40 AM
To: Kris Teske <Kris.Teske@greenbaywi.gov>
Subject: RE: Meeting Minutes for Ad Hoc

Hey, Kris!

I understand, but we have a miscommunication. When I'm the meeting manager, I make notes in the box on civic clerk so I can go back and put the motions in properly. I also do the votes right then and there.

It will be difficult for me to participate and record at the same time. I would suggest that Kim just take note of the motions and the votes, either in civic clerk or on a separate piece of paper, and I can take it from there.

Celestine Jeffreys
Chief of Staff, Mayor's Office
City of Green Bay

From: Kris Teske
Sent: Wednesday, May 27, 2020 9:03 AM

Deanna Debruler

From: Celestine Jeffreys
Sent: Tuesday, September 8, 2020 10:40 PM
To: 'Whitney May'
Subject: RE: Mikva Challenge: Recruiting HS students to serve as poll workers

Frank from the Mikva project got back to me with some spiffy resources. Thanks for the connection!

Celestine Jeffreys
Chief of Staff, Mayor's Office
City of Green Bay

From: Whitney May <whitney@techandcivicliflife.org>
Sent: Thursday, September 3, 2020 8:30 PM
To: Celestine Jeffreys <Celestine.Jeffreys@greenbaywi.gov>
Subject: Mikva Challenge: Recruiting HS students to serve as poll workers

Hey Celestine,

Great chatting with you today. I bumped Ashish on the dropbox delivery and let him know to expect a call from you.

Regarding recruitment of HS poll workers. I reached out to Meghan at Mikva challenge and asked for 1-pagers and messaging they've used. Will let you know what I hear back.

Meanwhile, if you're interested, there's this ~5 minute section of video where Meghan talks about how they recruit HS student election judges in Chicago.

Jump to the 11:30ish mark in the video.

<https://vimeo.com/432919914/67d223baa8>

Stay safe,
Whitney M

--

Whitney May
Director of Government Services
Center for Tech and Civic Life
whitney@techandcivicliflife.org
(919) 799-6173
she/her

Deanna Debruler

From: Whitney May <whitney@techandcivicliflife.org>
Sent: Friday, September 4, 2020 9:35 AM
To: Celestine Jeffreys
Subject: Re: Mikva Challenge: Recruiting HS students to serve as poll workers

Great!

And here's the page on the Madison Clerk's site about student officials: <https://www.cityofmadison.com/clerk/elections-voting/election-officials/student-officials>

On Fri, Sep 4, 2020 at 9:15 AM Celestine Jeffreys <Celestine.Jeffreys@greenbaywi.gov> wrote:
Whitney,

The website looks intriguing! A way for us to carry forward the work we're doing for this November election.
Megan's email is on the website, so I'll reach out.

Thanks!

From: Whitney May <whitney@techandcivicliflife.org>
Sent: Thursday, September 3, 2020 8:31 PM
To: Celestine Jeffreys <Celestine.Jeffreys@greenbaywi.gov>
Subject: Re: Mikva Challenge: Recruiting HS students to serve as poll workers

Ps. Here's the link to Mikva Challenge if that's helpful context: <https://mikvachallenge.org/our-work/programs/elections-and-campaign-experiences/>

On Thu, Sep 3, 2020 at 8:30 PM Whitney May <whitney@techandcivicliflife.org> wrote:
Hey Celestine,

Great chatting with you today. I bumped Ashish on the dropbox delivery and let him know to expect a call from you.

Regarding recruitment of HS poll workers. I reached out to Meghan at Mikva challenge and asked for 1-pagers and messaging they've used. Will let you know what I hear back.

Meanwhile, if you're interested, there's this ~5 minute section of video where Meghan talks about how they recruit HS student election judges in Chicago.

Jump to the 11:30ish mark in the video.

<https://vimeo.com/432919914/67d223baa8>

Stay safe,
Whitney M

Deanna Debruler

From: Celestine Jeffreys
Sent: Friday, September 4, 2020 10:59 AM
To: meghan@mikvachallenge.org
Cc: Whitney May; Kris Teske
Subject: Referred by Whitney May, Center for Tech and Civic Life

Dear Ms. Goldstein,

I'm Celestine Jeffreys, the Chief of Staff here in Green Bay Wisconsin. I was referred by Whitney May, who's working with us courtesy of a grant we won from the Center for Tech and Civic Life.

I know you're very busy. Can you share a document or two that you've created to help recruit high school and college students to become poll workers?

I appreciate anything you'd be willing to provide.

Have a wonderful Labor Day weekend!

Celestine Jeffreys



Celestine Jeffreys

Chief of Staff
Office of the Mayor
920.448.3006

Deanna Debruler

From: Celestine Jeffreys
Sent: Wednesday, September 16, 2020 2:59 PM
To: Ari Steinberg
Cc: Priya Garg; Tom Malloy; Robin Carnahan; Kris Teske; Whitney May
Subject: RE: Email address for the election

Ari, et al,

I appreciate your time and attention. I need to get this document completed, while "clerk@" isn't very descriptive, I will use it.

In the future, I can amend the document to reflect a more descriptive address.

Celestine Jeffreys
Chief of Staff, Mayor's Office
City of Green Bay

From: Ari Steinberg <ari@usdigitalresponse.org>
Sent: Wednesday, September 16, 2020 2:47 PM
To: Celestine Jeffreys <Celestine.Jeffreys@greenbaywi.gov>
Cc: Priya Garg <priya@usdigitalresponse.org>; Tom Malloy <thomasjmalloy@kttk.org>; Robin Carnahan <robin@usdigitalresponse.org>; Kris Teske <Kris.Teske@greenbaywi.gov>; Whitney May <whitney@techandcivillife.org>
Subject: Re: Email address for the election

Thanks Celestine, I now realize you probably were asking whether the address "clerk@" was descriptive enough (vs another address such as, maybe, "voting@"). Sorry that I misunderstood you the previous time around!

That's a totally fair point - we could certainly set up another address and have it all tie into the same inbox. Again, this is ultimately up to what you all would like to do. At a technical level, setting up another alias should be fairly easy to do for your IT dept and it would have no impact on the workflows for Kris and team so it's mostly an editorial judgment.

We had initially picked clerk@ because we do need a single address for the office that could capture all clerk-related questions, but we could additionally set up dedicated addresses by topic (e.g. maybe voting@, licensing@, etc.) All the messages could appear in one system but using separate addresses by topic has the upside of allowing us to pre-sort the messages based on which address is used, so I do like the suggestion!

Kris, what do you think? Should we ask Mike to get this set up?

On Wed, Sep 16, 2020 at 12:36 PM Celestine Jeffreys <Celestine.Jeffreys@greenbaywi.gov> wrote:

Ari,

Thank you for the response. I see you've really tried to explore many scenarios.

Given your efforts and in the interest of time, I'll go ahead and use clerk@greenbaywi.gov. However, that address does not convey "voting assistance."

Celestine Jeffreys

Chief of Staff, Mayor's Office

City of Green Bay

From: Ari Steinberg <ari@usdigitalresponse.org>

Sent: Wednesday, September 16, 2020 2:05 PM

To: Celestine Jeffreys <Celestine.Jeffreys@greenbaywi.gov>

Cc: Priya Garg <priya@usdigitalresponse.org>; Tom Malloy <thomasjmalloy@kttk.org>; Robin Carnahan <robin@usdigitalresponse.org>; Kris Teske <Kris.Teske@greenbaywi.gov>; Whitney May <whitney@techandciviclelife.org>

Subject: Re: Email address for the election

Great question. Currently, clerk@ is set up to land in the shared "Front" inbox which makes it easier for Kris' team to share/coordinate the work of responding across multiple people.

We have NOT set up any kind of auto-responder to clerk@ but that is definitely an option. E.g. it could say something like, "Thanks for your email, it may take us a few days to respond. In the meantime, please visit [our website](#) for answers to common questions." The downside of this is that if they do find an answer to their question, we would not know about it and someone from the clerk's office will still wind up spending time trying to help them. But this is very easy to do and probably pretty harmless.

If we want to get *really* aggressive with reducing email load, we can have clerk@ set up to send an autoresponse saying something like, "IMPORTANT: This mailbox is not monitored, please visit [our website](#) where you can get answers to common questions or submit messages to the Green Bay Clerk's Office." and then have it NOT create a ticket in the Front system. Someone would need to read this autoresponse, click through to the web site, and fill out the contact form that we are helping to build on that site. This would be the most effective option from the standpoint of reducing your workload though it also might be perceived as less voter-friendly.

On Wed, Sep 16, 2020 at 9:39 AM Celestine Jeffreys <Celestine.Jeffreys@greenbaywi.gov> wrote:

Ari,

Thanks for the answer.

Let me ask a follow-up question. If voters are trying to remember how to get help, does clerk@greenbaywi.gov convey that message?

Celestine Jeffreys

Chief of Staff, Mayor's Office

City of Green Bay

From: Ari Steinberg <ari@usdigitalresponse.org>
Sent: Wednesday, September 16, 2020 11:16 AM
To: Celestine Jeffreys <Celestine.Jeffreys@greenbaywi.gov>
Cc: Priya Garg <priya@usdigitalresponse.org>; Tom Malloy <thomasjmalloy@kttk.org>; Robin Carnahan <robin@usdigitalresponse.org>; Kris Teske <Kris.Teske@greenbaywi.gov>; Whitney May <whitney@techandciviclelife.org>
Subject: Re: Email address for the election

Hi Celestine, I believe that Kris and team had landed on clerk@greenbaywi.gov but will defer to them for the final confirmation!

Thanks.

Ari

On Tue, Sep 15, 2020 at 5:08 PM Celestine Jeffreys <Celestine.Jeffreys@greenbaywi.gov> wrote:

Good evening!

I understand that the US Digital Response team is crafting an email address that will be easy for voters to remember and will be pointed to city hall staff and voter navigators.

We need to finalize a document, and I would like to know what that address is so I can publish.

Can you provide this by Thursday morning?

Thank you!

Celestine Jeffreys

Chief of Staff, Mayor's Office

City of Green Bay

Deanna Debruler

From: Whitney May <whitney@techandcivicliflife.org>
Sent: Monday, August 17, 2020 7:09 PM
To: Celestine Jeffreys; Kris Teske
Cc: Erika Reinhardt; Robin Carnahan; Elections/Voting Team; Priya Garg
Subject: Green Bay, WI + U.S. Digital Response: Poll worker management technology
Attachments: USDR — Poll Worker Offering.pdf

Hi Celestine and Kris,

I'm connecting you with Erika, Robin and the elections team from U.S. Digital Response. They can provide your office free technology to help streamline the hiring, onboarding, and management of Green Bay poll workers. I attached a PDF document that describes the offering.

Hi Erika, Robin, and the USDR elections team,

Celestine is the Green Bay Mayor's Chief of Staff. Kris is the Green Bay Clerk. They've expressed an interest in learning more about your poll worker technology and how they might deploy it this year.

I hope you can find time to talk soon. And I'll let y'all take it from here.

Stay safe,
Whitney M

--

Whitney May
Director of Government Services
Center for Tech and Civic Life
whitney@techandcivicliflife.org
(919) 799-6173
she/her

Deanna Debruler

From: Celestine Jeffreys
Sent: Tuesday, September 8, 2020 12:33 PM
To: 'Whitney May'
Subject: RE: Green Bay, WI + USDR: Ballot curing

Thanks!!

Celestine Jeffreys
Chief of Staff, Mayor's Office
City of Green Bay

From: Whitney May <whitney@techandcivicliflife.org>
Sent: Friday, September 4, 2020 3:41 PM
To: Celestine Jeffreys <Celestine.Jeffreys@greenbaywi.gov>; Kris Teske <Kris.Teske@greenbaywi.gov>
Cc: amber@usdigitalresponse.org; Erika Reinhardt <erika@usdigitalresponse.org>; Ryan Chew <ryan@electionsgroup.com>
Subject: Re: Green Bay, WI + USDR: Ballot curing

Adding Ryan from Elections Group here, too. He's cc'd.

Hope you can find a time to all connect and discuss the ballot curing process in Green Bay.

On Fri, Sep 4, 2020 at 8:46 AM Whitney May <whitney@techandcivicliflife.org> wrote:

Hi Celestine and Kris,

Thanks for taking time to talk with me yesterday. To follow up on our brief conversation about absentee ballot curing, I'm connecting you with Erika and Amber from USDR (both cc'd).

Amber is exploring ways to streamline the curing process and is interested in connecting with you to learn more about your process in Green Bay.

I hope you can find time to talk soon. And I'll let y'all take it from here.

TGIF,
Whitney

--
Whitney May
Director of Government Services
Center for Tech and Civic Life
whitney@techandcivicliflife.org
(919) 799-6173
she/her

--

Whitney May

Director of Government Services

Center for Tech and Civic Life

whitney@techandciviclife.org

(919) 799-6173

she/her

Deanna Debruler

From: Erika Reinhardt <erika@usdigitalresponse.org>
Sent: Friday, September 4, 2020 6:07 PM
To: Whitney May
Cc: Celestine Jeffreys; Kris Teske; Amber Feng; Ryan Chew
Subject: Re: Green Bay, WI + USDR: Ballot curing

Hi Kris,

We heard from Whitney that ballot cures are currently a very manual process for you, and that you might be interested in help streamlining and automating that process. We're happy to chat anytime next week that you're free to get started, but I know that you're also already working with us on poll workers and support tools, so if you have your hands full at the moment and are only ready to pick this one up a bit later, just let us know when's good for you! We'll do all we can to keep the needs on you and your office as low as possible.

Cheers,
Erika

On Fri, Sep 4, 2020 at 1:41 PM Whitney May <whitney@techandciviclife.org> wrote:
Adding Ryan from Elections Group here, too. He's cc'd.

Hope you can find a time to all connect and discuss the ballot curing process in Green Bay.

On Fri, Sep 4, 2020 at 8:46 AM Whitney May <whitney@techandciviclife.org> wrote:
Hi Celestine and Kris,

Thanks for taking time to talk with me yesterday. To follow up on our brief conversation about absentee ballot curing, I'm connecting you with Erika and Amber from USDR (both cc'd).

Amber is exploring ways to streamline the curing process and is interested in connecting with you to learn more about your process in Green Bay.

I hope you can find time to talk soon. And I'll let y'all take it from here.

TGIF,
Whitney

--

Whitney May
Director of Government Services
Center for Tech and Civic Life
whitney@techandciviclife.org
(919) 799-6173
she/her

Deanna Debruler

From: Kris Teske
Sent: Friday, September 4, 2020 10:10 AM
To: 'Whitney May'
Subject: RE: Green Bay, WI + USDR: Ballot curing

Thank you!

Kris Teske, WCMC
Green Bay City Clerk
100 N. Jefferson St., Rm 106
Green Bay, WI 54301
920-448-3014



From: Whitney May [mailto:whitney@techandcivillife.org]
Sent: Friday, September 4, 2020 8:47 AM
To: Celestine Jeffreys <Celestine.Jeffreys@greenbaywi.gov>; Kris Teske <Kris.Teske@greenbaywi.gov>
Cc: amber@usdigitalresponse.org; Erika Reinhardt <erika@usdigitalresponse.org>
Subject: Green Bay, WI + USDR: Ballot curing

Hi Celestine and Kris,

Thanks for taking time to talk with me yesterday. To follow up on our brief conversation about absentee ballot curing, I'm connecting you with Erika and Amber from USDR (both cc'd).

Amber is exploring ways to streamline the curing process and is interested in connecting with you to learn more about your process in Green Bay.

I hope you can find time to talk soon. And I'll let y'all take it from here.

TGIF,
Whitney

--

Whitney May
Director of Government Services
Center for Tech and Civic Life
whitney@techandcivillife.org
(919) 799-6173
she/her

Deanna Debruler

From: Celestine Jeffreys
Sent: Saturday, September 12, 2020 6:27 AM
To: 'Michael Spitzer-Rubenstein'
Cc: Eric Ming; 'Whitney May'
Subject: FW: 2020-09-07 How to Make Voting Plan_EDITS_RKL

Follow Up Flag: Follow up
Flag Status: Completed

Michael,

Here's our post. It's not as spiffy as I'd like and doesn't include the checklists. I'm still waiting on information to complete and will re-post next week. In the meantime, we're going to refer voters here.

Celestine Jeffreys
Chief of Staff, Mayor's Office
City of Green Bay

From: Shelby Edlebeck <Shelby.Hearley@greenbaywi.gov>
Sent: Friday, September 11, 2020 2:56 PM
To: Celestine Jeffreys <Celestine.Jeffreys@greenbaywi.gov>
Subject: RE: 2020-09-07 How to Make Voting Plan_EDITS_RKL

Posted! <https://www.facebook.com/GreenBayCity/posts/3852985118052114>

Thank you,
Shelby Edlebeck
920.448.3207

From: Celestine Jeffreys
Sent: Friday, September 11, 2020 1:45 PM
To: Shelby Edlebeck <Shelby.Hearley@greenbaywi.gov>
Subject: 2020-09-07 How to Make Voting Plan_EDITS_RKL

Deanna Debruler

From: Witzel-Behl, Maribeth <MWitzel-Behl@cityofmadison.com>
Sent: Wednesday, August 19, 2020 4:57 PM
To: 'Christopher Patten'; Woodall-Vogg, Claire
Cc: Whitney May; Michelle Nelson; Coolidge, Tara; Celestine Jeffreys; Kris Teske; Josh Goldman; Asher Kolieboi
Subject: RE: Absentee instructions template & envelopes from Center for Civic Design: Feedback requested by Friday

Follow Up Flag: Follow up
Flag Status: Completed

I love it! Thank you very much!

- Maribeth

From: Christopher Patten <christopher@civicdesign.org>
Sent: Wednesday, August 19, 2020 4:50 PM
To: Woodall-Vogg, Claire <cwooda@milwaukee.gov>
Cc: Witzel-Behl, Maribeth <MWitzel-Behl@cityofmadison.com>; Whitney May <whitney@techandciviclife.org>; Michelle Nelson <mnelson@kenosha.org>; Coolidge, Tara <tara.coolidge@cityofracine.org>; Celestine Jeffreys <Celestine.Jeffreys@greenbaywi.gov>; Kris.Teske@greenbaywi.gov; Josh Goldman <josh@techandciviclife.org>; Asher Kolieboi <asher@civicdesign.org>
Subject: Re: Absentee instructions template & envelopes from Center for Civic Design: Feedback requested by Friday

Caution: This email was sent from an external source. Avoid unknown links and attachments.

Hi everyone,

This version of the instructions includes a larger font size and a redesigned image of where to sign on the back of the ballot. Check it out and let us know what you think!

Thanks!

Christopher and Asher

On Wed, Aug 19, 2020 at 1:47 PM Woodall-Vogg, Claire <cwooda@milwaukee.gov> wrote:

I much prefer these from CCD to the ones that were released yesterday. I will admit, this update slipped past me on July 31st when it was approved by the WEC.

I agree with Maribeth about size of font. I like the layout and simplicity a lot, though.

From: Witzel-Behl, Maribeth <MWitzel-Behl@cityofmadison.com>
Sent: Tuesday, August 18, 2020 6:37 PM
To: 'Whitney May' <whitney@techandcivicliflife.org>; Michelle Nelson <mnelson@kenosha.org>; Coolidge, Tara <tara.coolidge@cityofracine.org>; Celestine Jeffreys <Celestine.Jeffreys@greenbaywi.gov>; Woodall-Vogg, Claire <cwooda@milwaukee.gov>; Kris.Teske@greenbaywi.gov
Cc: Josh Goldman <josh@techandcivicliflife.org>; Asher Kolieboi <asher@civicdesign.org>; Christopher Patten <christopher@civicdesign.org>
Subject: RE: Absentee instructions template & envelopes from Center for Civic Design: Feedback requested by Friday

Wow! Thank you!

I like the design. Is it possible to have the text larger in the instructions? I'm wondering how hard it might be for our older voters to read the 9-point font.

Thank you!

- Maribeth

From: Whitney May <whitney@techandcivicliflife.org>
Sent: Tuesday, August 18, 2020 12:07 PM
To: Michelle Nelson <mnelson@kenosha.org>; Coolidge, Tara <tara.coolidge@cityofracine.org>; Celestine Jeffreys <Celestine.Jeffreys@greenbaywi.gov>; Witzel-Behl, Maribeth <MWitzel-Behl@cityofmadison.com>;
cwooda@milwaukee.gov; Kris.Teske@greenbaywi.gov
Cc: Josh Goldman <josh@techandcivicliflife.org>; Asher Kolieboi <asher@civicdesign.org>; Christopher Patten <christopher@civicdesign.org>
Subject: Absentee instructions template & envelopes from Center for Civic Design: Feedback requested by Friday

Caution: This email was sent from an external source. Avoid unknown links and attachments.

Hello Claire, Celestine, Kris, Tara, Michelle, and Maribeth:

You are the famous WI-5. Congrats on successful administration of last week's state primary! Excited to see November be an even bigger success for you and your teams.

With November in mind, I'm cc'ing the designers from Center for Civic Design, Asher & Christopher. CCD is one of the amazing technical assistance partners available to support the WI-5 (we really do need to get WI-5 tshirts).

Since we've heard interest from you about what other cities are doing, we thought it would be helpful to gather feedback on absentee envelopes and instructions from the WI-5 cohort as a group rather than gathering feedback separately.

- Here are the absentee instructions designed by CCD
 - It's a template in a Word doc
 - You can edit and customize for your city
 - Christopher and Asher are available to consult on design
 - Christopher and Asher have designed this by combining CCD's best practices and language from Madison's instructions.

- Here are the absentee envelopes designed by CCD
 - CCD has been working on the design with WEC
 - CCD + Oxide Design are available to consult on design and printing with your printer
 - Consult can look like adjusting the templates, adding your contact and other information, working with your envelope vendors (if needed) as you fit the layouts into your process (including any size or placement adjustments), or just providing any support, advice, or reviews of proofs.

Do you and your teams have capacity to review these materials and provide questions and feedback to CTCL & CCD before the end of the week?

We know you are all working on tight timelines for printing and collating absentee materials. Please let CTCL & CCD know how we can be most helpful moving forward. If it's useful, grant funds are available for cities that want to print new envelopes.

Thank you,
Whitney & Josh from CTCL

--

Whitney May

Director of Government Services

Center for Tech and Civic Life

whitney@techandcivicliflife.org

(919) 799-6173

she/her

The City of Milwaukee is subject to Wisconsin Statutes related to public records. Unless otherwise exempted from the public records law, senders and receivers of City of Milwaukee e-mail should presume that e-mail is subject to release upon request, and is subject to state records retention requirements. See City of Milwaukee full e-mail disclaimer at www.milwaukee.gov/email_disclaimer

--

Christopher Patten
Center for Civic Design
civicdesign.org
313-590-7653 | christopher@civicdesign.org
Pronouns: he/him

Deanna Debruler

From: Whitney May <whitney@techandciviclife.org>
Sent: Tuesday, August 18, 2020 8:41 PM
To: Celestine Jeffreys
Subject: Re: UPDATE: Absentee instructions template & envelopes from Center for Civic Design: No action required

Got it. What time is your meeting with Ryan?

On Tue, Aug 18, 2020 at 8:16 PM Celestine Jeffreys <Celestine.Jeffreys@greenbaywi.gov> wrote:

We're going to talk to Ryan tomorrow about that. Kris' concern is that we wouldn't get those ballots back to the clerk's office by 8 pm.



Celestine Jeffreys

Chief of Staff

Office of the Mayor

920.448.3006

From: Whitney May <whitney@techandciviclife.org>
Sent: Tuesday, August 18, 2020 8:15 PM
To: Celestine Jeffreys <Celestine.Jeffreys@greenbaywi.gov>
Subject: Re: UPDATE: Absentee instructions template & envelopes from Center for Civic Design: No action required

Related: Are y'all planning to have dropboxes at your precincts on Election Day?

On Tue, Aug 18, 2020 at 8:12 PM Celestine Jeffreys <Celestine.Jeffreys@greenbaywi.gov> wrote:

Thanks, I'll convey that to Kris and have her get in touch with the WEC. She also has to ask them (she may have done this already) about some rules for the drop boxes.



Celestine Jeffreys

Chief of Staff

Office of the Mayor

920.448.3006

From: Whitney May <whitney@techandciviclife.org>

Sent: Tuesday, August 18, 2020 8:11 PM

To: Celestine Jeffreys <Celestine.Jeffreys@greenbaywi.gov>

Subject: Re: UPDATE: Absentee instructions template & envelopes from Center for Civic Design: No action required

I don't know for sure, but I assume they want all localities using the same instructions and the same envelopes since they travel together. You and Kris may want to ask WEC directly.

On Tue, Aug 18, 2020 at 8:02 PM Celestine Jeffreys <Celestine.Jeffreys@greenbaywi.gov> wrote:

Just looked at the uniform instructions. I agree with Maribeth in that the font may be too small for some voters, but overall it's less clear and concise than the document CTCL had produced. I liked the clerk's information right up front.

But I have a question, are municipalities going to be required to use this form and no other?



Celestine Jeffreys

Chief of Staff

Office of the Mayor

920.448.3006

From: Whitney May <whitney@techandcivicliflife.org>

Sent: Tuesday, August 18, 2020 7:50 PM

To: Celestine Jeffreys <Celestine.Jeffreys@greenbaywi.gov>

Subject: Re: UPDATE: Absentee instructions template & envelopes from Center for Civic Design: No action required

Hey Celestine,

I'm excited for y'all to get the envelopes next year. It'll be great.

Regarding the instructions sheet, did you get the Uniform Absentee Instructions sheet from WEC today?

It's attached. I'm assuming they want all cities using the same envelopes AND absentee instructions, too.

Let me know what you think.

Whitney M

On Tue, Aug 18, 2020 at 7:43 PM Celestine Jeffreys <Celestine.Jeffreys@greenbaywi.gov> wrote:

Thanks, Whitney!!

I had mocked-up some changes to the insert. Here they are; what do you think? I didn't hear from Kris, she's not feeling well today.

That's too bad about the envelope. Those changes are really good!



Celestine Jeffreys

Chief of Staff

Office of the Mayor

920.448.3006

From: Whitney May <whitney@techandcivicliflife.org>

Sent: Tuesday, August 18, 2020 7:38 PM

To: Witzel-Behl, Maribeth <MWitzel-Behl@cityofmadison.com>

Cc: Michelle Nelson <mnelson@kenosha.org>; Coolidge, Tara <tara.coolidge@cityofracine.org>; Celestine Jeffreys <Celestine.Jeffreys@greenbaywi.gov>; cwooda@milwaukee.gov; Kris Teske <Kris.Teske@greenbaywi.gov>; Josh Goldman <josh@techandcivicliflife.org>; Asher Kolieboi <asher@civicdesign.org>; Christopher Patten <christopher@civicdesign.org>

Subject: UPDATE: Absentee instructions template & envelopes from Center for Civic Design: No action required

Hello everyone,

Thank you for taking time to review the CCD materials and ask questions today.

CTCL is putting the brakes on operation envelope with the WI-5 because:

- WEC wants everyone in the state using the same formats
- WEC wants to complete new envelope design work next year
- WEC shared uniform instructions today

Apologies for any confusion. Please reach out with any questions or concerns. And keep truckin'!

Stay safe out there,

Whitney M

On Tue, Aug 18, 2020 at 6:36 PM Witzel-Behl, Maribeth <MWitzel-Behl@cityofmadison.com> wrote:

Wow! Thank you!

I like the design. Is it possible to have the text larger in the instructions? I'm wondering how hard it might be for our older voters to read the 9-point font.

Thank you!

- Maribeth

From: Whitney May <whitney@techandcivicliflife.org>

Sent: Tuesday, August 18, 2020 12:07 PM

To: Michelle Nelson <mnelson@kenosha.org>; Coolidge, Tara <tara.coolidge@cityofracine.org>;
Celestine Jeffreys <Celestine.Jeffreys@greenbaywi.gov>; Witzel-Behl, Maribeth <MWitzel-Behl@cityofmadison.com>; cwooda@milwaukee.gov; Kris.Teske@greenbaywi.gov

Cc: Josh Goldman <josh@techandcivicliflife.org>; Asher Kolieboi <asher@civicdesign.org>; Christopher Patten <christopher@civicdesign.org>

Subject: Absentee instructions template & envelopes from Center for Civic Design: Feedback requested by Friday

Hello Claire, Celestine, Kris, Tara, Michelle, and Maribeth:

You are the famous WI-5. Congrats on successful administration of last week's state primary! Excited to see November be an even bigger success for you and your teams.

With November in mind, I'm cc'ing the designers from Center for Civic Design, Asher & Christopher. CCD is one of the amazing technical assistance partners available to support the WI-5 (we really do need to get WI-5 tshirts).

Since we've heard interest from you about what other cities are doing, we thought it would be helpful to gather feedback on absentee envelopes and instructions from the WI-5 cohort as a group rather than gathering feedback separately.

- Here are the absentee instructions designed by CCD
 - It's a template in a Word doc
 - You can edit and customize for your city
 - Christopher and Asher are available to consult on design
 - Christopher and Asher have designed this by combining CCD's best practices and language from Madison's instructions.

- Here are the absentee envelopes designed by CCD
 - CCD has been working on the design with WEC
 - CCD + Oxide Design are available to consult on design and printing with your printer
 - Consult can look like adjusting the templates, adding your contact and other information, working with your envelope vendors (if needed) as you fit the layouts into your process (including any size or placement adjustments), or just providing any support, advice, or reviews of proofs.

Do you and your teams have capacity to review these materials and provide questions and feedback to CTCL & CCD before the end of the week?

We know you are all working on tight timelines for printing and collating absentee materials. Please let CTCL & CCD know how we can be most helpful moving forward. If it's useful, grant funds are available for cities that want to print new envelopes.

Thank you,
Whitney & Josh from CTCL

--

Whitney May

Director of Government Services

Center for Tech and Civic Life

whitney@techandcivicliflife.org

(919) 799-6173

she/her

--

Whitney May

Director of Government Services

Center for Tech and Civic Life

whitney@techandcivicliflife.org

(919) 799-6173

she/her

--

Whitney May

Director of Government Services

Center for Tech and Civic Life

whitney@techandcivicliflife.org

(919) 799-6173

she/her

--

Whitney May

Director of Government Services

Center for Tech and Civic Life

whitney@techandcivicliflife.org

(919) 799-6173

she/her

--

Whitney May

Director of Government Services

Center for Tech and Civic Life

whitney@techandcivicliflife.org

(919) 799-6173

she/her

--

Whitney May

Director of Government Services

Center for Tech and Civic Life

whitney@techandcivicliflife.org

(919) 799-6173

she/her

Deanna Debruler

From: Celestine Jeffreys
Sent: Tuesday, August 18, 2020 7:54 PM
To: 'Whitney May'
Subject: RE: UPDATE: Absentee instructions template & envelopes from Center for Civic Design: No action required

No, I must have missed that email.

I'll take a look. I think the envelopes will be a great improvement, but for next year.



Celestine Jeffreys

Chief of Staff
Office of the Mayor
920.448.3006

From: Whitney May <whitney@techandcivicliflife.org>
Sent: Tuesday, August 18, 2020 7:50 PM
To: Celestine Jeffreys <Celestine.Jeffreys@greenbaywi.gov>
Subject: Re: UPDATE: Absentee instructions template & envelopes from Center for Civic Design: No action required

Hey Celestine,

I'm excited for y'all to get the envelopes next year. It'll be great.

Regarding the instructions sheet, did you get the Uniform Absentee Instructions sheet from WEC today?

It's attached. I'm assuming they want all cities using the same envelopes AND absentee instructions, too.

Let me know what you think.

Whitney M

On Tue, Aug 18, 2020 at 7:43 PM Celestine Jeffreys <Celestine.Jeffreys@greenbaywi.gov> wrote:

Thanks, Whitney!!

I had mocked-up some changes to the insert. Here they are; what do you think? I didn't hear from Kris, she's not feeling well today.

That's too bad about the envelope. Those changes are really good!



Celestine Jeffreys

Chief of Staff

Office of the Mayor

920.448.3006

From: Whitney May <whitney@techandcivicliflife.org>

Sent: Tuesday, August 18, 2020 7:38 PM

To: Witzel-Behl, Maribeth <MWitzel-Behl@cityofmadison.com>

Cc: Michelle Nelson <mnelson@kenosha.org>; Coolidge, Tara <tara.coolidge@cityofracine.org>; Celestine Jeffreys <Celestine.Jeffreys@greenbaywi.gov>; cwooda@milwaukee.gov; Kris Teske <Kris.Teske@greenbaywi.gov>; Josh Goldman <josh@techandcivicliflife.org>; Asher Kolieboi <asher@civicdesign.org>; Christopher Patten <christopher@civicdesign.org>

Subject: UPDATE: Absentee instructions template & envelopes from Center for Civic Design: No action required

Hello everyone,

Thank you for taking time to review the CCD materials and ask questions today.

CTCL is putting the brakes on operation envelope with the WI-5 because:

- WEC wants everyone in the state using the same formats
- WEC wants to complete new envelope design work next year
- WEC shared uniform instructions today

Apologies for any confusion. Please reach out with any questions or concerns. And keep truckin'.

Stay safe out there,

Whitney M

On Tue, Aug 18, 2020 at 6:36 PM Witzel-Behl, Maribeth <MWitzel-Behl@cityofmadison.com> wrote:

Wow! Thank you!

I like the design. Is it possible to have the text larger in the instructions? I'm wondering how hard it might be for our older voters to read the 9-point font.

Thank you!

- Maribeth

From: Whitney May <whitney@techandcivicliflife.org>

Sent: Tuesday, August 18, 2020 12:07 PM

To: Michelle Nelson <mnelson@kenosha.org>; Coolidge, Tara <tara.coolidge@cityofracine.org>; Celestine Jeffreys <Celestine.Jeffreys@greenbaywi.gov>; Witzel-Behl, Maribeth <MWitzel-Behl@cityofmadison.com>; cwooda@milwaukee.gov; Kris.Teske@greenbaywi.gov

Cc: Josh Goldman <josh@techandcivicliflife.org>; Asher Kolieboi <asher@civicdesign.org>; Christopher Patten <christopher@civicdesign.org>

Subject: Absentee instructions template & envelopes from Center for Civic Design: Feedback requested by Friday

Caution: This email was sent from an external source. Avoid unknown links and attachments.

Hello Claire, Celestine, Kris, Tara, Michelle, and Maribeth:

You are the famous WI-5. Congrats on successful administration of last week's state primary! Excited to see November be an even bigger success for you and your teams.

With November in mind, I'm cc'ing the designers from Center for Civic Design, Asher & Christopher. CCD is one of the amazing technical assistance partners available to support the WI-5 (we really do need to get WI-5 tshirts).

Since we've heard interest from you about what other cities are doing, we thought it would be helpful to gather feedback on absentee envelopes and instructions from the WI-5 cohort as a group rather than gathering feedback separately.

- Here are the absentee instructions designed by CCD
 - It's a template in a Word doc
 - You can edit and customize for your city
 - Christopher and Asher are available to consult on design
 - Christopher and Asher have designed this by combining CCD's best practices and language from Madison's instructions.

- Here are the absentee envelopes designed by CCD
 - CCD has been working on the design with WEC
 - CCD + Oxide Design are available to consult on design and printing with your printer
 - Consult can look like adjusting the templates, adding your contact and other information, working with your envelope vendors (if needed) as you fit the layouts into your process (including any size or placement adjustments), or just providing any support, advice, or reviews of proofs.

Do you and your teams have capacity to review these materials and provide questions and feedback to CTCL & CCD before the end of the week?

We know you are all working on tight timelines for printing and collating absentee materials. Please let CTCL & CCD know how we can be most helpful moving forward. If it's useful, grant funds are available for cities that want to print new envelopes.

Thank you,
Whitney & Josh from CTCL

--

Whitney May

Director of Government Services

Center for Tech and Civic Life

whitney@techandcivicliflife.org

(919) 799-6173

she/her

--

Whitney May

Director of Government Services

Center for Tech and Civic Life

whitney@techandcivicliflife.org

(919) 799-6173

she/her

--

Whitney May

Director of Government Services

Center for Tech and Civic Life

whitney@techandcivicliflife.org

(919) 799-6173

she/her

Deanna Debruler

From: Celestine Jeffreys
Sent: Monday, August 17, 2020 5:36 PM
To: Whitney May
Subject: RE: Cities Project: Green Bay, WI advertising plan for November

Follow Up Flag: Follow up
Flag Status: Completed

Awesome, Whitney, thanks!!

Celestine Jeffreys
Chief of Staff, Mayor's Office
City of Green Bay

From: Whitney May [mailto:whitney@techandciviclelife.org]
Sent: Monday, August 17, 2020 5:33 PM
To: Celestine Jeffreys <Celestine.Jeffreys@greenbaywi.gov>
Cc: eric@modernelections.org
Subject: Cities Project: Green Bay, WI advertising plan for November

Hi Celestine,

During our last check in call you expressed the need for a communications consultant to review your advertising plan for November.

Eric Ming, cc'd, is the Communications Director for CSME, one of the technical assistance partners for the grant. He's from Wisconsin and he's a big Packers fan.

Hi Eric,

Celestine Jeffreys is Chief of Staff for the Mayor and she's the Green Bay lead for the implementation of their safe voting plan.

Here's what I've heard from Celestine so far:

- o They'd like to do radio ads on local Spanish-language radio stations, as well as geofencing.
- o They have a slogan, "Mailed it" and a mood board.
- o This is an urgent need.

I'm sure she has more to add to the conversation, so I'll let y'all take it from here.

Thanks again for your work on this,
Whitney M

--

Whitney May
Director of Government Services
Center for Tech and Civic Life

whitney@techandciviclife.org
(919) 799-6173
she/her

Deanna Debruler

From: Celestine Jeffreys
Sent: Thursday, September 17, 2020 5:53 AM
To: Whitney May
Cc: Liz Howard
Subject: RE: Green Bay, WI + Brennan Center: Election integrity efforts

Thank you, Whitney for connecting us!

Dear Liz,

A pleasure to meet you over email!

On Monday the 28th, Clerk Teske, the Police Chief and two commanders, Commander Warych and Commander Ebel, will meet to discuss election security. Commander Paul Ebel collects and responds to Department of Homeland Security bulletins. He also arranges security for visiting dignitaries. I'm going to connect the two of you, because you speak the same language and can easily discuss and prepare security needs for Election Day.

Thank you!

Celestine Jeffreys
Chief of Staff, Mayor's Office
City of Green Bay

From: Whitney May <whitney@techandcivillife.org>
Sent: Wednesday, September 16, 2020 6:42 PM
To: Celestine Jeffreys <Celestine.Jeffreys@greenbaywi.gov>
Cc: Liz Howard <howardl@brennan.law.nyu.edu>
Subject: Green Bay, WI + Brennan Center: Election integrity efforts

Hi Celestine,

I'm connecting you with Liz Howard at the Brennan Center. They focus on election integrity in lots of shapes and forms, including post-election audits and cybersecurity just to name a couple. Liz is amazing and I think she will be a good person to bounce ideas off of when it comes to the election security and integrity questions you have in Green Bay.

Hey Liz,

Celestine is the Green Bay Mayor's Chief of Staff. She is taking on a lot of the responsibilities with implementing the Green Bay Safe Voting Plan. Right now she is talking with her local leaders and advocates about balancing the transparency and safety of the election process. She's in conversation with her police lieutenant about some options that he and the department can provide.

I hope y'all can find time to connect soon and share ideas. And I'll let you take it from here!

Stay healthy and safe out there,
Whitney

Whitney May

Director of Government Services

Center for Tech and Civic Life

whitney@techandciviclife.org

(919) 799-6173

she/her

Deanna Debruler

From: Liz Howard <howardl@brennan.law.nyu.edu>
Sent: Wednesday, September 16, 2020 9:40 PM
To: Whitney May; Celestine Jeffreys
Subject: RE: Green Bay, WI + Brennan Center: Election integrity efforts

Thanks, Whitney!

Celeste, so nice to "meet" you! I would love to connect anytime. Unfortunately, I'm on a plane most of tomorrow, but I'm very flexible on Friday (except 2:45 – 4:15 ET). Just let me know if there's a good time for you on Friday or if you would like me to go ahead and send some options for next week.

Thank you both for everything you're doing!

Liz

From: Whitney May <whitney@techandcivicliflife.org>
Sent: Wednesday, September 16, 2020 7:42 PM
To: Celestine Jeffreys <Celestine.Jeffreys@greenbaywi.gov>
Cc: Liz Howard <howardl@brennan.law.nyu.edu>
Subject: Green Bay, WI + Brennan Center: Election integrity efforts

Hi Celestine,

I'm connecting you with Liz Howard at the Brennan Center. They focus on election integrity in lots of shapes and forms, including post-election audits and cybersecurity just to name a couple. Liz is amazing and I think she will be a good person to bounce ideas off of when it comes to the election security and integrity questions you have in Green Bay.

Hey Liz,

Celestine is the Green Bay Mayor's Chief of Staff. She is taking on a lot of the responsibilities with implementing the Green Bay Safe Voting Plan. Right now she is talking with her local leaders and advocates about balancing the transparency and safety of the election process. She's in conversation with her police lieutenant about some options that he and the department can provide.

I hope y'all can find time to connect soon and share ideas. And I'll let you take it from here!

Stay healthy and safe out there,
Whitney

--

Whitney May
Director of Government Services
Center for Tech and Civic Life
whitney@techandcivicliflife.org
(919) 799-6173
she/her

Deanna Debruler

From: Celestine Jeffreys
Sent: Thursday, October 15, 2020 6:53 PM
To: Kris Teske
Subject: RE: 2020-10-14 CGB Vote Countdown

I understand. I think it's all fixed now.

Celestine Jeffreys
Chief of Staff, Mayor's Office
City of Green Bay

From: Kris Teske <Kris.Teske@greenbaywi.gov>
Sent: Thursday, October 15, 2020 9:56 AM
To: Sam Hutchison <sam@hvsproductions.com>
Cc: Celestine Jeffreys <Celestine.Jeffreys@greenbaywi.gov>; Isabel Brinker <IBrinker@kw2madison.com>; Saralynn Finn <saralynn@voteathome.org>
Subject: RE: 2020-10-14 CGB Vote Countdown

I'm sorry, I am so busy. I should have crossed off masks required.

Kris Teske, WCMC
Green Bay City Clerk
100 N. Jefferson St., Rm 106
Green Bay, WI 54301
920-448-3014



From: Sam Hutchison [<mailto:sam@hvsproductions.com>]
Sent: Thursday, October 15, 2020 9:30 AM
To: Kris Teske <Kris.Teske@greenbaywi.gov>
Cc: Celestine Jeffreys <Celestine.Jeffreys@greenbaywi.gov>; Isabel Brinker <IBrinker@kw2madison.com>; Saralynn Finn <saralynn@voteathome.org>
Subject: RE: 2020-10-14 CGB Vote Countdown

Thank you Kris! Here's a revised copy with changes incorporated.

Sam Hutchison

sam@hvsproductions.com

HVS Advertising-Marketing | A Division of Image Keepers, Inc.
2021 S. Webster Ave. Green Bay, WI 54301-2257
920.430.5131 ext. 224

From: Kris Teske [<mailto:Kris.Teske@greenbaywi.gov>]
Sent: Thursday, October 15, 2020 9:19 AM
To: Sam Hutchison <sam@hvsproductions.com>
Cc: Celestine Jeffreys <Celestine.Jeffreys@greenbaywi.gov>; Isabel Brinker <IBrinker@kw2madison.com>; Saralynn Finn <saralynn@voteathome.org>
Subject: RE: 2020-10-14 CGB Vote Countdown

Here are my corrections and additions.

Kris Teske, WCMC
Green Bay City Clerk
100 N. Jefferson St., Rm 106
Green Bay, WI 54301
920-448-3014



From: Sam Hutchison [<mailto:sam@hvsproductions.com>]
Sent: Wednesday, October 14, 2020 3:19 PM
To: Kris Teske <Kris.Teske@greenbaywi.gov>
Cc: Celestine Jeffreys <Celestine.Jeffreys@greenbaywi.gov>; Isabel Brinker <IBrinker@kw2madison.com>; Saralynn Finn <saralynn@voteathome.org>
Subject: FW: 2020-10-14 CGB Vote Countdown

Hi Kris,

We've prepared some daily Election Countdown copy to be used for social media posts and talking points. Celestine has made some revisions and corrections, and asked me to send it to you as well for review. Let me know if you notice anything that is incorrect or you would like changed or worded differently.

Thank you,

Sam Hutchison

sam@hvsproductions.com
HVS Advertising-Marketing | A Division of Image Keepers, Inc.
2021 S. Webster Ave. Green Bay, WI 54301-2257
920.430.5131 ext. 224

From: Celestine Jeffreys [<mailto:Celestine.Jeffreys@greenbaywi.gov>]
Sent: Wednesday, October 14, 2020 2:55 PM
To: Sam Hutchison <sam@hvsproductions.com>
Subject: RE: 2020-10-14 CGB Vote Countdown

That would be good, thanks!

Celestine Jeffreys
Chief of Staff, Mayor's Office
City of Green Bay

From: Sam Hutchison <sam@hvsproductions.com>
Sent: Wednesday, October 14, 2020 2:53 PM
To: Celestine Jeffreys <Celestine.Jeffreys@greenbaywi.gov>
Subject: RE: 2020-10-14 CGB Vote Countdown

Thanks Celestine,

No, Kris wasn't copied in. I can incorporate all of your revisions and send an updated version to you and Kris for review.

Sam

Sam Hutchison

sam@hvsproductions.com

HVS Advertising-Marketing | *A Division of Image Keepers, Inc.*
2021 S. Webster Ave. Green Bay, WI 54301-2257
920.430.5131 ext. 224

From: Celestine Jeffreys [<mailto:Celestine.Jeffreys@greenbaywi.gov>]
Sent: Wednesday, October 14, 2020 2:48 PM
To: Isabel Brinker <IBrinker@kw2madison.com>; Sam Hutchison <sam@hvsproductions.com>
Subject: 2020-10-14 CGB Vote Countdown

Here are my changes. Did Kris submit hers as well?

CMJ

Deanna Debruler

From: Saralynn Finn <saralynn@voteathome.org>
Sent: Monday, October 26, 2020 3:02 PM
To: Shelby Edlebeck
Cc: Sam Hutchison; Celestine Jeffreys; Kevin Warych; Kim Wayte; Diana Ellenbecker; Michael Spitzer-Rubenstein
Subject: Re: 2020-10-25 Voter Navigator FAQ--cmj

Well done!

On Mon, Oct 26, 2020 at 12:26 PM Shelby Edlebeck <Shelby.Edlebeck@greenbaywi.gov> wrote:

The FAQs have been added to the bottom of the Elections webpage: <https://greenbaywi.gov/Elections>

Or they can be found directly here: <https://greenbaywi.gov/faq.aspx?TID=81>

Thank you,

Shelby Edlebeck

920.448.3207

From: Saralynn Finn [mailto:saralynn@voteathome.org]
Sent: Monday, October 26, 2020 1:53 PM
To: Sam Hutchison <sam@hvsproductions.com>
Cc: Celestine Jeffreys <Celestine.Jeffreys@greenbaywi.gov>; Kevin Warych <Kevin.Warych@greenbaywi.gov>; Kim Wayte <Kim.Wayte@greenbaywi.gov>; Diana Ellenbecker <Diana.Ellenbecker@greenbaywi.gov>; Michael Spitzer-Rubenstein <michael@voteathome.org>; Shelby Edlebeck <Shelby.Edlebeck@greenbaywi.gov>
Subject: Re: 2020-10-25 Voter Navigator FAQ--cmj

Absolutely!

On Mon, Oct 26, 2020 at 11:52 AM Sam Hutchison <sam@hvsproductions.com> wrote:

Great idea.

Sam Hutchison

sam@hvsproductions.com

HVS Advertising-Marketing | A Division of Image Keepers, Inc.

2021 S. Webster Ave. Green Bay, WI 54301-2257

920.430.5131 ext. 224

From: Celestine Jeffreys [mailto:Celestine.Jeffreys@greenbaywi.gov]

Sent: Monday, October 26, 2020 1:41 PM

To: Kevin Warych <Kevin.Warych@greenbaywi.gov>; Kim Wayte <Kim.Wayte@greenbaywi.gov>; Diana Ellenbecker <Diana.Ellenbecker@greenbaywi.gov>

Cc: Michael Spitzer-Rubenstein <michael@voteathome.org>; Saralynn Finn <saralynn@voteathome.org>; Sam Hutchison <sam@hvsproductions.com>; Shelby Edlebeck <Shelby.Edlebeck@greenbaywi.gov>

Subject: RE: 2020-10-25 Voter Navigator FAQ--cmj

That's a good thought!

Kim, Diana, Sam, Saralynn, Shelby and Michael, what do you think about posting this on our website?

Celestine Jeffreys

Chief of Staff, Mayor's Office

City of Green Bay

From: Kevin Warych <Kevin.Warych@greenbaywi.gov>

Sent: Monday, October 26, 2020 1:26 PM

To: Celestine Jeffreys <Celestine.Jeffreys@greenbaywi.gov>

Subject: RE: 2020-10-25 Voter Navigator FAQ--cmj

Can we get this on the city website...this is good info.

Then we can share it. but this needs to come from the city and not the PD

You are doing great....we are in this together!!

From: Celestine Jeffreys <Celestine.Jeffreys@greenbaywi.gov>
Sent: Monday, October 26, 2020 10:05 AM
To: Kala Lardinois <Kala.Lardinois@greenbaywi.gov>; Terri Racine <Terri.Racine@greenbaywi.gov>; Dawn Ouradnik <Dawn.Ouradnik@greenbaywi.gov>; Terry Sorelle <Terry.Sorelle@greenbaywi.gov>
Cc: Diana Ellenbecker <Diana.Ellenbecker@greenbaywi.gov>; Kevin Warych <Kevin.Warych@greenbaywi.gov>; Nina Robinette <Nina.Robinette@greenbaywi.gov>
Subject: 2020-10-25 Voter Navigator FAQ--cmj

Hello!

Thank you for pitching in. I know this is a frantic time, and I deeply appreciate your patience and calm.

Please find attached some information that may help you answer questions about the Election. The most important thing is to be humble. If you don't know the answer, take down their info and we can have someone call them back. At this point, the questions may be more complex, i.e., "I've been evicted and I'm temporarily living with my sister. Where do I vote?"

If you need something else, please let me know.

Appreciatively,

Celestine

Deanna Debruler

From: Celestine Jeffreys
Sent: Tuesday, August 18, 2020 3:02 PM
To: 'Whitney May'
Subject: RE: getting in touch

Thanks!! We had a very nice conversation and I'm ready to roll!



Celestine Jeffreys

Chief of Staff
Office of the Mayor
920.448.3006

From: Whitney May [mailto:whitney@techandcivicle.org]
Sent: Tuesday, August 18, 2020 2:45 PM
To: Eric Ming
Cc: Celestine Jeffreys
Subject: Re: getting in touch

Thanks, Eric! I don't need to be on this call, so I'll let Celestine drive scheduling.

On Tue, Aug 18, 2020 at 8:53 AM Eric Ming <eric@modernelections.org> wrote:

How does 3:30 CT/ 4:30 ET today or 1:00 PM CT/2:00 PM ET sound? We can use my conference line: [920-297-4742](tel:920-297-4742);no pin

On Mon, Aug 17, 2020 at 6:51 PM Celestine Jeffreys <Celestine.Jeffreys@greenbaywi.gov> wrote:

Eric,

It's a pleasure to meet you by email!

Whitney connected us and we're eager to get started on a media campaign that would include the items Whitney listed:

- o Radio ads on local Spanish-language radio stations, as well as geofencing.
- o They have a slogan, "Mailed it" and a mood board.
- o This is an urgent need.

Would you like to see the information I've already collected on geofencing and the cost of radio ads on the Spanish language radio? Attached is our mood board (we selected mood board 2). We've already sent out a document (attached) so I'd like to keep that look.

Here is my schedule for the rest of the week. Although I'm off on Friday, I would be available for a call Friday morning at 9:00 central.

Thanks!

The screenshot shows a calendar for August 17-21, 2020, with a daily task list. The days are: Tuesday (18), Wednesday (19), Thursday (20), and Friday (21). The tasks are as follows:

- Tuesday (18):**
 - Water Registration w/COA, some water meter
 - review script/send to mayor
 - MEET WITH DIANA ELLENBECKER - FISHAN
 - Buy single serve hot cream for 2nd floor
 - Review Council Agenda, Vanessa, Eric, Cel
 - Prep GBPA Agenda
 - Celestine's Office
 - Laura Schrey
 - Digital Access Discussion
 - See Zoom link below
 - Ann McCutcher
 - Zoom meeting with Mayor, Celestine, Chief S
 - Submit Scores to Jan
 - DIGITAL Video Filming
 - Get community groups together
 - Sofia and Celestine
 - MSB://VCS244E:zoom Meeting 438812972
 - Celestine Jeffrey
- Wednesday (19):**
 - Employer Appreciation Week
 - Cheryl and Celestine
 - Phone
 - Celestine Jeffrey
 - Leitch Park TV Charger
 - Mamela
 - Karrie Lohm
 - PR Team
 - Deadline for News
 - MSB://VCS244E:zoom Meeting 438812972
 - Celestine Jeffrey
 - Invitation: Ballot Drop Boxes-Green Bay @ WI
 - MSB://VCS244E:zoom Meeting 942992544697 Meeting
 - ryan@electiongroup.com
 - [S] development team
 - zoom meeting
 - Karen Vukob
 - Development Team Meeting
 - Mayor's Office
 - Terry Loredo
 - CTC: add one
 - Set up next week's slides
- Thursday (20):**
 - Mayor not available
 - PACKET DEADLINE
 - Staff check in noon
 - Celestine and Mayor
 - Mayor's Office
 - Celestine Jeffrey
 - Convo weekly phc
 - Whitney and Celestine
 - MSB://VCS244E:zoom Meeting 942992544697 Meeting
 - Celestine Jeffrey
 - FW: Green Bay Green
 - Style Meeting
 - Benninghoff, Banger
 - Monthly GIC Member phone
 - Celestine Jeffrey
 - OO BUDGET IN TYLER
- Friday (21):**
 - Celestine off, Celestine Jeffrey
 - APPROVE TIME/STEP CAR

Celestine Jeffreys
 Chief of Staff, Mayor's Office
 City of Green Bay

The contents of this email are confidential, intended for the recipient only, and may be legally protected from disclosure. Please do not forward or disclose any information contained in this message without permission from the sender.

--

Whitney May
Director of Government Services
Center for Tech and Civic Life
whitney@techandcivicliflife.org
(919) 799-6173
she/her

Deanna Debruler

From: Diana Ellenbecker
Sent: Thursday, October 1, 2020 3:57 PM
To: Kris Teske; Vanessa Chavez; Kim Wayte
Subject: RE: Dayna in Green Bay

[Redacted]

Thank you,
Diana

From: Kris Teske
Sent: Thursday, October 1, 2020 3:39 PM
To: Vanessa Chavez <Vanessa.Chavez@greenbaywi.gov>; Diana Ellenbecker <Diana.Ellenbecker@greenbaywi.gov>; Kim Wayte <Kim.Wayte@greenbaywi.gov>
Subject: RE: Dayna in Green Bay

[Redacted]

Kris Teske, WCMC
Green Bay City Clerk
100 N. Jefferson St., Rm 106
Green Bay, WI 54301
920-448-3014



From: Vanessa Chavez
Sent: Thursday, October 1, 2020 3:37 PM
To: Kris Teske <Kris.Teske@greenbaywi.gov>; Diana Ellenbecker <Diana.Ellenbecker@greenbaywi.gov>; Kim Wayte <Kim.Wayte@greenbaywi.gov>
Subject: RE: Dayna in Green Bay

[Redacted]

[Redacted]

Vanessa R. Chavez, *City Attorney*
City of Green Bay
(920) 448-3080
Vanessa.Chavez@greenbaywi.gov

LEGAL DISCLAIMER: This message and all attachments may be confidential or protected by privilege. If you are not the intended recipient, you are hereby notified that any disclosure, copying, distribution or use of the information contained in or attached to this message is strictly prohibited. Please notify the sender of the delivery error by replying to this message, and then delete it from your system. Thank you.

From: Kris Teske
Sent: Thursday, October 1, 2020 3:08 PM
To: Diana Ellenbecker <Diana.Ellenbecker@greenbaywi.gov>; Kim Wayte <Kim.Wayte@greenbaywi.gov>; Vanessa Chavez <Vanessa.Chavez@greenbaywi.gov>
Subject: FW: Dayna in Green Bay

Hi,

[REDACTED]

Thank you,

Kris Teske, WCMC
Green Bay City Clerk
100 N. Jefferson St., Rm 106
Green Bay, WI 54301
920-448-3014



From: Whitney May [<mailto:whitney@techandciviclelife.org>]
Sent: Wednesday, September 30, 2020 8:05 AM
To: Celestine Jeffreys <Celestine.Jeffreys@greenbaywi.gov>; Kris Teske <Kris.Teske@greenbaywi.gov>
Cc: Ryan Chew <ryan@electionsgroup.com>
Subject: Dayna in Green Bay

Hi Celestine and Kris,

Having spoken with each of you about the tremendous amount of work you're doing in the sprint towards November, I think both of your heroic efforts could benefit from another set of professional hands in Green Bay.

Dayna Causby, who you've spoken with from Elections Group, is available and ready to be in Green Bay as early as the week of October 5. She can help Celestine with Voter Navigators and Dropboxes – making sure folks are trained and boxes are secure. She can help Kris with Central Count – making sure it's set up in a way that's safe and efficient for the Clerk's staff and observers. Essentially, she can take on any election tasks that you assign. And, if she's there with you, I imagine this will cut down on some of the back-and-forth with phone calls and emails.

I think I mentioned this before, but we have another person from Elections Group who is assisting Claire in Milwaukee. He moved there in September. So, all of this to say, having Dayna in Green Bay isn't a new practice for the partners who are supporting the WI-5.

What do you think? Are y'all open to Dayna helping you in Green Bay?

We can also discuss it in our call tomorrow.

Thanks for your consideration,
Whitney

--

Whitney May
Director of Government Services
Center for Tech and Civic Life
whitney@techandciviclife.org
(919) 799-6173
she/her

Deanna Debruler

From: Celestine Jeffreys
Sent: Monday, July 13, 2020 11:06 PM
To: 'Tiana Epps-Johnson'
Subject: Uprising Strategies

Follow Up Flag: Follow up
Flag Status: Flagged

Tiana,

I'm not exactly sure how this works, but I received the email below from Mr. Sam Munger.

Is he working with you? As far as I'm concerned I am taking all of my cues from CTCL and work with those you recommend.

Let me know if I should open this door or not.

Celestine

Ms. Jeffreys - I'm reaching out on behalf of the National Vote at Home Institute (www.voteathome.org), a nonprofit, nonpartisan organization made up of former election administrators offering deep expertise and technical assistance on vote by mail best practices. NVAHI works closely with the Center for Tech and Civic Life and is a designated technical assistance provider on the election administration grant recently made to Green Bay and four other cities in Wisconsin. If it's of interest, NVAHI would be happy to present to the ad hoc committee on elections and give an overview of best practices for absentee voting and to discuss additional free technical support and expertise they can offer.

Amaad Rivera, with whom I've worked on a number of voting policy issues, suggested that you would be the best point of contact for the ad hoc committee; if there is someone else I should reach out to instead/in addition, please let me know.

I've attached some additional background on NVAHI. If you have any additional questions, please don't hesitate to drop me a line. Best,

Sam Munger

Sam Munger
Partner, Uprising Strategies
Washington, DC | Madison, WI
608.352.8178 (o) | 718.288.6477 (c)
sam@uprisingstrategies.com

Celestine Jeffreys
Chief of Staff, Mayor's Office
City of Green Bay

Badger Books

We encourage you to prioritize spending the grant funds on the programs, people, and technology related directly to the administration of your 2020 elections.

Point taken. What about purchasing express vote machines? The clerk hasn't mentioned that, I'm inquiring. We could use the express vote machines, if we can obtain them, right away.

Reallocating funds for voter outreach

Are you asking to move funds to the voter outreach bucket? If so, which bucket(s) are you pulling from?

- Increase Absentee Voting
- Launch Poll Worker Recruitment, Training, and Safety Efforts
- Ensure Safe and Efficient Election Day Administration

Could we take funds from the Badger book line? That's \$283K. If not, what about from the PPE/cough guards or the ballot folder lines?

There are probably 5 organizations in town that are focused on working with disadvantaged populations and/or with voters directly. I thought roughly \$5K (each) for their efforts (reimbursable expenses, of course). I don't have a sense of what's appropriate, so I haven't thought of a budget. Whitney, what do you recommend?

*Thanks!!
Celestine*

Ensure Safe and Efficient Election Day Administration		deadline and lead	
Safe and Efficient Election Day Administration--\$426,500			
purchase electronic poll books -- \$283,500 RFP	determine availability	10/15 Clerk (Kri:	
purchase high speed tabulator -- \$62,000 RFP			
purchase ballot opener and folder -- \$5,000 already purchased			
additional staff to process absentee ballots on election day - \$5,000 hire new staff, hire temps to replace staff? how does existing staff reassigned accomplish their own work?	determine need	9/8 Clerk (Kris)	
PPE -- \$15,000 already purchased			

~~cough guards~~ \$43,000

already purchased

~~disinfectant supplies~~ \$3,000

already purchased

30,000 black pens -- ???

obtain the pens

10/15 Procure (

From: Whitney May <whitney@techandcivillife.org>

Sent: Wednesday, August 26, 2020 7:16 PM

To: Celestine Jeffreys <Celestine.Jeffreys@greenbaywi.gov>

Cc: Kris Teske <Kris.Teske@greenbaywi.gov>

Subject: Re: FW: Following up on CTCL request

Hi Celestine & Kris,

Hope all is well in your neck of the woods. Regarding your questions, here's what I got:

Michael from National Vote at Home Institute

Feel free to connect with him. NVAHI is one of the Technical Assistance Partners -- they published the Election Official Communications Toolkit. I did let him know about your RFP that hit the street this week.

Badger Books

We encourage you to prioritize spending the grant funds on the programs, people, and technology related directly to the administration of your 2020 elections.

Reallocating funds for voter outreach

Are you asking to move funds to the voter outreach bucket? If so, which bucket(s) are you pulling from?

- Increase Absentee Voting
- Launch Poll Worker Recruitment, Training, and Safety Efforts
- Ensure Safe and Efficient Election Day Administration

Please continue to keep me updated and let us know how CTCL and partners can be most helpful for your team.

Stay safe,
Whitney

On Tue, Aug 25, 2020 at 10:55 AM Celestine Jeffreys <Celestine.Jeffreys@greenbaywi.gov> wrote:

Good morning, Whitney!

A few updates and a question.

First, did you connect the person below to us? I don't recall meeting him, but that's perhaps my oversight.

And some updates:

- To confirm: Is this your first time using Badger Books or are you ordering more Badger Books? This is the first time
- Ryan and Dayna from Elections Group should be able to think through poll book implementation with you. Would you like me to get this conversation going with them or would you like to reach out directly to them? I'll reach out to them about the badger books.
- Community groups:
 - I'm going to have our community relations aide reach out to community groups that will do voter outreach/education
 - Amazing! How do I go about reallocating funds and how much would you suggest? I think we have about a \$20K wiggle.

On Tue, Aug 25, 2020 at 10:55 AM Celestine Jeffreys <Celestine.Jeffreys@greenbaywi.gov> wrote:

Good morning, Whitney!

A few updates and a question.

First, did you connect the person below to us? I don't recall meeting him, but that's perhaps my oversight.

And some updates:

- Voter Outreach/Education:
 - The RFP for the public affairs firm is about to go on the street. It needs three weeks out there and then approval from committee and council. So that means we should have a firm engaged by mid-September, so probably 6 weeks of solid outreach/education. Does that square with what other municipalities are doing?
- Drop boxes:
 - We are going to talk about this internally on Thursday and make some decisions.
 - We'll most likely forego the drop boxes at the polling locations and go for 4 drop boxes, potentially at the fire stations.
 - We have another conversation with the drop box team today.
- Poll books:
 - Kris obtained a quote for poll books and printers (called Badger books). I believe there are some implementation issues, especially around training. Any thoughts?
- Community groups:
 - I'm going to have our community relations aide reach out to community groups that will do voter outreach/education

That's it, thanks!!

Reallocating funds for voter outreach

Are you asking to move funds to the voter outreach bucket? If so, which bucket(s) are you pulling from?

- Increase Absentee Voting
- Launch Poll Worker Recruitment, Training, and Safety Efforts
- Ensure Safe and Efficient Election Day Administration

Could we take funds from the Badger book line? That's \$283K. If not, what about from the PPE/cough guards or the ballot folder lines?

There are probably 5 organizations in town that are focused on working with disadvantaged populations and/or with voters directly. I thought roughly \$5K (each) for their efforts (reimbursable expenses, of course). I don't have a sense of what's appropriate, so I haven't thought of a budget. Whitney, what do you recommend?

Thanks!!

Celestine

Ensure Safe and Efficient Election Day Administration

	deadline and lead	
Safe and Efficient Election Day Administration--\$426,500		
purchase electronic poll books -- \$283,500 RFP	determine availability	10/15 Clerk (Kr
purchase high speed tabulator -- \$62,000 RFP		
purchase ballot opener and folder -- \$5,000 already purchased		
additional staff to process absentee ballots on election day - \$5,000 hire new staff, hire temps to replace staff? how does existing staff reassigned accomplish their own work?	determine need	9/8 Clerk (Kris)
PPE -- \$15,000 already purchased		

Deanna Debruler

From: Kris Teske
Sent: Friday, August 28, 2020 9:19 AM
To: Celestine Jeffreys
Cc: Diana Ellenbecker
Subject: FW: FW: Following up on CTCL request

We could use laptops with some of the money along with printers for registration and for the greeters.

Kris Teske, WCMC
Green Bay City Clerk
100 N. Jefferson St., Rm 106
Green Bay, WI 54301
920-448-3014



From: Celestine Jeffreys [mailto:Celestine.Jeffreys@greenbaywi.gov]
Sent: Thursday, August 27, 2020 8:23 PM
To: Whitney May <whitney@techandcivicliflife.org>
Cc: Kris Teske <Kris.Teske@greenbaywi.gov>
Subject: Re: FW: Following up on CTCL request

Michael from National Vote at Home Institute

Feel free to connect with him. NVAHI is one of the Technical Assistance Partners -- they published the Election Official Communications Toolkit. I did let him know about your RFP that hit the street this week.

Thanks, I'll reach out to him.

Badger Books

We encourage you to prioritize spending the grant funds on the programs, people, and technology related directly to the administration of your 2020 elections.

Point taken. What about purchasing express vote machines? The clerk hasn't mentioned that, I'm inquiring. We could use the express vote machines, if we can obtain them, right away.

Reallocating funds for voter outreach

Are you asking to move funds to the voter outreach bucket? If so, which bucket(s) are you pulling from?

- Increase Absentee Voting
- Launch Poll Worker Recruitment, Training, and Safety Efforts
- Ensure Safe and Efficient Election Day Administration

Deanna Debruler

From: Michael Spitzer-Rubenstein <michael@voteathome.org>
Sent: Wednesday, October 7, 2020 2:06 PM
To: Kris Teske
Subject: Re: Help with Absentee Ballot Curing Process?

Okay, I wouldn't want to disrupt anything given the date.

Do you have a few moments to speak, though? I've just been working with Celestine and so want to be sure I'm not overlooking any issues or places where we could help you.

Are you free this afternoon, Friday (any time before 3 PM) or Monday afternoon?

Michael

On Wed, Oct 7, 2020 at 2:59 PM Kris Teske <Kris.Teske@greenbaywi.gov> wrote:

We talked to a team already about curing ballots and found that it would take the same amount of time. So we decided our process was working the best for us and it's getting too late in the game to be starting new procedures.

Thank you,

Kris Teske, WCMC

Green Bay City Clerk

100 N. Jefferson St., Rm 106

Green Bay, WI 54301

920-448-3014



From: Michael Spitzer-Rubenstein [mailto:michael@voteathome.org]
Sent: Wednesday, October 7, 2020 9:49 AM
To: Kris Teske <Kris.Teske@greenbaywi.gov>
Subject: Help with Absentee Ballot Curing Process?

Hi Kris,

Can we help with curing absentee ballots that are missing a signature or witness signature/address?

We have a process map that we've worked out with Milwaukee for their process. We can also adapt the letter they're sending out with rejected absentee ballots along with a call script alerting voters (we can also get people to make the calls, too, so you don't need to worry about it). Celestine mentioned curing ballots might be something we could take off your plate.

When would be a good time to talk about it? I'm available this afternoon (after 2 PM), Friday (any time before 3) or next week. Any of those good for you?

Michael

--

Michael Spitzer-Rubenstein

State Lead for Wisconsin (Leadership Now Fellow)

National Vote at Home Institute

(310) 980-2872

he/him



Learn more about:

[Election Officials Center](#)

[Mail Ballot FAQs](#)

[Mail Ballot Security](#)

--

Michael Spitzer-Rubenstein

State Lead for Wisconsin (Leadership Now Fellow)
National Vote at Home Institute
(310) 980-2872
he/him



Learn more about:

[Election Officials Center](#)

[Mail Ballot FAQs](#)

[Mail Ballot Security](#)

Deanna Debruler

From: Michael Spitzer-Rubenstein <michael@voteathome.org>
Sent: Friday, October 30, 2020 1:27 PM
To: Amaad Rivera; Jaime Fuge; Diana Ellenbecker; Kim Wayte; Celestine Jeffreys
Subject: Revised Central Count Roles
Attachments: Central Count Poll Worker Needs v2.xlsx

As discussed this morning:

65 people for shift 1 (6 AM - 3 PM)
65 people for shift 2 (2 PM - 11 PM)
25 people for shift 3 (10 PM - close)

I think the one big remaining question is just delivering the machines over to KI on Monday but I know, Diana, that you're working on it.

Michael

--
Michael Spitzer-Rubenstein
State Lead for Wisconsin (Leadership Now Fellow)
National Vote at Home Institute

(██████████)
he/him

Learn more about:
[Election Officials Center](#)
[Mail Ballot FAQs](#)
[Mail Ballot Security](#)

Deanna Debruler

From: Celestine Jeffreys
Sent: Wednesday, September 30, 2020 12:43 PM
To: Ryan Chew; Dayna Causby; Michael Spitzer-Rubenstein; Kris Teske
Subject: RE: meeting?

Here's my schedule. I sent you an invitation to my calendar.



Celestine Jeffreys

Chief of Staff
Office of the Mayor
920.448.3006

From: Ryan Chew <ryan@electionsgroup.com>
Sent: Wednesday, September 30, 2020 12:22 PM
To: Dayna Causby <dayna@electionsgroup.com>; Celestine Jeffreys <Celestine.Jeffreys@greenbaywi.gov>; Michael Spitzer-Rubenstein <michael@voteathome.org>; Kris Teske <Kris.Teske@greenbaywi.gov>
Subject: meeting?

Folks,

The discussion of central count was cut short in the last meeting, and the intent was to schedule another call to continue the conversation.

In the next two days, I have meetings at 9:30 and 11:00 tomorrow, and I'm otherwise open. If next week is better, I currently have only an 11:00 meeting Monday, and otherwise Monday and Tuesday are pretty free.

Can you write back with your availability so we can get a call on the calendar?

I don't know city stats, but online I can see that Brown County as a whole has the second highest absentee request rate in the state, and is well above average in terms of the number returned. I hope the city is sharing in that trend, since it will make everything easier if they come back quickly.

Thanks

Ryan Chew
The Elections Group
m: 312 823-3384
ryan@electionsgroup.com

"A republic if you can keep it." - B. Franklin

"Winners always believe they won fairly. The aim of an election official is that losers recognize they lost fairly."

From: Kris Teske
Sent: Monday, October 12, 2020 1:50 PM
To: Amaad Rivera <Amaad.Rivera@greenbaywi.gov>
Subject: RE: Poll Workers

Hi Amaad,

We have a new program we are working with that was created by associates of the grant team CTCL. We sent out over 600 emails (some of these are the regular poll workers, who have declined) but wanted to give them a chance to change their mind. Unfortunately, something is wrong with the program and they can't figure it out. Jaime had to send another email out today to make sure we covered all of our bases. So we are still getting people replying. Right now we have 280 poll workers confirmed with applications still coming in.

Kris Teske, WCMC
Green Bay City Clerk
100 N. Jefferson St., Rm 106
Green Bay, WI 54301
920-448-3014



From: Amaad Rivera [<mailto:Amaad.Rivera@greenbaywi.gov>]
Sent: Monday, October 12, 2020 12:26 PM
To: Kris Teske <Kris.Teske@greenbaywi.gov>
Subject: Poll Workers

Kris,

I hope this email finds you well. There has been a ton of outreach to the city, as you know, on poll workers.

We had a Tele-Town Hall two weeks ago, where over 200 folks indicated that they would apply to be a poll worker.

Could you give me a status update on the number of poll workers we currently have and the current need?

- Amaad

Amaad Rivera-Wagner
Community Liaison
Office of the Mayor
100 North Jefferson Street - Room 200
Green Bay, Wisconsin 54301
Phone: 920.448.3210

Deanna Debruler

From: Saralynn Finn <saralynn@voteathome.org>
Sent: Thursday, October 15, 2020 12:52 PM
To: Kris Teske
Cc: Shelby Edlebeck; Mike Hronek; Celestine Jeffreys; Diana Ellenbecker
Subject: Re: Livestream Central Count

Just wanted to share an example of how Denver does livestream for inspiration.

Best,
Saralynn

On Sun, Oct 11, 2020 at 1:58 PM Saralynn Finn <saralynn@voteathome.org> wrote:
Hey Kris-

I don't think we've gotten a chance to 'meet' yet. My name is Saralynn Finn, I'm a Communications Strategist with NVAHI. We just published a white paper in conjunction with the Carter Center with tips for transparency in elections. I'm supporting jurisdictions to implement as many of them as possible.

I know there are concerns about space in your Central Count and also the ongoing COVID situation in Green Bay and the difficulty of social distancing with observers, this seemed like a potential solution to these two issues. Let me know if I can help in any way.

Best,
Saralynn

On Sat, Oct 10, 2020 at 4:03 PM Kris Teske <Kris.Teske@greenbaywi.gov> wrote:

Hi Shelby,

This is the first I heard of this so I don't have anything drawn up yet.

The plan is to have Central Count on 1st floor again (down the three halls). There will not be any DS 200 tabulators in the hall but I am planning on the DS 450 being in the Clerk's lobby. The observer area will be across the hall from the Clerk Office doors like before.

Let me know if you need anything else.

Kris Teske, WCMC
Green Bay City Clerk

100 N. Jefferson St., Rm 106

Green Bay, WI 54301

920-448-3014



From: Shelby Edlebeck [mailto:Shelby.Edlebeck@greenbaywi.gov]
Sent: Friday, October 9, 2020 12:22 PM
To: Kris Teske <Kris.Teske@greenbaywi.gov>
Cc: Mike Hronek <mike.hronek@greenbaywi.gov>; Saralynn Finn <saralynn@voteathome.org>; Celestine Jeffreys <Celestine.Jeffreys@greenbaywi.gov>
Subject: RE: Livestream Central Count

Hi Kris,

We are brainstorming how we would 'livestream' the central count taking place at City Hall on November 3rd. Do you have any ideas of what you are envisioning for this?

I was thinking of setting up laptops throughout the work zone with the cameras turned on (but mics muted) and streaming to a Zoom meeting. Then we could post the Zoom link on our website or email it out to whoever was interested in observing. Or whatever the protocol is for transparency during central count.

Let us know your thoughts or what you were thinking! ☺

Thank you,

Shelby Edlebeck

920.448.3207

From: Celestine Jeffreys
Sent: Thursday, October 8, 2020 5:15 PM
To: Shelby Edlebeck <Shelby.Edlebeck@greenbaywi.gov>
Cc: Mike Hronek <mike.hronek@greenbaywi.gov>; Saralynn Finn <saralynn@voteathome.org>
Subject: RE: Livestream Central Count

Shelby and Mike,

This sounds fine. Kris is the person to really determine where livestreaming needs to take place. I would imagine at each of the steps of the process not just tabulating the ballots.



Celestine Jeffreys

Chief of Staff

Office of the Mayor

920.448.3006

From: Shelby Edlebeck <Shelby.Edlebeck@greenbaywi.gov>
Sent: Thursday, October 08, 2020 3:04 PM
To: Mike Hronek <mike.hronek@greenbaywi.gov>; Celestine Jeffreys <Celestine.Jeffreys@greenbaywi.gov>
Subject: Livestream Central Count

I just got off the phone with Saralynn Finn and I'm brainstorming how we can livestream Central Count on election day so that observers do not enter our building.

My first thought is that we could "livestream" by basically just having a Zoom meeting all day.

Set up laptops with their cameras facing the big DS200 machines and having all laptops on mute and joined into the same Zoom meeting. Then we can post that Zoom meeting link on our website for observers. I can probably figure out a way to make sure people cannot unmute themselves and have conversations in the Zoom meeting throughout the day? It would just be a silent "livestream".

First things first, **Mike** – do you think we could muster up a few laptops to use that day?

Secondly, **Celestine** – do you like this idea? Where would you want the cameras on the laptops facing? At the DS200 machines or elsewhere?

Shelby Edlebeck

Multimedia Communication Specialist

City of Green Bay

920.448.3207

Deanna Debruler

From: Celestine Jeffreys
Sent: Wednesday, July 29, 2020 8:10 AM
To: 'Whitney May'
Subject: RE: 2020-07-28 Voter Navigator Job Draft

Follow Up Flag: Follow up
Flag Status: Completed

Whitney,

That's a good question, thank you!! I imagine there are lots of people who have graduated from college and are looking for a job. So that's why I raised the stakes. Also, a post-secondary degree would be beneficial because of the quick learning curve, the ability to be independent and organize time, and the need to manage paperwork.

Celestine Jeffreys
Chief of Staff, Mayor's Office
City of Green Bay

From: Whitney May [mailto:whitney@techandcivicliflife.org]
Sent: Tuesday, July 28, 2020 6:46 PM
To: Celestine Jeffreys <Celestine.Jeffreys@greenbaywi.gov>
Subject: Re: 2020-07-28 Voter Navigator Job Draft

I love that y'all are hiring for this position. Helping people navigate the voter journey is so important, especially this year. So thank you for prioritizing this, and you've described it in a really clear way.

Only question for you is about the education requirements. Would a high school diploma qualify someone or do you feel like some college coursework is required to be successful at the job? No wrong answer, just curious.

On Tue, Jul 28, 2020 at 5:22 PM Celestine Jeffreys <Celestine.Jeffreys@greenbaywi.gov> wrote:

What do you think?

--
Whitney May
Director of Government Services
Center for Tech and Civic Life
whitney@techandcivicliflife.org
(919) 799-6173
she/her

Central Count Absentee Ballot Processing Procedures

Table of Contents

Important Information.....	1	ExpressVote Ballots.....	6
Contents of Goldenrod Envelope.....	2	Emailed Ballots.....	6
Types of Ballots.....	2	Rejected Envelopes.....	7
Pre-Processing Procedures.....	3	Reconstructing A Ballot.....	8
Processing Official Ballots.....	5	Completed Work.....	11

Important Information

- ▶ You will be working in pairs safely distanced from each other
- ▶ We are taking as many safety precautions as possible, everyone will be issued mask(s) and gloves



- ▶ Absentee ballot processing will begin at **7:00 AM** when the manager announces:

“The polls are now open”
- ▶ All absentee ballot envelopes prior to being processed on Election Day have already been scanned, sorted into ward order, and alphabetized by last name
- ▶ Each team will receive **one** Ward Packet at a time

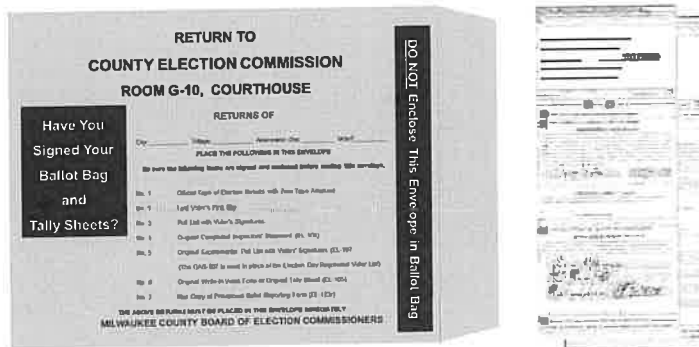

Contents of Goldenrod Envelope

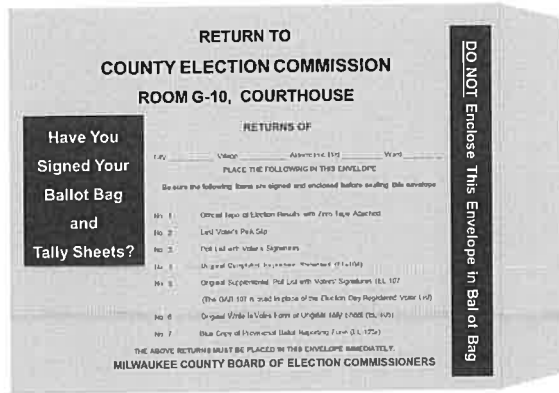

Used By Absentee Ballot Opening Team:

Used By Ballot Tabulating Team:

Ward Sign

Ward 1

Absentee Ballot Log

NAME	WARD	PRECINCT	PHONE	DOB	SEX	HT	WT	HAIR	EYES	MARKS	REMARKS
...

Ballot Bag

(GAB-104)

Voter Number Sheet

Registered Write-ins

Types of Ballot You Will Be Processing

▶ Official Ballots

- 90% of your ballots
- So long as the ballot is the correct ward and not damaged, nothing needs to be done other than assigning a voter number



▶ ExpressVote Ballots

- Assign voter number on bottom of ballot and keep a separate stack for each ward
- These **do not need to be reconstructed** unless there is damage

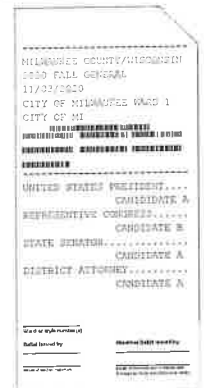

▶ Emailed

- All emailed ballots need to be reconstructed
- Keep the certificate and empty envelope with your absentee envelopes



▶ Federal Only Ballots

- All Federal only ballots need to be reconstructed
- Only reconstruct the offices that are on the original ballot
- ALL other races are left blank

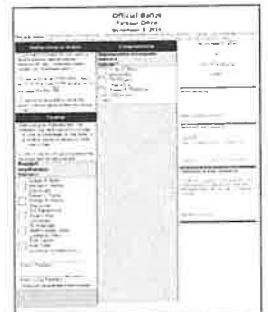

Pre-Processing Procedures

- 1** Remove all record keeping paperwork for the Goldenrod Envelope

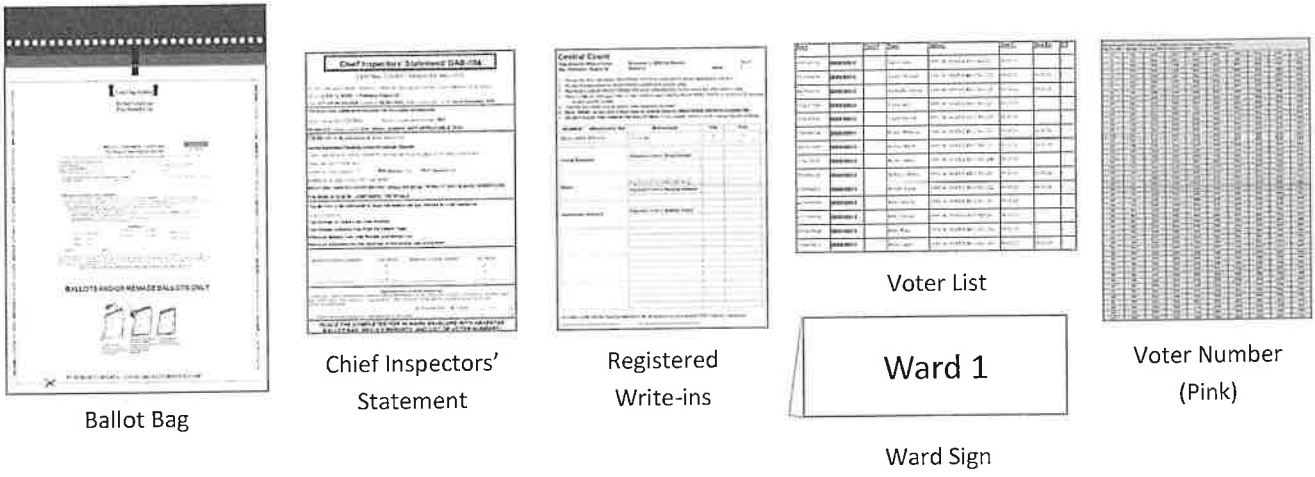

- 2** Confirm on the Chief Inspectors' Statement (GAB-104) that the serial number on the Ballot Bag matches the serial number on the GAB-104

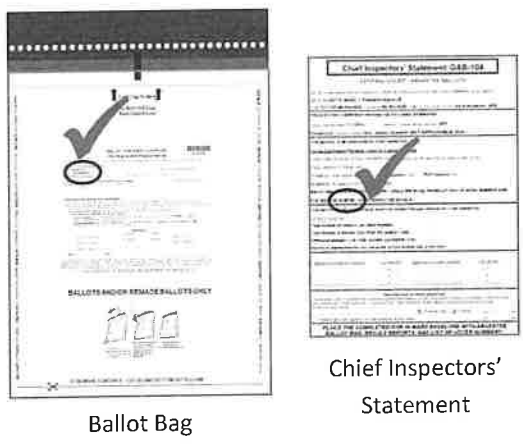

- 3** Circle and initial that the serial numbers match on the GAB-104

NUMBER OF BALLOTS FOR THIS WARD:
 BALLOT BAG CHAIN-OF-CUSTODY RECORD - CIRCLE AND INITIAL THE BALLOT BAG TIE SERIAL NUMBERS USED
 FOR WARD #1 IS 58190 CHIEF INSPECTOR INITIALS: CWV

- 4** You and your partner will sign that you are working on this ward

<u>Signatures of Election Inspectors</u>	<u>Time Worked</u>	<u>Signatures of Election Inspectors</u>	<u>Time Worked</u>
<u>Christa Wade-Vapp</u>	to _____	_____	to _____
<u>Jonathan Zupis</u>	to _____	_____	to _____
_____	to _____	_____	to _____
			00192

Pre-Processing Procedures

- 5 Place the ward sign on the edge of the table, so that it is visible to observers



Ward Sign

- 6 Split your ward's envelopes in half with your partner
**Keep them in alphabetical order*



- 7 Review the envelopes for:
 - ▶ Voter signature
 - ▶ Witness signature
 - ▶ Witness address
 (house number, street name, city)
**if written in red: accept*

2 Sign and date your envelope as the voter (below).

CERTIFICATION OF VOTER (Required!)

I certify, subject to the penalties for false statements of Wis. Stat. § 12.60(1)(b), that I am a resident of the ward of the municipality in the county of the state of Wisconsin indicated hereon, and am entitled to vote in the ward at the election indicated hereon; that I am not voting at any other location in this election; that I am unable or unwilling to appear at the polling place in the ward on election day, or I have changed my residence within the state from one ward to another later than 28 days before the election. I certify that I exhibited the enclosed ballot, unmarked, to the witness, that I then in the presence of the witness and in the presence of no other person marked the ballot and enclosed and sealed the ballot in this envelope in a manner that no one but myself and any person providing assistance under Wis. Stat. § 6.87(5), if I requested assistance, could know how I voted. I further certify that I requested this ballot.

X Jane Voter 10 25 20
 ▲ Signature of Voter ▲ Today's Date

(All voters must sign. If a voter is unable to sign, an assistant may sign the voter's name for them. The assistant must also sign their own name under the Certification of Assistant.)

CERTIFICATION OF ASSISTANT (if applicable)

I certify that the voter named on this certificate is unable to sign his/her name or make his/her mark due to a physical disability, and that I signed the voter's name at the direction and request of the voter.

X _____
 ▲ Signature of Assistant ▲

Note: Assistants must sign the voter's name for them in Step 2, in addition to the assistant signature on the line above. A witness signature in Step 3 is also required. The assistant may also be the witness.

3 Have your witness sign and write their address (below).

CERTIFICATION OF WITNESS (Required!)

I, the undersigned witness, subject to the penalties for false statements of Wis. Stat. § 12.60(1)(b), certify that I am an adult U.S. Citizen and that the above statements are true and the voting procedure was executed as stated. I am not a candidate for any office on the enclosed ballot (except in the case of an incumbent municipal clerk). I did not solicit or advise the voter to vote for or against any candidate or measure. I further certify that the name and address of the voter is correct as shown.

1. John Witness
 ▲ Signature of ONE Witness - An adult, U.S. citizen ▲

1203 Main St
 ▲ Address of Witness - Street address or box number (REQUIRED) ▲

Madison WI 53702
 ▲ Address of Witness - City, state, and zip code (REQUIRED) ▲

2. _____
 ▲ (If witnesses are Special Voting Deputies, both must sign) ▲

! IF ANY ENVELOPES ARE MARKED AS "REJECTED" SEE PAGE 7

Voter Signature

Witness Signature

Witness Address

- 8 After reviewing all the of the envelopes and removing any to be rejected, team members should take the envelopes to an envelope opening station in the room

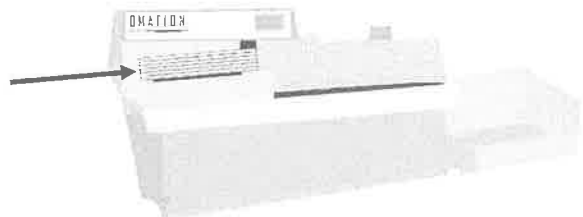

Return to your table, when the envelopes have been opened

Processing Official Ballots

- 1 Partner 1
 - A. Announce the voter's name
 - B. Number the envelope
 - C. Remove the ballot from the envelope
 - D. Number the ballot

Jane Voter

A



B

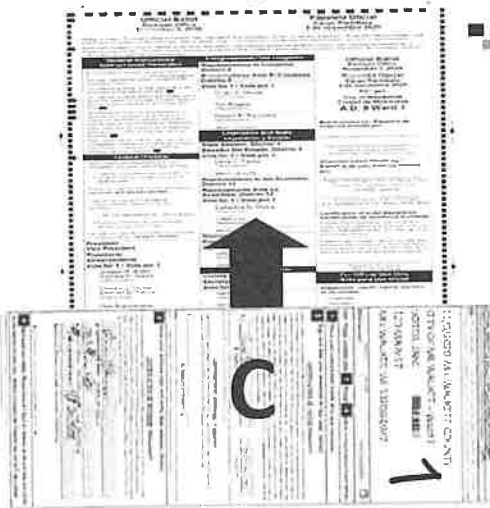

C

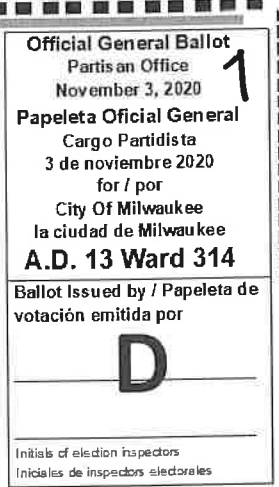

D

- 2 Partner 2
 - A. Announce the voter number
 - B. Cross the number off the voter number sheet
 - C. Record the number on the Absentee Voter Log

1

A

November 3, 2020 Fall General –Milwaukee Central Count Voter Numbers
 Site Name: Firehouse—Engine 38 District: 9 Ward 168

	51	101	151	201	251	301	351	401	451
1	52	102	152	202	252	302	352	402	452
2	53	103	153	203	253	303	353	403	453
3	54	104	154	204	254	304	354	404	454
4	55	105	155	205	255	305	355	405	455

Reg #		Voter #	Name	Address	Date Iss	Date Ret	WD
0705185990			Voter, Jane Q	10991 W DONNA RD UNIT 221	09/18/20		1
0067589459		1	Voter, Michael R	10991 W DONNA RD UNIT 222	09/18/20		1

- 3 Repeat until all envelopes are counted
 Keep envelopes in voter number order

Create a separate pile for ExpressVote ballots or ballots that need reconstruction

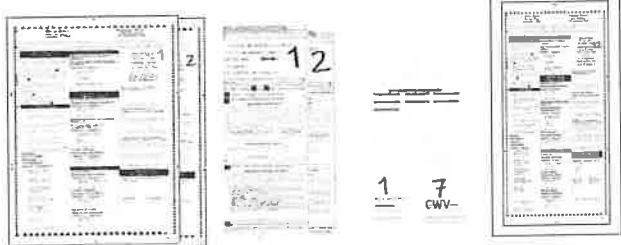

Processing ExpressVote Ballots

- 1** Partner 1
 - A. Announce the voter's name
 - B. Number the envelope
 - C. Remove the ballot from the envelope
 - D. Number the ballot

The form contains the following fields and handwritten entries:

- Ward or style number(s): 1
- Ballot Issued by: _____
- Initials of election inspectors: _____
- Absentee ballot issued by: CWV
- Initials of municipal clerk or deputy clerk (if issued by SVDs, both SVDs must initial.): _____

Handwritten numbers: '7' is written above 'CWV' and 'D' is written to the right of '7'.

- 2** Partner 2
 - A. Announce the voter number
 - B. Cross the number off the voter number sheet
 - C. Record the number on the Absentee Voter Log

! KEEP EXPRESSVOTE BALLOTS IN A SEPARATE PILE FROM THE OFFICIAL BALLOTS

Processing Emailed Ballots

- 1** Partner 1
 - A. Check for
 - ▶ Voter signature
 - ▶ Witness signature
 - ▶ Witness address
 - B. Open the envelope attached to the certificate
 - C. Remove the ballot from the envelope
 - D. Announce the voter's name
 - E. Number the envelope
 - F. Number the ballot
 - G. Certificate and envelope are added to Official Ballot envelopes stack
 - H. Place the ballot in a separate pile to be reconstructed

The form includes the following sections and handwritten entries:

- OFFICIAL ABSENTEE BALLOT APPLICATION AND CERTIFICATE**
- Section: **CERTIFICATE OF VOTER** with handwritten signature and date 10-1-20.
- Section: **CERTIFICATE OF WITNESS** with handwritten signature and date 7-9-1968.
- Section: **CERTIFICATE OF ASSISTANT** with a large handwritten letter **A**.

! EMAILED BALLOTS HAVE TO BE RECONSTRUCTED, SEE PAGE 8

- 2** Partner 2
 - A. Announce the voter number
 - B. Cross the number off the voter number sheet
 - C. Record the number on the Absentee Voter Log

Rejected Ballots

Envelopes are rejected for missing:

- Voter signature
- Witness signature
- Witness address

- ▶ Should already be marked for rejection in red marker ink or red rejection stamp at the beginning the batch of envelopes
 - ▶ Double check to make sure any have not been missed
 - ⇒ If the Election Commission has not already marked an envelope to be rejected, please confirm with a Central Count Manager
- ▶ These ballots are not assigned a voter number



1 Record them as "RAB" (Rejected Absentee Ballots) on the GAB-104 with a reason code

City of Milwaukee Election Commission GAB-104

Incident Number	DESCRIPTION OF INCIDENT	Time Incident Occurred	Chief Inspector Initials
Tally of Ballots Requiring Override			
Blank:			
Overvote:			
ROB - Reconstructed Official Ballot Codes D - Damaged P - Pencil/Pen Marks OS - Overseas (Federal only ballot) E - Emailed Reg Ballot OTH - Other w/explanation (provide)			
RAB - Rejected Absentee Ballot Certificate Envelope Codes NWS - No Witness Signature NVS - No Voter Signature T - Tampered/Taped NWA - No Witness Address OTH - Other w/explanation (provide)			
RAB 1	Jane Voter NWA		CWV/ML

- 2 Write on the outside of the envelope "RAB1"
 - * RAB (Rejected Absentee Ballot)
 - * Number each sequentially RAB-1, RAB-2, etc.

3 Rejected Envelopes

- ▶ Place the "Rejected" unopened envelope containing the ballot in the Goldenrod Envelope

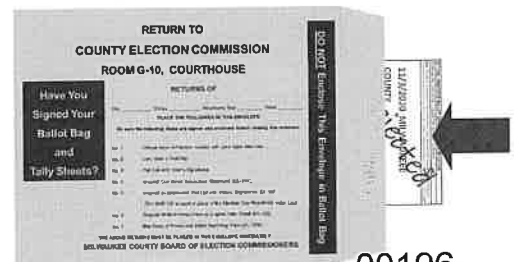
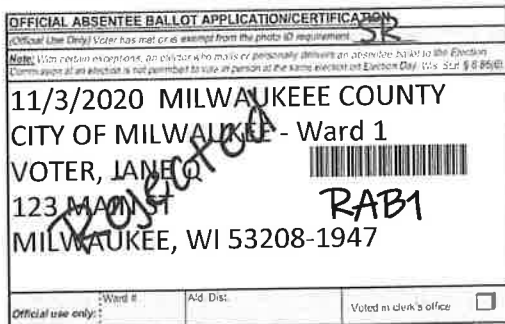

00196

Reconstructing a Ballot

If you open a ballot and it is visibly damaged (torn, crinkled, stained, etc.) or sent via email (not an official ballot) will have to reconstruct the ballot with your partner.

- ▶ **Both partners must always be present when reconstructing a ballot**
- ▶ **After you have assigned all your voter numbers for the ward, you should then reconstruct ballots**
- ▶ **Count the number of ballots that you need to reconstruct for the ward and get blank ballots from the Central Count Ballot Station**

1 Partner 1

- A. Announce the voter's name
- B. Number the envelope
- C. Remove the ballot from the envelope
- D. Number the ballot
- E. Place the ballot into a separate pile for reconstruction
- F. Keep the envelope (or certificate statement) with the other envelopes already processed

2 Partner 2

- A. Announce the voter number
- B. Cross the number off the voter number sheet
- C. Record the number on the Absentee Voter Log

3 Proceed to the Central Count Ballot Station to request the number of ballots that you will need to reconstruct

**The person that issues the ballots will have initialed/stamped with it "CWV" for the issuing authority*

Absentee ballot issued by /
Papeleta de voto ausente emitida
por

CWV

Initials of Municipal Clerk or Deputy Clerk
Iniciales de secretario municipal o
secretario suplente

If issues by SVDs, both must initial
Si es emitida por SVDs, ambos deben firmar

4 For each ballot, determine why you are reconstructing the ballot:

Reason	Code
Emailed Ballot	E
Damaged	D
Overseas (Federal Only Ballot)	OS
Pencil/Pen Marks (Not Fully Scanned)	P
Wrong Ward*	WW

** If the ballot was for the wrong ward, you will need to reconstruct the ballot with votes only for the races that are in both wards*

Reconstructing a Ballot

- 5 Record them as "ROB" (Reconstructed Official Ballot) on the GAB-104 with:
- The voter's number
 - Reason Code
 - Initials

City of Milwaukee Election Commission GAB-104

Incident Number	DESCRIPTION OF INCIDENT	Time Incident Occurred	Chief Inspector Initials
Tally of Ballots Requiring Override			
Blank:			
Overvote:			
ROB - Reconstructed Official Ballot Codes D - Damaged P - Pencil/Pen Marks OS - Overseas (Federal only ballot) E - Emailed Reg Ballot OTH - Other w/explanation (provide)			
RAB - Rejected Absentee Ballot Certificate Envelope Codes NWS - No Witness Signature NVS - No Voter Signature T - Tampered/Taped NWA - No Witness Address OTH - Other w/explanation (provide)			
ROB 1	#34 D		CWV/ML

- 5 On the **original** ballot:
- A. Select the reason for reconstruction
 - B. Write the ROB#
 - C. Write your initials and your partner's initials

- On the **reconstructed** ballot:
- A. Write the ROB#
 - B. Write your initials and your partner's initials

For Official Use Only

Inspectors: Identify ballots required to be remade:

A Overvoted
 Damaged
 Other

If this is the Original Ballot , write the serial number here: B <u>ROB1</u>	If this is the Duplicate Ballot , write the serial number here: _____
C <u>CWV</u> <u>ML</u>	_____

Initials of inspectors who remade ballot

For Official Use Only

Inspectors: Identify ballots required to be remade:

Overvoted
 Damaged
 Other

If this is the Original Ballot , write the serial number here: _____	If this is the Duplicate Ballot , write the serial number here: A <u>ROB1</u>
<u>ML</u>	B <u>CWV</u>

Initials of inspectors who remade ballot

Reconstructing a Ballot

- 7 On the **reconstructed** ballot:
Write the voter's number

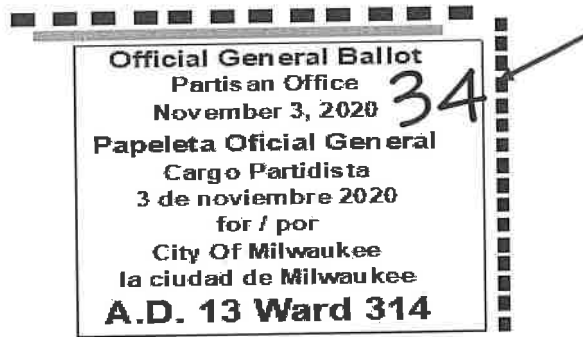

- 8 Hand your partner the **original** ballot
Partner 1:

▶ Read off the votes as the voter recorded

County / Condado	
County Clerk Secretario del Condado	
Vote for 1 / Vote por 1	
<input checked="" type="radio"/>	George Washington (Democratic)
<input type="radio"/>	write-in / por escrito:

Partner 2:

▶ Fill in votes on the ballot as the votes

County / Condado	
County Clerk Secretario del Condado	
Vote for 1 / Vote por 1	
<input checked="" type="radio"/>	George Washington (Democratic)
<input type="radio"/>	write-in / por escrito:

- 9 Hand **both** ballots to Partner 1
Partner 1:

Verify the reconstructed ballot matches

Original

County / Condado	
County Clerk Secretario del Condado	
Vote for 1 / Vote por 1	
<input checked="" type="radio"/>	George Washington (Democratic)
<input type="radio"/>	write-in / por escrito:

Reconstructed

County / Condado	
County Clerk Secretario del Condado	
Vote for 1 / Vote por 1	
<input checked="" type="radio"/>	George Washington (Democratic)
<input type="radio"/>	write-in / por escrito:

- 10 Refold and place the **original** ballot in the Goldenrod Envelope

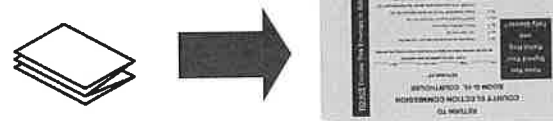

- 11 The **reconstructed** ballot is added to the stack of Official Ballots

Completed Work

- 1 Bundle all empty Absentee Envelopes in the order they were processed (voter number) with a rubber band and place them in the bin provided

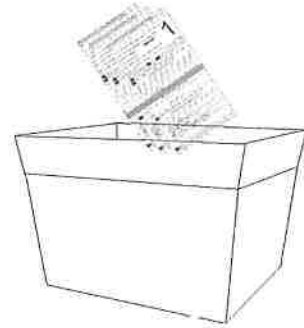

- 2 Initial the last voter number on the Voter Number Sheet

74	74	124	174
75	75 ML	125	175
28	76	126	176

- 3 Attempt to flatten the ballots
 - Bend them at the scored folds
 - Roll them in different directions

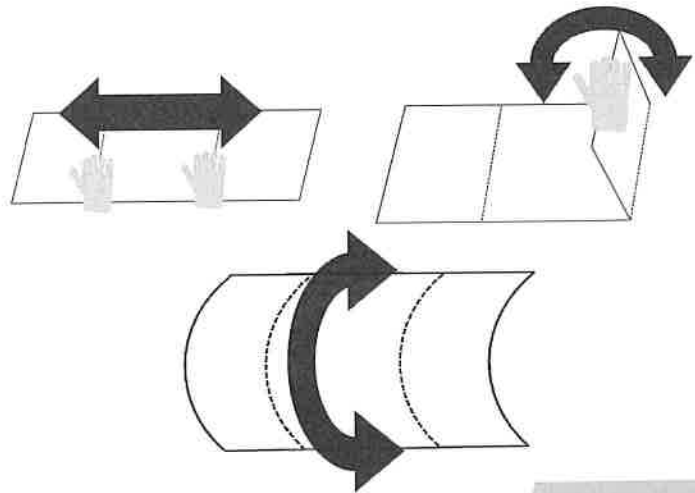

- 4 Prepare your processed ballots and paperwork to have them counted
 - A. Put the Ballot Bag, Voter Log, Ward Sign, Voter Number Sheet, Write-in Form, and GAB-104 back into the Goldenrod Envelope
 - B. Place the filled Goldenrod Envelope underneath the ballots

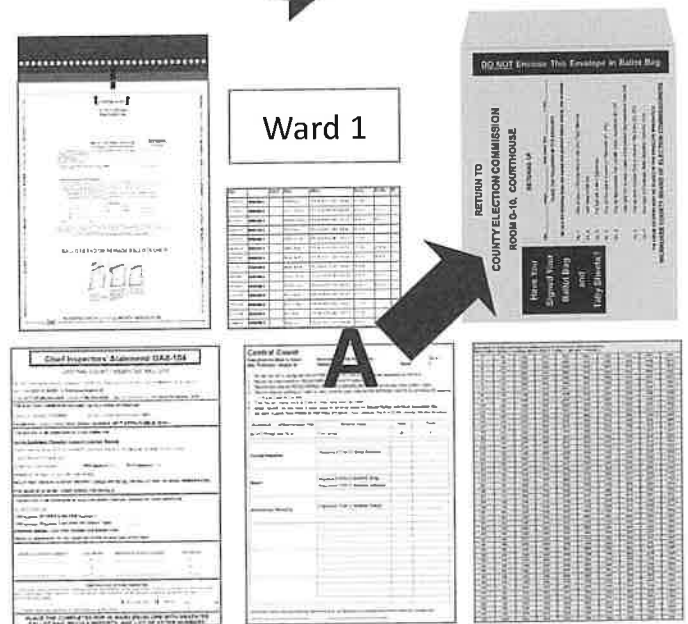
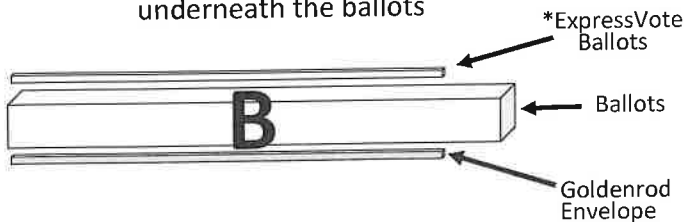

- 5 Take your ready to be counted work to the assigned counting station

Role	Name	Phone	Email	Notes
Ballot Prep Table 1 - A				
Ballot Prep Table 1 - B				
Ballot Prep Table 2 - A				
Ballot Prep Table 2 - B				
Ballot Prep Table 3 - A				
Ballot Prep Table 3 - B				
Ballot Prep Table 4 - A				
Ballot Prep Table 4 - B				
Ballot Prep Table 5 - A				
Ballot Prep Table 5 - B				
Ballot Prep Table 6 - A				
Ballot Prep Table 6 - B				
Ballot Prep Table 7 - A				
Ballot Prep Table 7 - B				
Ballot Prep Table 8 - A				
Ballot Prep Table 8 - B				
Ballot Prep Table 9 - A				
Ballot Prep Table 9 - B				
Ballot Prep Table 10 - A				
Ballot Prep Table 10 - B				
Ballot Prep Table 11 - A				
Ballot Prep Table 11 - B				
Ballot Prep Table 12 - A				
Ballot Prep Table 12 - B				
Ballot Prep Table 13 - A				
Ballot Prep Table 13 - B				
Ballot Prep Table 14 - A				
Ballot Prep Table 14 - B				
Ballot Prep Table 15 - A				
Ballot Prep Table 15 - B				
Ballot Prep Table 16 - A				
Ballot Prep Table 16 - B				
Ballot Prep Table 17 - A				
Ballot Prep Table 17 - B				
Ballot Prep Table 18 - A				
Ballot Prep Table 18 - B				
Ballot Prep Table 19 - A				
Ballot Prep Table 19 - B				
Ballot Prep Table 20 - A				
Ballot Prep Table 20 - B				
Ballot Prep Table 21 - A				
Ballot Prep Table 21 - B				

Ballot Prep Table 22 - A
Ballot Prep Table 22 - B
Ballot Prep Table 23 - A
Ballot Prep Table 23 - B
Ballot Prep Table 24 - A
Ballot Prep Table 24 - B
Envelope Opener 1
Envelope Opener 2
Envelope Opener 3
Envelope Opener 4
DS200 Tabulator 1
DS200 Tabulator 2
DS450 Tabulator - A
DS450 Tabulator - B
Reconstructor Table 1 - A
Reconstructor Table 1 - B
Reconstructor Table 2 - A
Reconstructor Table 2 - B
Ballot Runner & Flattener - A
Ballot Runner & Flattener - B
Ballot Sorter
Dropbox Ballot Receiver

With November in mind, I'm cc'ing the designers from Center for Civic Design, Asher & Christopher. CCD is one of the amazing technical assistance partners available to support the WI-5 (we really do need to get WI-5 tshirts).

Since we've heard interest from you about what other cities are doing, we thought it would be helpful to gather feedback on absentee envelopes and instructions from the WI-5 cohort as a group rather than gathering feedback separately.

- Here are the absentee instructions designed by CCD
 - It's a template in a Word doc
 - You can edit and customize for your city
 - Christopher and Asher are available to consult on design
 - Christopher and Asher have designed this by combining CCD's best practices and language from Madison's instructions.

- Here are the absentee envelopes designed by CCD
 - CCD has been working on the design with WEC
 - CCD + Oxide Design are available to consult on design and printing with your printer
 - Consult can look like adjusting the templates, adding your contact and other information, working with your envelope vendors (if needed) as you fit the layouts into your process (including any size or placement adjustments), or just providing any support, advice, or reviews of proofs.

Do you and your teams have capacity to review these materials and provide questions and feedback to CTCL & CCD before the end of the week?

We know you are all working on tight timelines for printing and collating absentee materials. Please let CTCL & CCD know how we can be most helpful moving forward. If it's useful, grant funds are available for cities that want to print new envelopes.

Thank you,
Whitney & Josh from CTCL

--



THE
ELECTIONS
GROUP

Guide to Ballot Drop Boxes

Issued by The Elections Group

Table of Contents

Overview	2
Planning	3
How Many Ballot Drop Boxes Do I Need?	3
Where Do I Place Them?	4
Purchasing Considerations	6
What Other Resources Will I Need?	13
How Do We Secure Ballot Boxes?	14
Ballot Retrieval	15
Driving Routes, Frequency, and Staffing Needs	15
Voter Outreach and Communication	18
Execution	19
Opening and Setup	19
Daily Collection of Ballot Drop Boxes	22
Election Night Closing	27
Common Mistakes and How to Prevent Them	30
Appendix A: Drop Box Vendors	31
Appendix B: Site Feasibility Planner	34



The Elections Group, 2020
This work is licensed under the Creative Commons Attribution-NonCommercial 4.0 International License. To view a copy of the license, visit creativecommons.org/licenses/by-nc/4.0.

Overview

Ballot drop boxes offer a secure, convenient alternative for voters to cast their completed mail ballots. They save money for voters in jurisdictions where return postage is not prepaid, and they can reduce costs for election authorities where postage is paid.

Voters like ballot drop boxes. In jurisdictions where vote-by-mail is prevalent, as many as 80 percent of voters choose to return their ballot at a ballot drop box.

A ballot drop box program can help build public trust in the election process. Ballot drop boxes can reassure voters who mistrust the postal system because of lost or delayed mail, or who worry about someone potentially tampering with their ballot. Ballot drop boxes also provide a solution for voters who are concerned about their signature being exposed to anyone outside of their local election office.

For election officials, ballot drop boxes ensure ballots are received in time to be processed. This is critical since many voters wait until Election Day to return their ballots.

This guide is divided into three sections.

- **Planning** will help election officials decide the type, location, equipment and staffing for three types of ballot drop boxes.
- **Voter Outreach and Communication** contains suggestions for promoting ballot drop box convenience and availability, and to publicize your request and return deadlines.
- **Execution** includes sample forms that can be used separate from this guide to train temporary staff and used as a daily checklists and chain of custody logs, including a section for Election Night.

As you review this guide, keep in mind accommodations for COVID-19 and social distancing requirements. For example, asking two unrelated workers to share a car ride may be a challenge. COVID-related considerations are addressed in the Planning section.

Planning

How Many Ballot Drop Boxes Do I Need?

Estimating an adequate number of ballot drop boxes can be challenging when you don't know how many voters will use them. And determining how many to obtain will be constrained by your budget, purchasing process, and ability to deploy multiple boxes before Election Day.

Hiring enough temporary workers to staff ballot security teams is another critical factor. To maintain public trust you should have bipartisan, two-person teams picking up ballots from each drop box on a daily basis. You will need more frequent pick-ups in the days leading up to and including Election Day. Early on, some busy locations may also require frequent pick-ups, perhaps multiple times a day.

The benefits to deploying as many ballot drop boxes as possible include:

- Providing greater access to the election process
- Keeping voters out of busy and stressful polling places on Election Day
- Receiving voted ballots back faster than USPS delivery

A rule of thumb to consider is one drop box for every 10,000-15,000 voters; that is a common requirement in states where mail ballots are the primary voting method. Your geography should also inform how many drop boxes to place. For example, rural, sparsely populated areas may require more drop boxes per capita than densely populated urban areas.

Fewer drop boxes will yield fewer benefits. An overflowing, unstaffed 24-hour ballot drop box can become a serious public relations and voter trust issue. If mailing out ballots is a temporary pandemic alternative, or if you don't have an adequate budget, temporary indoor ballot drop boxes at staffed locations can provide an adequate solution.

Scaling Up

Ballot drop boxes should be available to voters as soon as ballots are mailed and remain available through the close of polls on Election Day (or as the statute in your state provides). Unstaffed drop boxes are usually available 24 hours per day. Staffed drop boxes or drive-up options are

typically offered on a more limited schedule, such as during business hours and full polling hours on Election Day.

If adequate staffing is a problem, consider starting with fewer drop boxes and scaling up to the full number you need closer to Election Day. Note that scaling up over time presents P.R. challenges. You will need to clearly publicize drop box locations, plus the dates and times that each location is available.

Where Do I Place Them?

To choose ballot drop box locations, election officials should consider these factors at a minimum:

- Concentrations of population
- Concentrations of historically higher mail-voting populations
- Geographic distance and features
- Voter convenience
- Proximity to public transportation
- Community-based locations
- Security, including lighting, visibility, and security cameras

The Center for Tech and Civic Life (CTCL) created a [Ballot Drop-off Location Criteria Planner](#) to help jurisdictions evaluate potential ballot drop-off locations. The planner is located in Appendix B.

Unless prohibited by law, a staffed ballot drop box should be provided at every polling location. This will require separate drop boxes for mail ballots and in-person paper ballots (when not scanned at the polling location).

Additional locations for staffed drop boxes may include, but are not limited to: city offices, public libraries, county offices, assisted living facilities, senior living communities, college campuses, local businesses and shopping centers, and offices of community organizations. At these locations, the voter may need to leave their vehicle and enter the building. A drive-up option could allow voters to deposit their ballots and remain in their vehicles.

ADA Accessibility

Election officials should ensure that ballot drop box locations are accessible to voters with disabilities. Consider the following when implementing drop box plans.

1. If a location has only one drop box, the design and placement of that drop box should meet accessibility requirements.
2. If a location has more than one drop box, at least one of the drop boxes should meet accessibility requirements. Any inaccessible drop box at a facility should have a sign with directions to the nearest accessible drop box.
3. A drop box should be placed along an accessible path connected to the nearest ADA parking space, or nearest the passenger drop-off zone, and if applicable, the nearest public transportation stop.
4. If there is no accessible pathway from the parking lot, there should be signs directing the voter to the nearest accessible drop box.
5. Drop box locations inside of buildings should be assessed for accessibility as if they were polling places. For more information, please see the [ADA Checklist for Polling Places](#).

Purchasing Considerations

The type of ballot drop box(es) you use will depend on your plan and budget. Drop boxes come in several sizes, types, and different construction materials to with stand vandalism and inclement weather and to prevent removal. The following section will cover three types of ballot boxes: a 24-hour permanent box, a temporary indoor box and a temporary drive-through ballot drop-off.

24-Hour Unstaffed Ballot Drop Box

A 24-hour ballot drop box mimics a USPS blue mailbox. It is a permanent metal structure accessible by vehicle or on foot in the public right-of-way, and should be well-secured to the ground. Styles vary. These can be installed on your jurisdiction's property, or you can arrange to install one at a partnering public agency (see list in previous section.) This usually means securing a written agreement with property owners to locate and secure these drop boxes on their property before you purchase them. A list of drop box vendors is located in Appendix A.

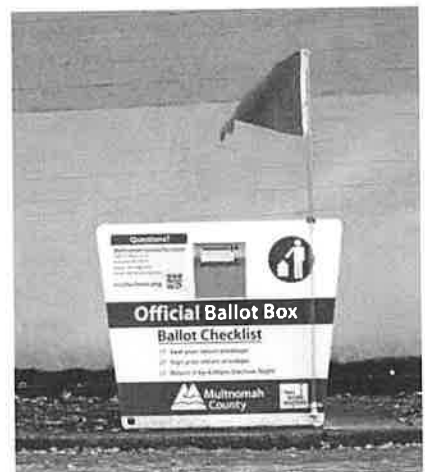

Some things to consider when purchasing 24-hour, unstaffed ballot drop boxes:

- The drop box should be a permanent fixture or a temporary structure that is secured in place to prevent removal or tampering.
- Ensure that the ballot drop box has robust locking mechanisms for both the ballot slot(s) and storage compartment. Ensure that ballots cannot be tampered with while in the drop box, nor removed by anyone other than your authorized ballot retrieval team.
- The opening slot should be large enough to deposit ballot envelopes and designed to keep anyone from pouring liquid into the drop box, or for rainwater to seep into it.
- Drop boxes should be easily recognizable by voters. Plan to purchase or produce permanent, large, weather-proof decals to label the drop boxes with at least your agency name, logo, phone number and the words *Official Ballot Drop Box*. Use consistent decals on all 24-hour boxes. Additional language may include:
 - *No Postage Required*
 - *Closes at 7 p.m. on Election Day* (or relevant time)
 - *This Box Under Video Surveillance* (if applicable)
 - If required, list any statutory language, such as the number of ballots that can be dropped off by one person in any election.
- Find out how many ballot envelopes each different brand or style of drop box can hold. Ballot return projections will help you to determine the drop box size you will need.
- Consider whether your jurisdiction can or must monitor the ballot drop box with 24/7 video surveillance, where the camera will be mounted, and how footage will be stored. If the drop box is located at another agency's facility, include mounting and access requirements in the agreement.
- If the ballot drop box is accessible by vehicle, consider whether you can safely locate it on the driver's side. This can ensure safety by letting the driver cast their ballot without exiting the vehicle. "One-Way" streets/thoroughfares are ideal for installing a box on the driver's side.
- When planning to receive a shipment of drop boxes, consider multiple important factors.
 - These drop boxes will arrive on pallets and are large and heavy.
 - They should be shipped to a warehouse.

- Installation may not take place immediately and you may need space to store them.
- A forklift may be needed to move them.
- While drop boxes have few moving parts, it is crucial that you verify the locks and doors are functioning properly and that all ballot slots are unobstructed before acceptance.

To install drop boxes you may need an agreement or permit from the local governing body before installing a drop box. Once an agreement and/or permit is secured, you may need to coordinate work with other offices to complete installation. Some items to consider:

- New concrete may need to be poured, which may extend the timeline for the boxes to be safe and fully functional.
- Consider drop box weight and bulk before shipping them out for installation. Consider which staff and vehicles are appropriate, and how the boxes will move in and out of the vehicle cargo area.
- Securing the boxes will require tradespeople whose schedules may not be flexible if shipment is delayed.
- Early and regular communications will help keep the team working together .

Temporary Ballot Drop Boxes — Indoors

Temporary indoor ballot drop boxes or bags are portable and much smaller than 24-hour drop boxes. Smaller options have handles on the side for carrying and are small enough to rest on a table. Larger options can hold more ballots and are on wheels. Bipartisan teams of two election workers usually monitor these drop boxes or bags.

Ideally, these drop boxes or bags should be available inside every polling place, to offer voters the greatest convenience for dropping off mail ballots. Ballot drop boxes placed inside the polling location may be serviced and staffed by poll workers rather than separate ballot collection teams.

They can also be located inside government buildings, libraries, community centers, and other high traffic areas. Your agency could secure an agreement to have staff from these partnering agencies monitor the drop box during their business hour and during polling hours on Election Day. The agreement should ensure access for your ballot retrieval team to pick up the ballot drop box or bag at scheduled times.

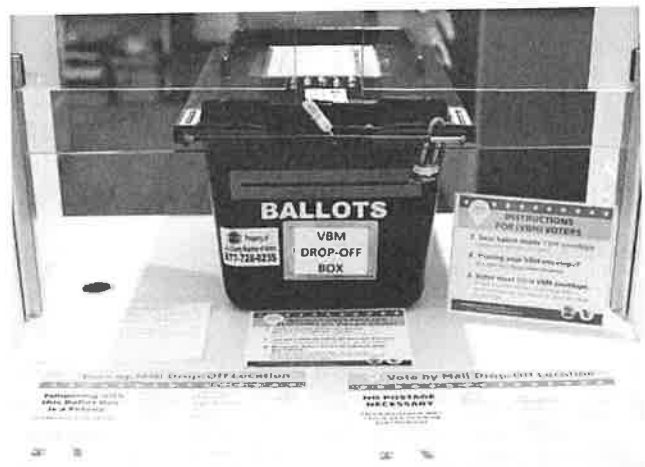

Factors to consider when purchasing temporary, indoor ballot drop boxes or bags:

- Consider durability, weight and sizing options, and which would be a better solution for your facility—a smaller, tabletop box, a bag, or a larger box on wheels.
- Determine how many ballots each drop box or bag can hold and your requirements for replacing or emptying it. Ballot drop boxes fill up quickly, especially approaching and on Election Day.
- Ensure that the drop box or bag cannot be opened or moved by unauthorized persons. It should have a lock to protect ballot envelopes, and ideally should be secured to an immovable object with a padlock or chain lock (such as a bicycle lock).
- Ensure that there is a place on the drop box or bag for a zip-tie style security seal for chain of custody.
- The drop box or bag should be easily recognizable by voters. Plan to purchase or produce decals to label it with your agency name, branding, the purpose of the drop box and useful information (see the section on Voter Outreach and Communication).

Temporary Ballot Drop Boxes — Drive Through

A drive-through ballot drop box is staffed by bipartisan teams of two election workers on a street or in a parking lot. These workers safely approach a vehicle, accept the voted ballot envelope from the voter, and deposit it into a ballot drop box while the voter observes. At minimum, these workers are equipped with safety vests and badges, a canopy tent for shelter, a table and chairs and locked ballot boxes. This option is usually only deployed on the last few days of the election, including Election Day.

Drive-through locations can be very convenient for voters as they do not need to park or exit their vehicles. They also offer greater operational efficiency for election administrators because they can absorb some of the traffic from high-demand, 24-hour ballot drop boxes on Election Day.

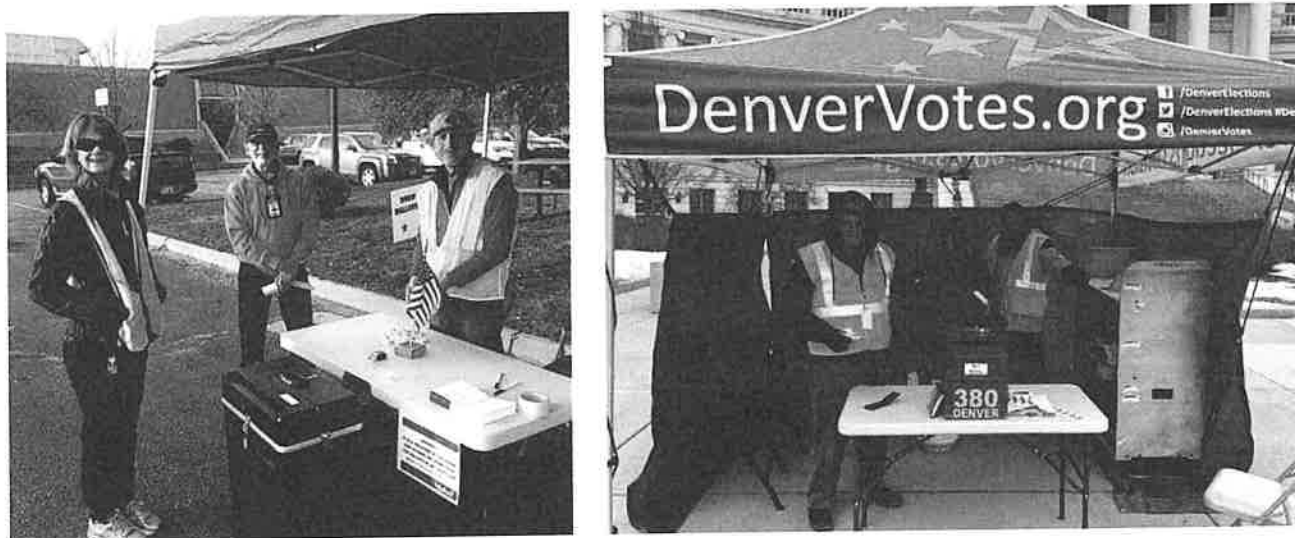

To avoid long lines of cars potentially blocking roadways and/or parking lots, ensure that you have enough staff and ballot drop boxes to move traffic through quickly. Also, some jurisdictions provide “I Voted” stickers at drive-through locations. While this can be a fun idea, it has the potential to slow the pace of cars through the process, creating longer lines. Be sure to consider this impact in your planning.

Some things to consider for temporary, drive-through drop off locations:

- To maximize safety and efficiency, provide instructions and maps to set-up teams. These should map out exactly where set-up should take place and how traffic should flow well in advance of deployment.

- Pop-up tents, tables, chairs, safety cones, and portable space heaters can often be borrowed from other government agencies (Sheriff's Office, Public Works, Parks & Recreation, Facilities or Fleet) or rented from a party or restaurant supply company.

Additional supplies are necessary for staff working outdoors, such as spotlights and flashlights for working in the dark, and apparel for inclement weather.

What Other Resources Will I Need?

Additional Supplies and Equipment for All Types of Ballot Drop Boxes

Bipartisan ballot retrieval teams

(Enough teams to ensure each drop box is closed/locked at “close of polls” on Election Night)

Phone tree to reach bipartisan teams while in the field

(May need to provide mobile phones for those who do not want to use their personal phones)

Rental cars or fleet vehicles

Chain of custody logs

Security seals

Portable ballot drop boxes or bags for transport

High-visibility vests for workers

Personal protective equipment such as gloves, masks, and hand sanitizer

Accessibility, directional, and electioneering signs (if applicable)

Temporary Indoor

Table(s)

Chairs

Cable or bike lock

Temporary Drive-Through

Table(s)

Chairs

Pop-up canopy

Road signs

Orange cones

Lanterns

Flashlights

Weather appropriate support such as propane heater and rain gear

Permanent 24-Hour

Extra keys made

Large mail bin placed inside

Flashlights

How Do We Secure Ballot Boxes?

The location and type of drop box can affect the security measures needed to ensure both actual and perceived security.

Locking Requirements

All drop boxes shall be secured by a lock and a tamper-evident seal. Only an election official and a designated ballot retriever shall have access to the keys and/or combination of the lock. If your drop box(es) are secured by a key lock, be sure to make copies of each key and store them securely at your election facility.

Video Requirements

If feasible, both temporary and 24-hour drop boxes should be monitored by a video security surveillance system, or an internal camera that can capture digital images and/or video.

A video security surveillance system is especially critical for unstaffed, 24-hour boxes and can include existing systems on county, city, or private buildings. The video system should be robust enough to capture and store video for the full time the ballot drop box(es) are open to receive ballots during an election. These videos may be considered an election record, and thus may need to be retained for a certain period of time after each election, depending on your state laws.

The easiest way to provide video surveillance is to position your ballot drop box within view of an existing video surveillance system. If you need to install your own system, work with your city/county IT, facilities, or law enforcement division to see if there are similar systems used throughout the city/county. Chances are your jurisdiction already has a vendor set up for this type of equipment.

Bipartisan Election Workers (drive-through locations)

Drive-through ballot drop boxes must be monitored very closely by election workers to ensure that someone does not drive-off with a ballot drop box.

Other Safety and Security Measures

Unstaffed drop boxes placed outdoors should be securely fastened to prevent moving or tampering. For example, fasten the drop box to concrete or an immovable object. This will prevent unauthorized removal of the drop box.

Staffed drop boxes have several options, but all options should take into consideration additional security measures when the ballot drop site is not staffed. Safeguarding the drop box during unstaffed hours could mean the drop box is inaccessible to the public when not in use. The box should be secured in a locked room, sealed with a tamper-evident seal, and if possible, under video surveillance. Staffed drop boxes should be securely fastened to a stationary surface or to an immovable object, and/or placed behind a counter, and/or portable so they can be transported to a curbside area or a mobile voting area. When in use, these drop boxes should be constantly monitored by election officials or other designated representatives.

Work with law enforcement to include frequent patrols of unstaffed drop boxes. In some communities, it might also be appropriate to develop a network of citizens willing to regularly patrol unstaffed drop boxes.

Work with the public works department and law enforcement to make drive through locations safe and secure.

Ballot Retrieval

Driving Routes, Frequency, and Staffing Needs

Once the locations of your ballot drop boxes are set, you should begin planning daily routes for ballot retrieval. This includes sending teams to visit all ballot drop boxes - permanent and temporary. The frequency of pickups may vary in the beginning, every other day versus every day, and become more frequent - multiple times per day - the closer you get to Election Day.

The time it takes to retrieve ballots will depend on the type of ballot drop box used. Ballot retrieval teams will be able to park close to most permanent, 24-hour drop boxes. They will need to transfer the contents of the drop boxes to portable bags or boxes, seal the boxes, complete their chain of custody paperwork, and load the portable boxes into a vehicle.

Temporary, staffed ballot drop boxes are usually located inside a building. This means ballot retrieval teams will need to park and walk into the building to the room where the temporary ballot drop box is located. Most often, they will switch out the full ballot drop box for an empty

drop box, complete the chain of custody paperwork, and carry the full drop box or bag back to their vehicle. The process for temporary drive-through locations will be similar.

Driving Routes

The process of retrieving ballots will be most efficient if retrieval teams are able to follow pre-planned driving routes. This can be made easier with mapping technology. Some election offices use commercial software such as Roulific and Esri Workforce. Google Maps is a free option that most staff will be familiar with and find easy to use.

When using Google Maps, begin by mapping out a route that you think can be completed in four hours. Identify each location, including the starting and ending location (typically the election office). Assume that the necessary steps at each location will take approximately 15 minutes to complete. Adjust the number of drop boxes on the route until you are able to achieve a route that can be completed in roughly four hours. Be sure to map it during the same times your retrieval team members will be on the road to account for daily traffic patterns. Also consider adding in break times as needed for your retrieval teams.

Consider using mobile phone tracking applications or GPS spot trackers as a way to ensure the assigned route is followed without deviation and that your retrieval team is on time. This may also help document your chain of custody.

Frequency of Retrieval

The frequency with which you retrieve ballots from each ballot drop box depends on multiple factors, including:

- Timing (How close to Election Day is it?)
- Projected and actual voter turnout
- The number of ballot boxes you have
- How many ballots each box can hold
- The geography of your jurisdiction and distance retrieval teams have to travel

Generally, it is important to retrieve ballots at least once per day from the first day ballots may be returned. This will ensure ballot security and the ballots can enter your processing operation as quickly as possible. From there, structure your retrieval plan around a slowly building stream of ballots. Jurisdictions have seen as few as 20% of ballots cast by mail deposited in drop boxes during the first two weeks and as many as 55%–60% of ballots deposited during the last two days

of the election, including 40% of ballots cast on Election Day. You will need to retrieve ballots multiple times per day from your busier ballot drop boxes the closer you get to and on Election Day.

Other important items to consider when creating your retrieval plan:

- Your plan needs to be flexible. If voter turnout is higher than anticipated, you may need to retrieve ballots multiple times per day sooner than you had planned to scale up.
- On the Monday evening before Election Day, you must retrieve ballots from all drop boxes at the end of the day so they do not fill overnight and to maximize the number of ballots you can count on Election Day.
- On Election Night, you must close all drop boxes simultaneously with closing the polls. This will take significant staffing and coordination.
- It is important to track as much data about this process as possible. Retain it for future planning, including how many ballots you retrieve from each drop box each day and how many retrieval runs were needed to each drop box each day. This data can be obtained from ballot logs and reviewed after the election.

Staffing Needs

Use the mapped driving routes and frequency of retrieval to determine how many teams and vehicles you will need and for how long. For example, in the first few weeks after ballots are mailed out you might only need three teams of two (six temporary workers) and three vehicles. That number might increase significantly or even double as you start the week leading up to Election Day.

The biggest staffing challenge for ballot retrieval will be at the close of polls on Election Night. You will need bipartisan teams to close and seal each ballot drop box right at the close of polls (or as the statute in your state provides). Many jurisdictions recruit staff from sister agencies, since drop box closing teams do not require full poll worker training. Remember, these ballot retrieval teams will need to be bipartisan, even those staff recruited from other agencies, and may need to be sworn in as election workers.

As mentioned in the overview, accommodations for COVID-19 and the need for social distancing will affect your staffing decisions. Asking two unrelated workers to drive together in the same car may be a challenge. You will need to accommodate any retrieval team member requests to travel in separate cars in tandem. The steps for setup and the daily retrieval of ballots should also follow the six-foot distancing requirements.

Voter Outreach and Communication

Promoting the use and availability of ballot drop boxes is essential to their success. Use all of the communication tools and resources at your disposal as soon as practical to publicize ballot drop box locations, hours and notable accessibility features.

For example, use your regular print and electronic materials, website, social media, video, and news releases to announce ballot drop box locations and share a link to a comprehensive list and/or map of ballot drop boxes.

You can also include a list of ballot drop-off locations in your **mail ballot instructions**, **voter information guide** and **sample ballot publications**. Depending on how many locations you have, you may be able to print them on the mail ballot envelope as well. If there are too many locations to fit, perhaps include a link or QR code on the envelope to direct voters to your list of locations.

Your election website will be the optimal resource for voters to find a ballot drop-off location. Create a **web page for Ballot Drop-Off Locations**. Include a list of all location names, addresses, hours and embed a link to a Google map for each. If there is a change to the ballot drop box plan, it should be noted on your official website within 24 hours.

You can also create and embed a **map of all ballot box locations** using Google My Maps. First, create a list of locations as a .csv file, with separate columns for location name, address, city, state and zip code, hours, and type of ballot drop box. Then visit www.google.com/mymaps and follow instructions to import the map. You'll need to create a Google account if you don't already have one.

Issue a **news release and photos** if you have installed one or more new 24-hour ballot drop boxes in your community. Share it with your own employee news channels, local news media, as well as jurisdictions for newsletters and public television news shows.

Ask the clerk or communications team in your local cities and towns if you can submit a **contributed article** for their newsletter, blog or website regarding the election. Be sure to request a deadline and word count. Describe options for voters and indicate where citizens within your jurisdiction can find their nearest ballot drop box and polling place. You can also ask them to embed your election page link on their own webpages.

Another creative idea is to develop a **'Find My Nearest' web-based tool** to help voters find the ballot drop box that is closest to them. A user will type in an address or allow the tool to use their device's 'location services' to identify their current location. The tool would then populate with a map and list of the nearest three or four ballot drop off locations. This will require knowledge of ArcGIS or Google Maps, and will likely require support from your IT department to create.

Execution

Opening and Setup

Whether you are setting up a temporary ballot drop box or a 24-hour location, you will need to plan for a ballot retrieval team to set up, open, and secure the drop boxes for voters to deposit their voted ballots.

Temporary Ballot Drop Boxes

Supplies:

- Locked and sealed ballot drop boxes or bags
- Tamper-evident seals (if replacements are needed)
- Chain of custody logs
- Phone numbers to call for support/emergencies
- Cable or bike lock
- Applicable signage
- Tables and chairs (if necessary)
- "I Voted" stickers (optional)
- Voter information sheet (optional)
- Voter Registration forms (optional)

Voter information sheets, "I Voted" stickers, and other voting related information may be placed near the drop box.

Drive-Through Ballot Drop Boxes

Drive-through ballot drop boxes might be set up in a parking lot or on the street depending on the location. For all street-related setups, there should be a law enforcement officer present to guide the setup and maintain safety throughout the day.

When setting up in a parking lot, consider the use of “no parking” signs. These signs can be left out overnight to ensure no vehicles park in the area to be used for the drive-through location.

Supplies should be delivered, including:

- Locked and sealed ballot drop boxes or bags
- Tamper-evident seals
- Chain of custody logs
- Phone numbers to call for support/emergencies
- Set-up maps/documentation
- Pop-up tent
- Road signs
- Orange cones
- Table and chairs
- “I Voted” stickers (optional)
- Propane heater (optional during cold weather months)
- Flashlights or lanterns

Bipartisan teams should:

1. Position road signs and cones according to provided map or instructions.
2. Set up the tent and position according to the provided map or instructions.
3. Set up the folding table and chairs.
4. Place the ballot drop box on the table.
5. Set up the heater and propane tank if needed

24-Hour Ballot Drop Boxes

Permanent, 24-hour drop boxes should be available for voters to use as soon as ballots are mailed. This requires staff or ballot retrieval teams to inspect, clean, and open the ballot drop slot on each drop box. An assigned route for opening should be created along with a checklist or log to ensure all ballot drop boxes have been opened.

Each retrieval team will need:

- Slot key
- Access door key
- Phone numbers to call for support/emergencies
- Cleaning supplies
- Silicone spray (for locks)
- Flashlight
- Inspection checklist or chain of custody form

For setup and opening of 24-hour ballot drop boxes, retrieval teams will:

1 Unlock	<input type="checkbox"/> Open the ballot slot, using the slot key. <input type="checkbox"/> Open the access door, using the access door key.
2 Inspect and Clean	<input type="checkbox"/> Visually inspect the drop box and surrounding areas. <input type="checkbox"/> If there is any graffiti or wrap damage, the retrieval team will clean or repair as best they can. <i>If unable to clean or repair it thoroughly, use mobile phone to take pictures and note the damage on the chain of custody form</i> <input type="checkbox"/> Wipe down the exterior, top and slot area of the drop box. <input type="checkbox"/> Spray the locks with silicone spray and ensure they can be easily locked and unlocked. <input type="checkbox"/> Both retrieval team members visually inspect the drop box interior for ballots or any type of debris. <input type="checkbox"/> Use a mobile phone to take a picture as time-stamped proof the ballot drop box is empty.
3 Seal and Record	<input type="checkbox"/> Close and lock the access door using the access door key. <input type="checkbox"/> Place a security seal on the access door and record seal number on a chain of custody form. <input type="checkbox"/> Complete and sign the retrieval form or chain of custody form.

Daily Collection of Ballot Drop Boxes

- Only designated bipartisan ballot retrieval teams should remove ballots from drop boxes. This is done in teams of two.
- All designated ballot retrieval team members should wear badges or vests that readily identify them as designated ballot retrievers or election officials.
- Each team of two will be provided a route each day.
- Ballots must be picked up in designated order.
- A separate chain of custody form should be completed at every stop (both for 24-hour drop boxes and temporary drop boxes or bags).
- The ballot retrieval log and checklist should be completed at the beginning of the route, at each stop, and after returning to the election office.
- Visually inspect the drop box and surrounding area at each visit. If there are any signs of tampering or vandalism, take pictures, clean or repair the drop box as best you can, and report in the notes section of the chain of custody form.















Instructions for Completing Ballot Retrieval Log

- On the front, record the date and time and check off all supplies that have been retrieved.
- On the back, record the route number, date, and names of both ballot retrievers.
- After ballots have been retrieved at each stop, record:
 - Column A: Name/ID/location of the ballot drop box
 - Column B: Seal number on the door (24-hour drop box) when you arrived (should be affixed to custody log) or the security seal on the temporary drop box you are retrieving
 - Column C: Seal number attached to each transfer box or bag (only for 24-hour drop box)
 - Column D: New seal number put on the door (24-hour drop box) or the seal number for the replacement temporary box or bag
 - Column E: Current time of day
 - Column F: Initials of each ballot retrieval team member.

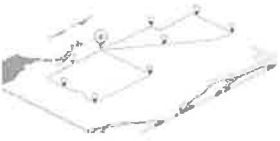
- At the conclusion of each route, the bottom portion of the form should be completed. Consider using the same visual checklist of supplies to indicate all supplies and equipment have been returned to the election office.

Ballot Retrieval Team Daily Log *(front)*

Date: _____ Route Departure Time: _____ : _____ AM PM

 <p><input type="checkbox"/> Access door or padlock keys</p>	 <p><input type="checkbox"/> Empty, portable ballot box(es)</p>	 <p><input type="checkbox"/> Flashlight</p>	 <p><input type="checkbox"/> High-visibility vests</p>
 <p><input type="checkbox"/> Cleaning supplies</p>	 <p><input type="checkbox"/> Gloves</p>	 <p><input type="checkbox"/> Masks</p>	 <p><input type="checkbox"/> Hand sanitizer</p>
 <p><input type="checkbox"/> Chain of custody logs</p>	 <p><input type="checkbox"/> Driving route and map</p>	 <p><input type="checkbox"/> Pens</p>	 <p><input type="checkbox"/> Vehicle keys</p>
 <p><input type="checkbox"/> Clipboard</p>	 <p><input type="checkbox"/> 24-hour drop box security seals</p>	 <p><input type="checkbox"/> Transfer ballot box or bag security seals</p>	 <p><input type="checkbox"/> Mobile phone and charger</p>
<p>Route Return Time: _____ : _____ <input type="checkbox"/> AM <input type="checkbox"/> PM <input type="checkbox"/> Supplies <input type="checkbox"/> Vehicle Keys</p>			

Ballot Retrieval Team Daily Log *(back)*

Route ID# _____

Date: _____		Retriever 1: _____		Retriever 2: _____		
A Drop Box Name/ID	B Existing Seal ID	C Transfer Box/Bag Seal	D New Seal ID	E Collection Time	F Team Initials	

Ballot Retrieval Team Chain of Custody Record

Ballot Drop Box Name/#:	Date:
Retrieval Team Member 1:	Retrieval Team Member 2:
Transfer Box/ Bag #:	Additional Transfer Box/Bag #:

Time of Arrival: <input type="checkbox"/> AM <input type="checkbox"/> PM	Initials:	PLACE USED SECURITY SEAL
Security Seal Intact: <input type="checkbox"/> YES <input type="checkbox"/> NO	Initials:	
Remove security seal and record seal #:		

<input type="checkbox"/> Inspect ballot drop box for any signs of tampering or vandalism. <input type="checkbox"/> Unlock the access door and remove ballots. <input type="checkbox"/> Transfer ballots to ballot transfer box or bag. <input type="checkbox"/> Inspect inside of drop box for ballots that might be leaning against or stuck to the wall. <input type="checkbox"/> Inspect drop box area to ensure no ballots have fallen on the ground. <input type="checkbox"/> Seal the ballot transfer box or bag. <input type="checkbox"/> Record the transfer box or bag seal number(s). Seal #: _____ Seal #: _____ Seal #: _____ Seal #: _____	
<input type="checkbox"/> Verify access door is closed and locked (checked by both team members). <input type="checkbox"/> Place new security seal on door. <input type="checkbox"/> Record new security seal placed on door: Seal #: _____ <input type="checkbox"/> Load transfer containers into vehicle. <input type="checkbox"/> Record new door security seal and transfer security seal numbers on the ballot retrieval log.	

All procedures completed and recorded: <input type="checkbox"/> YES <input type="checkbox"/> NO	Initials:
Service Required? <input type="checkbox"/> YES <input type="checkbox"/> NO	Notes:
Time of Departure: <input type="checkbox"/> AM <input type="checkbox"/> PM	Initials:

Election Night Closing

All ballot drop boxes, temporary and permanent, need to be collected or closed at the time the polls close. The process outlined below is focused on permanent, 24-hour drop boxes, but the same general principles can be applied to temporary ballot drop boxes. These instructions can be supplemented with the Election Night Closing Checklist that follows.

Station a bipartisan retrieval team at each drop box 15 minutes before the polls close. They will lock drop boxes as soon as the polls close and retrieve ballots.

- Consider asking other jurisdictions' employees to assist, since this process does not require a great deal of training. Provide each retrieval team with the necessary supplies and checklist as detailed in this guide. In addition to those supplies, these retrieval teams will also need the following:
 - Map with driving directions and approximate time it will take to arrive at their location. This ensures they leave the election facility with enough time to arrive 15 minutes before the close of the election.
 - "Last Voter in Line" card
 - Extra transfer ballot box or bag to collect ballots cast after the polls close. These ballots will not be counted. These are ballots from voters not in line at the time polls close, but who approach the box as the retrieval team is transferring ballots.
 - Checklist with instructions for completing a full sweep of the drop box with a flashlight along with instructions for locking, sealing, recording, transferring ballots to a temporary box, taking a photo and returning to HQ.
- You may have a line of people, or cars, at close of polls with people waiting to cast their ballot in the drop box. As with in-person voting, have one person walk to the end of the line of people and/or cars and hand the last voter in line at close of polls the "Last Voter In Line" card to ensure everyone in line at close of polls may cast their ballot.
- Instructions for how to handle a line of cars (if 24-hour drop box or drive-through ballot drop-off) or a line of people (if temporary indoor drop box). This should include a "Last Voter in Line" card and potentially coordinating with local law enforcement for traffic control.

- Recommend teams take pictures of:

- Locked ballot slot
- Inside of the 24-hour boxes once emptied after the close of polls to show that no ballots are left in the box.

It is highly recommended to have your daily ballot retrieval team visit all ballot drop boxes the day after the election to double-check that all ballots were collected.

Election Night Closing Checklist

Ballot Drop Box Name/#:	Date:
Retrieval Team Member 1:	Retrieval Team Member 2:

- Ensure you have necessary supplies and chain of custody logs before leaving for your designated drop box.
- Ensure you take enough transfer boxes or bags to completely empty the drop box.
- Arrive at your assigned ballot drop box at least 15 minutes early.
- If there is a line before polls close, one retrieval team member must find the "Last Voter In Line" card and go to the end of the line.
- At the close of polls, announce "Polls are closed" and lock the door to the drop box. If there is a line, the team member at the end of the line should give the Last Voter In Line card to the last person or car in line at the close of polls. Once the card is given out, return immediately to help empty the drop box.
- If any voter should try and cast their ballot after the close of polls, put their ballot in the box/bag designated for late ballots.
- Unlock the access door and remove all ballots, placing them in a transfer box or bag.
- Using a flashlight, inspect the inside of the drop box for ballots that might be leaning against or stuck to the wall.
- Once all ballots are removed from the drop box, take a picture of the inside of the empty drop box using your phone.
- Inspect the drop box area to ensure no ballots have fallen on the ground.
- Seal the ballot transfer box(es)/bag(s).
- Verify the access door of the drop box is closed and locked.
- Close the ballot slot using the slot key.
- Complete Chain of Custody log(s) for the transfer box(es) or bag(s).
- Load transfer containers and all supplies into vehicle.
- Head directly back to counting facility.

All procedures completed and recorded:	<input type="checkbox"/> YES <input type="checkbox"/> NO	Initials:
Time of Departure:	<input type="checkbox"/> AM <input type="checkbox"/> PM	Initials:

Common Mistakes and How to Prevent Them

Problem: Drop boxes left unsealed or unlocked

Solution: Checklist that is signed or initialed for each drop box and verified at the end of every shift

Problem: 24-hour drop boxes left open or unlocked

Solution: Checklist that is signed or initialed for each drop box and verified at the end of every shift

Problem: Drop boxes are full before Election Day and voters are leaving ballots on top, calling news media, etc.

Solution: Increase the number of pickup times as you get closer to Election Day

Problem: Drop boxes not closed at 7 p.m.

Solution: Send retrieval teams out to sweep boxes the day after the election to ensure no ballots are left behind (perhaps take photos)

Appendix A: Drop Box Vendors

This list was compiled by the Center for Tech and Civic Life.

Laserfab, Inc/Vote Armor

www.laserfabusa.com

Models:

- VA-3630 is the most popular
- The largest model, the VA-5038, is used by larger counties
- A third model exists, but no model number was provided

Approximate pricing: The 3630 model runs in between \$3000 and \$3500, depending on quantity.

Timeline: 6-8 weeks from order

American Security Cabinets

www.ballotdrops.com

Models:

- 7 different sizes and styles: <https://ballotdrops.com/product-category/cabinets/>

Approximate pricing: Please inquire

Timeline: Please inquire

Fort Knox Mailbox

www.fortknoxmailbox.com

Models: High Security Mailboxes - Fort Knox Mailbox, LLC.

- 3 different sizes: <https://www.fortknoxmailbox.com/ballot-boxes/>

Approximate pricing: \$1,300 - \$3,000 each, depending on model

Timeline: Please inquire

Inclusion Solutions

www.inclusionsolutions.com/wp-content/uploads/2019/06/IScatalog2019v8.pdf (pages 12-13)

Models:

- Fortress 400 ideal for indoor use, holds 400 ballots
- Fortress 800 ideal for indoor use, holds 800 ballots
- Fortress 1000 can transition to indoor & outdoor, holds 1,000 ballots

Approximate pricing: Fortress 400 is \$130, Fortress 800 is \$209, call for info about Fortress 1000

Timeline: Please inquire

Charnstrom

www.charnstrom.com

Models: Four models of “payment cabinets” and “Mail Collection boxes”, ranging in size.

- Small: \$420 - Commercial/Residential Curbside Mailbox (13”W x 18” D x 20”H)
- Large: \$3,608 - Mail Room/Office Mailing Walk or Drive up Box. Holds “hundreds of envelopes and magazines”. (24”W x 29.5” D x 53” H)

Pricing: \$400 to \$4000

Timeline: Please inquire

Global Industrial

www.globalindustrial.com

Models: Mail & Parcel Drop Boxes

- Drop Box Locker: \$450 - \$1,513 (12”W x 12”D x 16.5”H)
- Supreme Letter Locker: \$475 - \$2,283 (12”W x 23”D x 24-36”H)
- Extra Large Mailbox & Parcel Post Vault: \$883 (19”W x 19”D x 52”H)
- Curbside Courier & Collection Box: \$759 - \$967 (20”W x 26”D x 49”H)

Pricing: \$350 to \$2,300 depending on model

Timeline: UPS Next Day, UPS 2nd Day, UPS or Truck 3-8 days shipping

U. S. Mail Supply

www.USMailSupply.com

Models: Some examples

- Small Versatile Pedestal Hopper Collection Box \$1,175 (17.75" L x 18.75"W x 59" H)
- Courier Drop Box \$780 (20"W x 49"H x 26"D)
- All Weather Sealed Outdoor Collection Box \$1,065 (22-1/4"W x 22-1/4"D x 47"H)

Pricing: Varies, depending on model

Timeline: Please inquire

Appendix B: Site Feasibility Planner

See following pages.

Deanna Debruler

From: Hillary Hall <hillary@voteathome.org>
Sent: Friday, October 9, 2020 5:45 PM
To: Ryan Chew
Cc: Celestine Jeffreys; Dayna Causby; Kris Teske; Michael Spitzer-Rubenstein
Subject: Re: Green Bay w EG & VAH @ Fri, Oct 9, 2020 5:00pm – 6:00pm (GMT-04)

Thanks for the guide Danya and thanks for the additional information Ryan.

Yes it would be interesting if the way they address consistency is by handling all of this things in a recount.

On Fri, Oct 9, 2020 at 4:39 PM Ryan Chew <ryan@electionsgroup.com> wrote:
At one point, that guide refers to the Election Day Manual for Election Officials (which is an encompassing term in WI that includes poll workers.)

There I find an answer to one of today's questions there:
>

Any observer who is a qualified elector of Wisconsin, including an election inspector can challenge an absentee elector's ballot the same as if the elector were voting in person. The procedures for challenging an elector's ballot are the same as the challenge procedure in person. See the "Challenging Electors" section of this manual for the complete challenge procedure.

I see no reference to other situations than overvoted ballots in the Manual. It would be interesting to know whether the WEC sets percentage thresholds for a mark to be ignored, adjudicated or counted, or whether it's up to the jurisdiction.

Ryan
The Elections Group
312 823-3384

On Fri, Oct 9, 2020 at 5:10 PM Dayna Causby <dayna@electionsgroup.com> wrote:
2018 voter intent publication

https://elections.wi.gov/sites/default/files/publication/65/counting_spring_pri_gen_elections_rev_2018_02_p14494.pdf

--
Thank you,

That would be fine, I have a phone call at 1:30 and am free between 2:15 and 3:30.

We are working with Eric from Modern Elections and have put out an RFP to engage a public affairs firm. We anticipate hiring a firm by mid-September.



Celestine

Jeffreys

Chief of Staff

Office of the Mayor

920.448.3006

From: Dayna Causby <dayna@electionsgroup.com>

Sent: Monday, August 31, 2020 9:52 AM

To: Celestine Jeffreys <Celestine.Jeffreys@greenbaywi.gov>; Kris Teske <Kris.Teske@greenbaywi.gov>;
Ryan Chew <ryan@electionsgroup.com>

Subject: Proposed meeting

All,

I would like to set up time today after 1 CT to talk about communication plans around election results expectations for critical stakeholders and the general public. Is there a time that isn't good?

Thank you,

Dayna Causby, CERA

The Elections Group

"Voting is the expression of our commitment to ourselves, one another, this country and this world"

~Sharon Salzberg

--
Thank you,
Dayna Causby, CERA
The Elections Group

"Voting is the expression of our commitment to ourselves, one another, this country and this world"
~Sharon Salzberg

Deanna Debruler

From: Kris Teske
Sent: Friday, October 9, 2020 2:09 PM
To: Celestine Jeffreys
Subject: RE: Cure process question

Please send me Julie Emery's email.

Thank you,

Kris Teske, WCMC
Green Bay City Clerk
100 N. Jefferson St., Rm 106
Green Bay, WI 54301
920-448-3014



From: Celestine Jeffreys [mailto:Celestine.Jeffreys@greenbaywi.gov]
Sent: Thursday, October 8, 2020 8:43 PM
To: Kris Teske <Kris.Teske@greenbaywi.gov>
Subject: FW: Cure process question

This is one of the inquiries about curing.

Celestine Jeffreys
Chief of Staff, Mayor's Office
City of Green Bay

From: Anjali Bhasin <anjali@conservationvoices.org>
Sent: Monday, October 5, 2020 7:47 PM
To: Celestine Jeffreys <Celestine.Jeffreys@greenbaywi.gov>
Subject: Re: Cure process question

Hi Celestine,

Julie actually works for a different organization. I work with Wisconsin Conservation Voices which is the C3 partner of Wisconsin Conservation Voters. Seth Hoffmeister and Casey Hicks are my colleagues. I would be happy to set up a time to talk. I am free tomorrow from 12:00-1:30p.m. or 3:30-5:30p.m. I can also talk on Wednesday from 3:30-5:00p.m. Would any of those work for you? If not, are there other times that would?

Best,
Anjali

On Mon, Oct 5, 2020 at 1:16 PM Celestine Jeffreys <Celestine.Jeffreys@greenbaywi.gov> wrote:

Anjali,

I believe I've communicated with one of your co-workers, a Julie Emery. See her email below. She and I weren't successful in setting up a time to talk. Perhaps we can set up a time to discuss?

Celestine,

We're working on making sure we are sharing the most accurate information possible with voters in our voter education programs this year.

Can you share with me what the ballot curing process looks like both for absentee ballots you receive between now and election day and for ballots cast or opened on election day?

Thank you for your help.

--

Julie Emery

Outreach Director

Wisconsin Voices

540-270-2742 (Mobile)



Celestine Jeffreys

Chief of Staff

Office of the Mayor

920.448.3006

From: Anjali Bhasin <anjali@conservationvoices.org>

Sent: Monday, October 05, 2020 12:36 PM

To: Celestine Jeffreys <Celestine.Jeffreys@greenbaywi.gov>; Amaad Rivera <Amaad.Rivera@greenbaywi.gov>

Subject: Cure process question

Hi Amaad and Celestine,

I hope you are both doing well. I was writing because I had a few questions in terms of the election and the cure process.

More specifically, I was wondering if Green Bay is going to allow voters to fix mistakes on their ballots. If so, do you know what that process will look like and if you need any help with outreach to voters?

I hope you are both well.

Best,

Anjali

--

Anjali Bhasin

Civic Engagement Director

Wisconsin Conservation Voices

She/her/hers

anjali@conservationvoices.org

--

Anjali Bhasin

Civic Engagement Director

Wisconsin Conservation Voices

She/her/hers

anjali@conservationvoices.org

--

Anjali Bhasin

Civic Engagement Director

Wisconsin Conservation Voices

She/her/hers

anjali@conservationvoices.org

Deanna Debruler

From: Jaime Fuge
Sent: Monday, November 2, 2020 7:34 AM
To: Saralynn Finn
Cc: michael@voteathome.org
Subject: RE: Central Count Ballot Tracking Sheets

This is very helpful.

Thank you!

From: Saralynn Finn [mailto:saralynn@voteathome.org]
Sent: Saturday, October 31, 2020 10:31 PM
To: Michael Spitzer-Rubenstein <michael@voteathome.org>
Cc: Jaime Fuge <Jaime.Fuge@greenbaywi.gov>
Subject: Re: Central Count Ballot Tracking Sheets

Yes, here is the document I made to hand out to central count observers.
I can send you an editable version if you need or try and make any changes you want.
Best,
Saralynn

On Sat, Oct 31, 2020 at 4:35 PM Michael Spitzer-Rubenstein <michael@voteathome.org> wrote:

Saralynn, you've been working on observers. Do you have a good guide for questions they're likely to ask & answers?

Also, Jaime, just to follow up on the call and this email, would you prefer doing a cover sheet like what we created before (travels with the batch of ballots) or a log like what Milwaukee uses (sits at the table)?

Can talk about it tomorrow or even Monday. Will just be a minor tweak of the instructions either way.

Michael

On Sat, Oct 31, 2020 at 4:27 PM Jaime Fuge <Jaime.Fuge@greenbaywi.gov> wrote:

Hi,

I do have a followup question that came to my mind. What are some of the common questions the observers ask. We have not really have observers that have asked many questions prior.

Thank you,

Jaime



From: Celestine Jeffreys [<mailto:Celestine.Jeffreys@greenbaywi.gov>]
Sent: Thursday, October 1, 2020 6:32 AM
To: Calvin Winters <Calvin.Winters@greenbaywi.gov>
Cc: Michael Spitzer-Rubenstein <michael@voteathome.org>
Subject: type of ballot opener

Calvin,

Can you tell Michael Spitzer-Rubenstein (one of our Election Grant Mentors) what type of ballot opener we purchased? This will help him make some calculations about Central Count.

Thanks!!

Celestine Jeffreys

Chief of Staff, Mayor's Office

City of Green Bay

--
Michael Spitzer-Rubenstein
State Lead for Wisconsin (Leadership Now Fellow)
National Vote at Home Institute
(310) 980-2872
he/him



Learn more about:
[Election Officials Center](#)
[Mail Ballot FAQs](#)
[Mail Ballot Security](#)

Deanna Debruler

From: Michael Spitzer-Rubenstein <michael@voteathome.org>
Sent: Thursday, October 1, 2020 7:43 AM
To: Celestine Jeffreys
Cc: Calvin Winters
Subject: Re: type of ballot opener

Great, thanks!

On Thu, Oct 1, 2020 at 8:10 AM Celestine Jeffreys <Celestine.Jeffreys@greenbaywi.gov> wrote:

Thanks, Calvin!

Celestine Jeffreys

Chief of Staff, Mayor's Office

City of Green Bay

From: Calvin Winters <Calvin.Winters@greenbaywi.gov>
Sent: Thursday, October 1, 2020 7:10 AM
To: Celestine Jeffreys <Celestine.Jeffreys@greenbaywi.gov>
Cc: Michael Spitzer-Rubenstein <michael@voteathome.org>
Subject: RE: type of ballot opener

We purchased 3 Martin Yale 62001 openers in addition to the one opener we already had.

Calvin Winters

Procurement Manager

City of Green Bay

Ph: (920) 448-3048

Fax (920) 448-3050

Calvin.Winters@greenbaywi.gov

The grant mentors would like to meet with you to discuss, further, the ballot curing process. Please let them know when you're available.

Celestine Jeffreys
Chief of Staff, Mayor's Office
City of Green Bay

From: Michael Spitzer-Rubenstein <michael@voteathome.org>
Sent: Friday, October 2, 2020 5:23 PM
To: Celestine Jeffreys <Celestine.Jeffreys@greenbaywi.gov>
Subject: Meet Next Week? Ballot Curing

Celestine,
Could we meet next week with someone in the clerk's office to go over ballot curing and adding a call operation?

Wednesday (any time after 10 AM) would work best for me. If that doesn't work, can do Tuesday (10-2) or Thursday (before 1 PM).

If you have a letter that goes out with rejected ballots, could you send that? (If not, I can create one).

I'm going to put together a process document, phone script, and job description/simple RFP—could either hire a firm or a few individuals to do the calls.

Thanks and enjoy your weekend,
Michael

Michael Spitzer-Rubenstein
State Lead for Wisconsin (Leadership Now Fellow)
National Vote at Home Institute
(310) 980-2872
he/him



Learn more about:
[Election Officials Center](#)
[Mail Ballot FAQs](#)
[Mail Ballot Security](#)

Deanna Debruler

From: Kris Teske
Sent: Tuesday, October 13, 2020 1:38 PM
To: Michael Spitzer-Rubenstein
Subject: RE: In Wisconsin, Meet Friday?

Thanks for the guide.

City Hall is only open to staff and the public by appointment but thank you for the offer.

Kris Teske, WCMC
Green Bay City Clerk
100 N. Jefferson St., Rm 106
Green Bay, WI 54301
920-448-3014



From: Michael Spitzer-Rubenstein [mailto:michael@voteathome.org]
Sent: Friday, October 9, 2020 3:58 PM
To: Kris Teske <Kris.Teske@greenbaywi.gov>
Subject: In Wisconsin, Meet Friday?

Kris,

I wanted to share a [guide on transparency for election officials](#) we put together with the Carter Center, featured in the Electionline weekly yesterday. I hope it might be useful for you.

I'll also be in Wisconsin starting next week; can I stop by your office next Friday? I'm happy to lend a hand. For instance, I'm helping Milwaukee assign inspectors to Central Count stations as well as polling places; happy to do the same for you.

Thanks and have a good weekend,
Michael

--

Michael Spitzer-Rubenstein
State Lead for Wisconsin (Leadership Now Fellow)
National Vote at Home Institute
(310) 980-2872
he/him



Learn more about:
[Election Officials Center](#)
[Mail Ballot FAQs](#)

Deanna Debruler

From: Jaime Fuge
Sent: Monday, November 2, 2020 7:34 AM
To: Saralynn Finn
Cc: michael@voteathome.org
Subject: RE: Central Count Ballot Tracking Sheets

This is very helpful.

Thank you!

From: Saralynn Finn [mailto:saralynn@voteathome.org]
Sent: Saturday, October 31, 2020 10:31 PM
To: Michael Spitzer-Rubenstein <michael@voteathome.org>
Cc: Jaime Fuge <Jaime.Fuge@greenbaywi.gov>
Subject: Re: Central Count Ballot Tracking Sheets

Yes, here is the document I made to hand out to central count observers.
I can send you an editable version if you need or try and make any changes you want.
Best,
Saralynn

On Sat, Oct 31, 2020 at 4:35 PM Michael Spitzer-Rubenstein <michael@voteathome.org> wrote:
Saralynn, you've been working on observers. Do you have a good guide for questions they're likely to ask & answers?

Also, Jaime, just to follow up on the call and this email, would you prefer doing a cover sheet like what we created before (travels with the batch of ballots) or a log like what Milwaukee uses (sits at the table)?

Can talk about it tomorrow or even Monday. Will just be a minor tweak of the instructions either way.

Michael

On Sat, Oct 31, 2020 at 4:27 PM Jaime Fuge <Jaime.Fuge@greenbaywi.gov> wrote:

Hi,

I do have a followup question that came to my mind. What are some of the common questions the observers ask. We have not really have observers that have asked many questions prior.

Thank you,

Jaime

From: Michael Spitzer-Rubenstein [mailto:michael@voteathome.org]

Sent: Friday, October 30, 2020 10:24 PM

To: Celestine Jeffreys <Celestine.Jeffreys@greenbaywi.gov>; Jaime Fuge <Jaime.Fuge@greenbaywi.gov>; Amaad Rivera <Amaad.Rivera@greenbaywi.gov>; Kim Wayte <Kim.Wayte@greenbaywi.gov>

Subject: Central Count Ballot Tracking Sheets

Hi all,

Sharing the updated versions of the ballot tracking sheets for Central Count:

1. Courier log for City Hall to KI (adjusting the dropbox log)
2. Processing cover sheet (for tracking a batch of ballots from a single ward into the DS450)
3. Reconstruction cover sheet (for tracking ballots that need remaking in a single batch across many wards)

Since we have the processes nailed down and I understand it all now, I'm going to work on the training manual tomorrow.

See you tomorrow,

Michael

--

Michael Spitzer-Rubenstein

State Lead for Wisconsin (Leadership Now Fellow)

National Vote at Home Institute



he/him



Learn more about:

[Election Officials Center](#)

[Mail Ballot FAQs](#)

Mail Ballot Security

Michael Spitzer-Rubenstein

State Lead for Wisconsin (Leadership Now Fellow)

National Vote at Home Institute

([REDACTED])

he/him

[REDACTED]

Learn more about:

Election Officials Center

Mail Ballot FAQs

Mail Ballot Security

Deanna Debruler

From: Michael Spitzer-Rubenstein <michael@voteathome.org>
Sent: Monday, November 2, 2020 9:01 AM
To: Celestine Jeffreys
Cc: Diana Ellenbecker; Chris Pirlot; Steven Grenier
Subject: Re: Central Count Set Up Details (DPW)
Attachments: Log - Delivery Open and Close.docx

Hi all, here's the log I put together for moving ballots in the morning and evening.

It's meant to be printed double-sided so each truck will have its own sheet. We'll need to print 4 total, 2 for the morning, 2 for the evening.

Michael

On Fri, Oct 30, 2020 at 4:57 PM Celestine Jeffreys <Celestine.Jeffreys@greenbaywi.gov> wrote:

Celestine Jeffreys is inviting you to a scheduled Zoom meeting.

Join Zoom Meeting

Meeting ID: [REDACTED]

Passcode: [REDACTED]

One tap mobile

+19292056099,,82422490111#,,,,,0#,,763276# US (New York)

+13017158592,,82422490111#,,,,,0#,,763276# US (Germantown)

Dial by your location

+1 929 205 6099 US (New York)

+1 301 715 8592 US (Germantown)

+1 312 626 6799 US (Chicago)

+1 669 900 6833 US (San Jose)

+1 253 215 8782 US (Tacoma)

+1 346 248 7799 US (Houston)

Meeting ID: [REDACTED]

Passcode: [REDACTED]

Find your local number: <https://us02web.zoom.us/j/kmjPjfv6>

--

Michael Spitzer-Rubenstein
State Lead for Wisconsin (Leadership Now Fellow)
National Vote at Home Institute

Deanna Debruler

From: Diana Ellenbecker
Sent: Wednesday, October 21, 2020 8:20 AM
To: Kris Teske
Cc: Kim Wayte
Subject: RE: Assistance from NVAHI tomorrow

Kris / Kim,

Kris you are Clerk and this is your show!

I 100% agree that this person, can socially distance observe, but not in the Clerk's office. We can tactfully say until the lawsuit is done, we can't risk any more press. He could possibly help direct traffic or sit at the end of the hall to observe. Maybe even help sort in-coming ballots with the temp help.

Thank you,
Diana

From: Kris Teske
Sent: Tuesday, October 20, 2020 9:31 PM
To: Diana Ellenbecker <Diana.Ellenbecker@greenbaywi.gov>
Cc: Kim Wayte <Kim.Wayte@greenbaywi.gov>
Subject: RE: Assistance from NVAHI tomorrow

Really.....is Celestine running it now. Please let me know. The Clerk's Office said we didn't want anyone from the grant team (or contracted through the grant team) to be in our office. If he wants to give us suggestions (observing) we are fine with that but he shouldn't be working in the office. We need to social distance in the office I want the Clerk's staff to feel safe.

With the lawsuit I am not comfortable having him in the office. People are saying they are partisan group, we don't think it looks good.

████████████████████ tomorrow morning but Kim is aware of this.

I thought after the meeting today everything was good. I'm the Clerk and in charge of the ballots not the Mayor's Office.

I know you know all of this but this has got to stop. Celestine is still controlling the show and now Amaad is telling me what is right and what is wrong. If I am to step aside there needs to be a press release because I will NOT take the blame for anything they do.

Thanks for listening.

Kris Teske, WCMC
Green Bay City Clerk
100 N. Jefferson St., Rm 106
Green Bay, WI 54301
920-448-3014



From: Diana Ellenbecker
Sent: Tuesday, October 20, 2020 8:27 PM
To: Kris Teske <Kris.Teske@greenbaywi.gov>
Cc: Celestine Jeffreys <Celestine.Jeffreys@greenbaywi.gov>
Subject: FW: Assistance from NVAHI tomorrow

Fyi....

Thank you,
Diana

From: Celestine Jeffreys [<mailto:Celestine.Jeffreys@greenbaywi.gov>]
Sent: Tuesday, October 20, 2020 8:26 PM
To: Diana Ellenbecker <Diana.Ellenbecker@greenbaywi.gov>
Subject: RE: Assistance from NVAHI tomorrow

Hey, Diana!

Yes, he's there to help, but not to be an observer, per se. I will be here to introduce him to the staff and support him. He'll be here in the afternoon.

Thanks!!

Celestine Jeffreys
Chief of Staff, Mayor's Office
City of Green Bay

From: Diana Ellenbecker <Diana.Ellenbecker@greenbaywi.gov>
Sent: Tuesday, October 20, 2020 8:06 PM
To: Celestine Jeffreys <Celestine.Jeffreys@greenbaywi.gov>; Kris Teske <Kris.Teske@greenbaywi.gov>
Subject: Assistance from NVAHI tomorrow

Hi Celestine,

I have copied Clerk Teske on this e-mail. Please let us know where Michael will be located tomorrow afternoon, will he just be an observer? Since the Mayor's office is taking this appointment, will your department be meeting Michael at the door and introducing him to the Clerk's staff.

We are certainly open to hear some feedback from Michael on his observations after the close of business for potential changes on future days.

Is there an expectation of the Clerk's office staff to work with Michael tomorrow?

Thank you for the heads up that he will be in the office tomorrow.

Diana

From: Celestine Jeffreys [<mailto:Celestine.Jeffreys@greenbaywi.gov>]
Sent: Tuesday, October 20, 2020 7:38 PM
To: Diana Ellenbecker <Diana.Ellenbecker@greenbaywi.gov>
Subject: RE: Assistance

Hi, Diana!

EIPAV is early in-person absentee voting and the NVAHI is the national vote at home institute.

He will help crunch numbers and organize the voting downstairs. He offered to come, he's part of the Election grant, and I cleared it with the Mayor first.

Celestine Jeffreys
Chief of Staff, Mayor's Office
City of Green Bay

From: Diana Ellenbecker <Diana.Ellenbecker@greenbaywi.gov>
Sent: Tuesday, October 20, 2020 7:34 PM
To: Celestine Jeffreys <Celestine.Jeffreys@greenbaywi.gov>
Subject: RE: Assistance

Hi Celestine,
Can you explain more, what is EIPAV? What is NVAHI?

What would Michael be assisting us with?

Thank you,
Diana

From: Celestine Jeffreys [<mailto:Celestine.Jeffreys@greenbaywi.gov>]
Sent: Tuesday, October 20, 2020 7:27 PM
To: Diana Ellenbecker <Diana.Ellenbecker@greenbaywi.gov>
Subject: Assistance

Diana,

Tomorrow afternoon, Michael Spitzer-Rubenstein from the National Vote at Home Institute will visit us to provide some assistance on setting up the EIPAV. He has an MBA from NYU and is on loan to the NVAHI from Price Waterhouse Coopers.

Celestine Jeffreys
Chief of Staff, Mayor's Office
City of Green Bay

Deanna Debruler

From: Michael Spitzer-Rubenstein <michael@voteathome.org>
Sent: Friday, October 30, 2020 1:27 PM
To: Amaad Rivera; Jaime Fuge; Diana Ellenbecker; Kim Wayte; Celestine Jeffreys
Subject: Revised Central Count Roles
Attachments: Central Count Poll Worker Needs v2.xlsx

As discussed this morning:

65 people for shift 1 (6 AM - 3 PM)
65 people for shift 2 (2 PM - 11 PM)
25 people for shift 3 (10 PM - close)

I think the one big remaining question is just delivering the machines over to KI on Monday but I know, Diana, that you're working on it.

Michael

--

Michael Spitzer-Rubenstein
State Lead for Wisconsin (Leadership Now Fellow)
National Vote at Home Institute
(310) 980-2872
he/him



Learn more about:
[Election Officials Center](#)
[Mail Ballot FAQs](#)
[Mail Ballot Security](#)

Deanna Debruler

From: Kris Teske
Sent: Thursday, August 27, 2020 8:58 AM
To: Diana Ellenbecker
Subject: RE: BadgerBooks
Attachments: Re: FW: Following up on CTCL request; RE: Badger Books (Green Bay)

See attached and below in red. The first attached is from the grant team stating they would like the funds used for the 2020 elections (that's not what was said in the beginning). The second one is from the WEC (from June) stating we couldn't implement them until 2021 (this email was sent to the Ad Hoc Committee at that time).

Let me know if you have any questions.

Kris Teske, WCMC
Green Bay City Clerk
100 N. Jefferson St., Rm 106
Green Bay, WI 54301
920-448-3014



From: Diana Ellenbecker
Sent: Thursday, August 27, 2020 7:50 AM
To: Kris Teske <Kris.Teske@greenbaywi.gov>
Subject: RE: BadgerBooks

Hi Kris,
Thanks for sharing and I am sorry you are so frustrated. I completely understand why.

Ok, I am glad to hear you are on board with the BadgerBooks and I understand why you would not be able to implement for November. Do you think realistically we can order them this year so we can use the grant dollars? I saw the quotes, but what is the estimated cost for all the BadgerBooks we would need, just a quick number. Should we put in the requisition so we can move quickly if a decision is made? Yes, we can order them this year and would be delivered mid-December. The WEC isn't going to on the BadgerBooks until Dec. /Jan. I have an email into the WEC asking if we need 2 BadgerBooks (by law) to replace 2 poll books or 1 BadgerBook to replace 2 poll books. I will let you know the cost at that time. It will also depend on which one we choose. One style has more cords/plugins and the other doesn't but when the Badgerbook with the cords breaks it doesn't put the whole thing out of commission whereas the one with less cords means the whole unit goes back. My other concern is outlets at the polling locations. Some of the polling locations only have enough outlets for the tabulator and ExpressVote.

I agree with a dropbox in front of City Hall for curbside drop off. The back dropboxes are think are just temporary during COVID and will probably still be in use this November but going forward I would assume not. In my opinion to keep the one in back for absentee ballots is a mistake. I don't think City Staff will be able to get out of the parking lot the last two weeks before the election especially. Could also be more accidents where Celestine's car is parked (that used to be an issue). We get a lot of complaints that it is hard to find. We will be putting information in the absentee envelopes stating where the drop boxes will be located.

Why do you think the fire station are a huge mistake, location? We had a polling location at the polls and people just park and do whatever they want. These locations will probably be okay for elections other than the Presidential but I think people will block the driveways (again probably the week before the election) and cause some delays.

I really think the action of "receive on file" was the wrong action, they should have referred back to staff right away. You were already going to follow-up on several of the items, so it was already going to be discussed again.

100% you should never feel pressured to do something that is against the law!!

Thank you,
Diana

From: Kris Teske
Sent: Wednesday, August 26, 2020 10:26 AM
To: Diana Ellenbecker <Diana.Ellenbecker@greenbaywi.gov>
Subject: RE: BadgerBooks

First, I don't think we have a choice. The Mayor and Celestine are the ones who suggested these for this year. I wanted to wait until the "bugs" were worked out but this is probably our only time to be able to afford them. In the long run this should help alleviate overtime after the Presidential Election every 4 years. After telling my concerns at the Ad Hoc Committee (before the grant) everyone understood why I didn't want them. Once we had the grant I emailed the WEC and was told we wouldn't get them until next year (email was sent to Celestine and I believe put in the Ad Hoc packet). I had stated then there is no way I would start using BadgerBooks for the November election anyway and everyone understood. Now Celestine is surprised that I don't want to use them for November but is going along with it (I think). But to answer your question yes I would like them but not for November.

My concern is all these additional things the "group" wants to add will affect the budget in the following years. Who is going to do all of this setting up (I think it should be an IT person not the setup crew-31 polling locations)? Are we going to leave this equipment overnight at the polls setup? I don't think with everything else this could be done from 6:30 a.m. to 7 a.m. on Election Day.

Also, Celestine and I talked on Monday about dropboxes and I told her my thoughts. She was going to have other people make the decision where these will be placed. I said I am the Clerk. She said where do you want them and I told her. She stated the "mentors" think they should be on the City's property which I understand but I said that is our issue to begin with concerning polling locations. She said pick 8 places and then we can discuss with the group?!?!? Not 5 minutes later she sends an email to Chief Litton asking if we can have 4 of the 5 at the Fire Stations. Evidently, the Chief told her this is okay. So that is where they are going to go IF we can find some to buy in time. When Council approved 2 dropboxes and I knew the "group" wanted more. I said to Celestine if we are going to buy more we might get a better deal (I wasn't allowed to purchase anything without her approval) than buying the two now. I think the Fire Stations are a huge mistake. I also suggested we put a dropbox in front of City Hall to drop their ballots in from their car. She said we will do that but also keep the one in the back. Why are we keeping the one in the back?!?!? This will be a disaster for November.

One other thing, Ald. Dorff and I talked yesterday. She doesn't want my responses to the second "report" to go to Ad Hoc. I said why is it okay to throw me under the bus but when it's the other way around it's a different story. I told her I wanted them on the agenda and she kept saying are you sure, are you sure. Finally, I said I don't care and right away she said okay I'll call Celestine. So she got what she wanted but I let her know I knew what was going on the whole time. Even Kim said to me the Wednesday after the Council meeting that Ald. Dorff had Ald. Galvin pull this and refer back. Do they think we are stupid and can't see what they are doing???? She said it was all a misunderstanding. I told her my concerns:

- 1) Ald. Galvin stated at Council he read the report and watched the video. I told her there wasn't a report, minutes, or a video to watch of the Ad Hoc meeting before the Council meeting. So I didn't understand why that was said. She later admitted Ald. Galvin asked for her report. So he didn't know that I had talked about each point and that some of the things would be looked into. Celestine put received and placed on file so they thought nothing was being done.
- 2) I also asked who told her to go to the polling locations and report back, she said Celestine and Susan (this wasn't discussed at the Ad Hoc meeting). I have nothing to hide. She admitted there is the "group" that are discussing and making decisions. So for show I might be asked my opinion but as you can see above things have already been decided by the "group".

If I knew they would get the blame for the decisions I wouldn't say anything but just like in April when I didn't make the final decisions (even though I gave my opinion-I have the email) I will be the one to get blamed because it's the Clerk's job.

On Saturday I saw on the City's facebook page the City was supporting COVO's registration drive. No one ever told the Clerk's Office. Instead of people making appointments in the Clerk's Office we could have been giving them this option but Celestine didn't feel it was important to let us know, the ones that are taking the phone calls. Matt from DPW talked to St. Norbert College about college students helping at the polls when I was working with someone already. She has excluded me from that whole portion of the planning....it's so embarrassing!

There is one more thing I want to say: If I am ever asked to do anything against the law the answer will be NO! If you want more clarification on this please give me a call.

Thanks for listening.

Kris Teske, WCMC
Green Bay City Clerk
100 N. Jefferson St., Rm 106
Green Bay, WI 54301
920-448-3014



From: Diana Ellenbecker
Sent: Wednesday, August 26, 2020 9:26 AM
To: Kris Teske <Kris.Teske@greenbaywi.gov>
Subject: RE: BadgerBooks

Kris,
Are BadgerBooks something you and Kim want?

Thank you,
Diana

From: Kris Teske
Sent: Monday, August 24, 2020 8:15 AM
To: 'Susan Smith' <sksmith@smithlegaladvisors.com>; Celestine Jeffreys <Celestine.Jeffreys@greenbaywi.gov>
Cc: Kim Wayte <Kim.Wayte@greenbaywi.gov>; Diana Ellenbecker <Diana.Ellenbecker@greenbaywi.gov>
Subject: BadgerBooks

Good Morning,

Here are the quotes for the BadgerBooks.

Some things to consider:

Who will set all of this equipment up for Election Day?

Who will take all of this equipment down after the Election?

Are there enough outlets in the rooms we are using for us to add additional equipment?

Thanks,

Kris Teske, WCMC
Green Bay City Clerk
100 N. Jefferson St., Rm 106
Green Bay, WI 54301
920-448-3014



Hotel	Topic/Topic	Change Log Entries	Prices	Format	Event Date Range
GRBRC	ALL	3 days	Show	Without Changes	
Function Room			Event Order Type		
ALL			ALL		

Event Date: Sunday, November 1, 2020

Date	Start Time	End Time	Location	Attendance	Bkng:	On Site:
Sun, Nov 1	08:00 AM	04:00 PM	GRAND BALLROOM	E/G/S 100/0/0	2021 Central Count Event: SETUP EO: Setup EO #: 14982306	Diana Ellenbecker EPM: Tracy Hillesheim SM: Tracy Hillesheim Bill Inst:
Reader Board Ind						
Primary PM# 9639 PM#:						

	Serve Time	Servings	Description	Price
Setup	08:00 AM		See Diagram provided by EPM ROOM MUST BE SET AND READY BY 8AM FOR CLIENT SETUP 8x30 Table(s) (50) 8x30 tables set per diagram - 4 Groupings of 7 tables; additional tables per diagram Black Mesh Chairs (100) chairs set per diagram 32x8x24 Riser with Steps per diagram Recycle Bin and Garbage Can *Place several garbage cans and recycle bins around the perimeter of the room	35.00 Ea.
AV	08:00 AM	10	Power Drop	
Security	08:00 AM		SECURITY NOTE Between 8AM and noon, workers will arrive with counting machines that will need to go to Grand Reg Counter. Workers will go thru security and get temp checked and wrist banded and will need to use some carts to move machines upstairs. Engineering is re-keying the Grand Reg Counter and providing group with 4 keys and Kristine Hall. GM will hold the 5th key in case of emergency. ... After Event Setup has sprayed room. Grand Ballroom will need to be locked.	
Engineering	08:00 AM		Meeting Room Lock Change(s) Number of keys to provide: 5 (4 to group and 1 for hotel to keep-Kristine Hall will hold for hotel) Deliver keys to: Michael Spitzer-Rubenstein Restore meeting room locks on: Friday, 11/6/2020.	275.00 Ea.
Misc. All	08:00 AM		EPM NOTE Michael Spitzer-Rubenstein will be the on-site contact for the group. Tracy Hillesheim has his cell number should anyone have questions or needs to contact Michael.	

Hotel	Topic	Change Log Entries	Prices	Format	Event Date Range
GRBRG	ALL	3 days	Show	Without Changes	
Function Room			Event Order Type		
ALL			ALL		

Event Date: Tuesday, November 3, 2020

Date	Start Time	End Time	Location	Attendance	Bkng:	Event:	EO:	EO #:	On Site:
Tue, Nov 3	05:00 AM	02:00 AM	GRAND BALLROOM	E/G/S 100/0/0	2021 Central Count	Central Count	Meeting	14982308	Diana Ellenbacher
									EPM: Tracy Hillesheim
									SM: Tracy Hillesheim
									Bill Inst.
Reader Board Ind X									
Primary PM# 9639 PM#:									

	Serve Time	Servings	Description	Price
Setup	05:00 AM		Existing Set	10,000.00 Ea.
Venue Rental	05:00 AM	1	Room Rental, Tax, No Service Charge	
Security	05:00 AM		<p>SECURITY NOTE Please have the outside doors to the staircase by Riverview 3 unlocked as poll workers will be parking in the WPS lot and entering thru the staircase by Riverview 3 Room.</p> <p>...</p> <p>DO NOT UNLOCK GRAND BALLROOM UNTIL MICHAEL SPITZER-RUBENSTEIN REQUESTS AND IS WITH SECURITY WHEN UNLOCKING THE GRAND BALLROOM DOORS.</p> <p>...</p> <p>Sometime around 6:15AM, ballots will begin to arrive at hotel. There will be approx 47 boxes of ballots that will go to Grand Ballroom. The person/s bringing the ballots will go to security for tem check and wrist banding and will need assistance getting a red cart/s and shown the way to Grand Ballroom via elevator and back of house.</p> <p>...</p>	
Engineering	05:00 AM		<p>Meeting Room Lock Change(s) Number of keys to provide Delivar keys to: Restore meeting room locks on</p>	
Misc. All	05:00 AM		<p>EPM NOTE On Tuesday, hotel should expect to see at least 4 media channels arriving who will be doing story or video taping in the Grand Ballroom. Amaad Rivera is the main contact for media on Tuesday. Please see Tracy Hillesheim should you need a phone number to reach Mr. Rivera.</p>	

Hotel	Topic	Change Log Entries	Prices	Format	Event Date Range
GRBRG	ALL	3 days	Show	Without Changes	
Function Room			Event Order Type		
ALL			ALL		

Event Date: Sunday, November 1, 2020

Date	Start Time	End Time	Location	Attendance	Bkng: 2021 Central Count	On Site: Diana Ellenbecker
Sun, Nov 1	08:00 AM	04:00 PM	GRAND BALLROOM	E/G/S	Event: SETUP	EPM: Tracy Hillesheim
Reader Board Ind	-			100/0/0	EO: Setup	SM: Tracy Hillesheim
Primary PM# 9639		PM#:			EO #: 14982306	Bill Inst:

	<u>Serve Time</u>	<u>Servings</u>	<u>Description</u>	<u>Price</u>
Setup	08:00 AM		See Diagram provided by EPM ROOM MUST BE SET AND READY BY 8AM FOR CLIENT SETUP 8x30 Table(s) (50) 8x30 tables set per diagram - 4 Groupings of 7 tables; additional tables per diagram Black Mesh Chairs (100) chairs set per diagram 32x8x24 Riser with Steps per diagram Recycle Bin and Garbage Can *Place several garbage cans and recycle bins around the perimeter of the room	35.00 Ea.
AV	08:00 AM	10	Power Drop	
Security	08:00 AM		SECURITY NOTE Between 8AM and noon, workers will arrive with counting machines that will need to go to Grand Reg Counter. Workers will go thru security and get temp checked and wrist banded and will need to use some carts to move machines upstairs. Engineering is re-keying the Grand Reg Counter and providing group with 4 keys and Kristine Hall, GM will hold the 5th key in case of emergency. *** After Event Setup has sprayed room, Grand Ballroom will need to be locked.	
Engineering	08:00 AM		Meeting Room Lock Change(s) Number of keys to provide: 5 (4 to group and 1 for hotel to keep-Kristine Hall will hold for hotel) Deliver keys to: Michael Spitzer-Rubenstein Restore meeting room locks on: Friday, 11/6/2020.	275.00 Ea.
Misc. All	08:00 AM		EPM NOTE Michael Spitzer-Rubenstein will be the on-site contact for the group. Tracy Hillesheim has his cell number should anyone have questions or needs to contact Michael.	

Hotel	Topic	Change Log Entries	Prices	Format	Event Date Range
GRBRG	ALL	3 days	Show	Without Changes	
Function Room			Event Order Type		
ALL			ALL		

Event Date: Monday, November 2, 2020

Date	Start Time	End Time	Location	Attendance	Bkng: 2021 Central Count	On Site: Diana Ellenbecker
Mon, Nov 2	07:00 AM	09:00 PM	GRAND BALLROOM	E/G/S 100/0/0	Event: SETUP EO: Setup EO #: 14982307	EPM: Tracy Hillesheim SM: Tracy Hillesheim Bill Inst:
Reader Board Ind	X					
Primary PM#	9639	PM#:				

	<u>Serve Time</u>	<u>Servings</u>	<u>Description</u>	<u>Price</u>
Setup	07:00 AM		Refresh Existing Set *Group requests we static spray the room after 7PM to ensure room is santized and ready for poll workers arrival on Tuesday morning at 5:30AM	
Security	07:00 AM		SECURITY NOTE Unlock Grand Ballroom at 7AM and lock again at 9PM	

Hotel	Topic	Change Log Entries	Prices	Format	Event Date Range
GRBRG	ALL	3 days	Show	Without Changes	
Function Room			Event Order Type		
ALL			ALL		

Event Date: Tuesday, November 3, 2020

Date	Start Time	End Time	Location	Attendance	Bkng:	On Site:
Tue, Nov 3	05:00 AM	02:00 AM	GRAND BALLROOM	E/G/S 100/0/0	2021 Central Count Event: Central Count EO: Meeting EO #: 14982308	Diana Ellenbecker EPM: Tracy Hillesheim SM: Tracy Hillesheim Bill Inst:
Reader Board Ind	X					
Primary PM#	9639	PM#:				

	Serve Time	Servings	Description	Price
Setup	05:00 AM		Existing Set	
Venue Rental	05:00 AM	1	Room Rental, Tax, No Service Charge	10,000.00 Ea.
Security	05:00 AM		SECURITY NOTE Please have the outside doors to the staircase by Riverview 3 unlocked as poll workers will be parking in the WPS lot and entering thru the staircase by Riverview 3 Room. *** DO NOT UNLOCK GRAND BALLROOM UNTIL MICHAEL SPITZER-RUBENSTEIN REQUESTS AND IS WITH SECURITY WHEN UNLOCKING THE GRAND BALLROOM DOORS. *** Sometime around 6:15AM, ballots will begin to arrive at hotel. There will be approx 47 boxes of ballots that will go to Grand Ballroom. The person/s bringing the ballots will go to security for tem check and wrist banding and will need assistance getting a red cart/s and shown the way to Grand Ballroom via elevator and back of house. ***	
Engineering	05:00 AM		Meeting Room Lock Change(s) Number of keys to provide: Deliver keys to: Restore meeting room locks on:	
Misc. All	05:00 AM		EPM NOTE On Tuesday, hotel should expect to see at least 4 media channels arriving who will be doing story or video taping in the Grand Ballroom. Amaad Rivera is the main contact for media on Tuesday. Please see Tracy Hillesheim should you need a phone number to reach Mr. Rivera.	

Deanna Debruler

From: Michael Spitzer-Rubenstein <michael@voteathome.org>
Sent: Friday, October 30, 2020 4:36 PM
To: Celestine Jeffreys; Mike Hronek; Amaad Rivera; Jaime Fuge; Shelby Edlebeck
Subject: Wifi for KI
Attachments: City-of-Green-Bay 11.03.2020.pdf

----- Forwarded message -----

From: Trent Jameson <trent.jameson@psav.com>
Date: Tue, Oct 27, 2020 at 5:11 PM
Subject: Nov 3rd event...
To: michael@voteathome.org <michael@voteathome.org>
Cc: Hillesheim, Tracy (GRBRG) <tracy.hillesheim@hyatt.com>

Hi Michael,

Here is the quote for the event on Tuesday, Nov 3rd at the Hyatt Regency and KI Convention Center. You decided that you didn't need the projector or screen so I added the 10 power drops around the room and I'll comp the internet for the event. We'll set up the power drops in the room on Sunday after the hotel has the tables in place. I'm only going to charge you for one day and the other days will be comp'd.

I'll have my team create two separate SSID's for you.

One SSID will be hidden and it's: 2020vote There will be no password or splash page for this one and it should only be used for the sensitive machines that need to be connected to the internet.

The other SSID will be: gbvote and that one can be seen in the settings app of your phone or laptop under "networks" and should be used for the poll workers who need internet.

The third SSID will be: Hyatt_Meeting and that one can also be seen in the settings app of your phone or laptop under "networks" and that will have a password of Hyatt123 and should be given out to media or other guests not part of your team.

If you need anything else please reach out to me and we'll do everything we can to make this event smooth and hiccup free.

Trent Jameson
Director, Event Technology - PSAV®
Hyatt Regency and KI Convention Center

333 Main Street, Green Bay, WI 54301

■ office: 920.321.5083 ■ mobile [REDACTED]

[PSAV Virtual Events - Click Here](#)

--

Michael Spitzer-Rubenstein

State Lead for Wisconsin (Leadership Now Fellow)

National Vote at Home Institute

(310) 980-2872

he/him



Learn more about:

[Election Officials Center](#)

[Mail Ballot FAQs](#)

[Mail Ballot Security](#)

Deanna Debruler

From: Michael Spitzer-Rubenstein <michael@voteathome.org>
Sent: Sunday, November 1, 2020 10:46 AM
To: Shelby Edlebeck
Cc: Celestine Jeffreys; Mike Hronek; Amaad Rivera; Jaime Fuge
Subject: Re: Wifi for KI

Got the passwords, too! (And I can report that both networks reach my hotel room on the 8th floor, so I assume they just set these across the entire system).

Network Name: [REDACTED]

(THIS IS AN OPEN NETWORK / NO PASSWORD WITH A HIDDEN SSID)

and

Network Name: [REDACTED]

Password: [REDACTED]

On Fri, Oct 30, 2020 at 4:42 PM Shelby Edlebeck <Shelby.Edlebeck@greenbaywi.gov> wrote:

Awesome, thanks for the info! See you Monday at 10am

Thank you,

Shelby Edlebeck

920.448.3207

From: Michael Spitzer-Rubenstein [mailto:michael@voteathome.org]
Sent: Friday, October 30, 2020 4:36 PM
To: Celestine Jeffreys <Celestine.Jeffreys@greenbaywi.gov>; Mike Hronek <mike.hronek@greenbaywi.gov>; Amaad Rivera <Amaad.Rivera@greenbaywi.gov>; Jaime Fuge <Jaime.Fuge@greenbaywi.gov>; Shelby Edlebeck <Shelby.Edlebeck@greenbaywi.gov>
Subject: Wifi for KI

----- Forwarded message -----

From: **Trent Jameson** <trent.jameson@psav.com>

Date: Tue, Oct 27, 2020 at 5:11 PM

Subject: Nov 3rd event...

To: michael@voteathome.org <michael@voteathome.org>

Cc: Hillesheim, Tracy (GRBRG) <tracy.hillesheim@hyatt.com>

Hi Michael,

Here is the quote for the event on Tuesday, Nov 3rd at the Hyatt Regency and KI Convention Center. You decided that you didn't need the projector or screen so I added the 10 power drops around the room and I'll comp the internet for the event. We'll set up the power drops in the room on Sunday after the hotel has the tables in place. I'm only going to charge you for one day and the other days will be comp'd.

I'll have my team create two separate SSID's for you.

One SSID will be hidden and it's: [REDACTED] There will be no password or splash page for this one and it should only be used for the sensitive machines that need to be connected to the internet.

The other SSID will be: [REDACTED] and that one can be seen in the settings app of your phone or laptop under "networks" and should be used for the poll workers who need internet.

The third SSID will be: [REDACTED] and that one can also be seen in the settings app of your phone or laptop under "networks" and that will have a password of [REDACTED] and should be given out to media or other guests not part of your team.

If you need anything else please reach out to me and we'll do everything we can to make this event smooth and hiccup free.

Trent Jameson
Director, Event Technology - PSAV®
Hyatt Regency and KI Convention Center
333 Main Street, Green Bay, WI 54301
■ office: 920.321.5083 ■ mobile: 920.636.0383

[PSAV Virtual Events - Click Here](#)

--

Michael Spitzer-Rubenstein

State Lead for Wisconsin (Leadership Now Fellow)

National Vote at Home Institute



he/him



Learn more about:

[Election Officials Center](#)

[Mail Ballot FAQs](#)

[Mail Ballot Security](#)

--

Michael Spitzer-Rubenstein

State Lead for Wisconsin (Leadership Now Fellow)

National Vote at Home Institute



he/him



Learn more about:

[Election Officials Center](#)

[Mail Ballot FAQs](#)

[Mail Ballot Security](#)

Deanna Debruler

From: Michael Spitzer-Rubenstein <michael@voteathome.org>
Sent: Sunday, November 1, 2020 10:52 AM
To: Diana Ellenbecker; Jaime Fuge; Amaad Rivera
Subject: Central Count Staffing Roles
Attachments: KI Diagram with Roles.pdf; Central Count Staff List.xlsx

Hi all,

In advance of meeting tomorrow, I'm attaching two files:

1. A diagram of KI with tables marked.
2. A Central Count Staff List (blank but with all the roles we'll need for shifts 1 and 2). For roles with a partner, I labeled them A and B.

I'm not sure what the count is right now, but here's where I would put extra people:

- 1 extra person for each of the scanners (so 3 total), working on paperwork and ballot flattening
- Extra runners/ballot sorters (depending on how many ballots we get on Election Day, either very busy or very boring), could also trade-off with the person guarding the dropbox
- An extra Reconstruction table (would need to be experienced)
- Check-in table for press/observers and second shift

Michael

--

Michael Spitzer-Rubenstein
State Lead for Wisconsin (Leadership Now Fellow)
National Vote at Home Institute
(310) 980-2872
he/him



Learn more about:
[Election Officials Center](#)
[Mail Ballot FAQs](#)
[Mail Ballot Security](#)

Deanna Debruler

From: Michael Spitzer-Rubenstein <michael@voteathome.org>
Sent: Friday, October 30, 2020 5:28 PM
To: Jaime Fuge; Kim Wayte
Subject: Milwaukee Central Count Manual
Attachments: Central Count Procedures (Final).pdf

Here's what we helped Milwaukee create. Slightly different steps and I want to use photos of Green Bay forms (since Milwaukee created different forms) but this is the basic idea of what we'd do.

Michael

--

Michael Spitzer-Rubenstein
State Lead for Wisconsin (Leadership Now Fellow)
National Vote at Home Institute
(310) 980-2872
he/him



Learn more about:

[Election Officials Center](#)

[Mail Ballot FAQs](#)

[Mail Ballot Security](#)

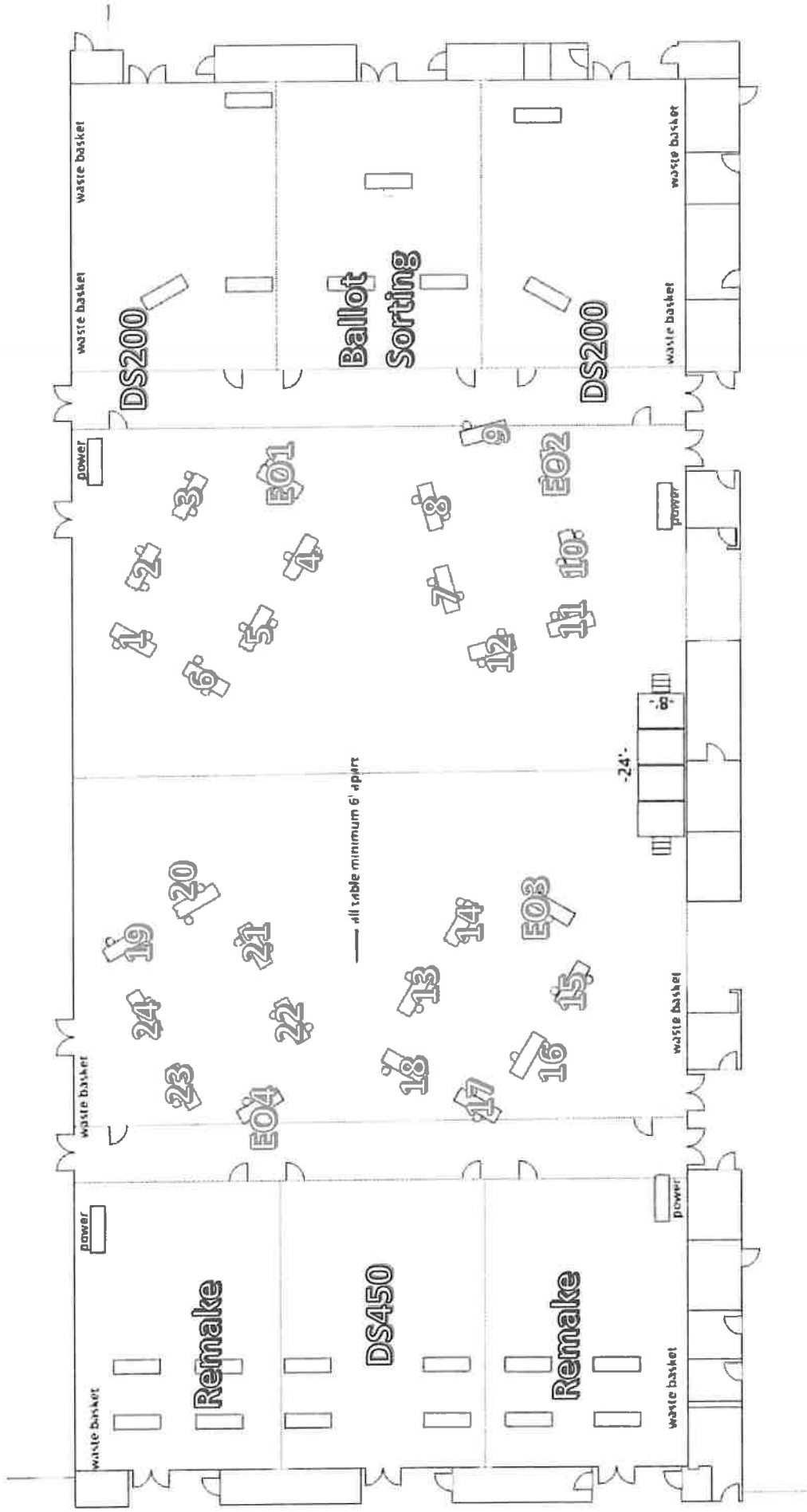

Deanna Debruler

From: Michael Spitzer-Rubenstein <michael@voteathome.org>
Sent: Wednesday, October 28, 2020 12:55 PM
To: Diana Ellenbecker
Cc: Amaad Rivera
Subject: Re: KICC Central count layout
Attachments: Ki Diagram v2.pdf

Hi Diana, was just about to email you!

I'm attaching the diagram we have now. We'll still need to make changes, depending on how many DS200s we get but we'll have 50 tables and 100 chairs, which should be more than enough.

Two questions for you:

1. Did you get an answer about when ES&S will move the 450 over there?
2. Is Kyle (he's the ES&S guy, right?) going to get us DS200s back from the county? Do you know how many he's asking for?

Thanks!
Michael

On Wed, Oct 28, 2020 at 12:50 PM Diana Ellenbecker <Diana.Ellenbecker@greenbaywi.gov> wrote:

Hi Amaad/Michael, do you have a new layout for central count at KICC? If not, who can I talk to about this?

After learning on how the DS450 works we are going to need a table on each side of the machine. We will also need an area for 47 bins to store counted ballots throughout the day.

Nearby we will also need room for the two DS200 with a table.

Not to mention the 24 or so table for processing the ballots and a table to reconstructs which needs to be near the DS450.

Just a few things I was thinking about.

Entrance with A-Frame Sign



Entrance with A-Frame Sign



FIRST FLOOR PLAN
SCALE: 3/32" = 1'-0"

Exit with A-Frame Sign

Voter Check-In Stations.
Voter checks in, receives ballot packet and then is instructed to vote at booths in the hallway and to sign their ballot with the clerk at the manned ballot box.

-  Manned Ballot Drop off w/ Clerk
-  Voting Booth
-  Stanchion(s)

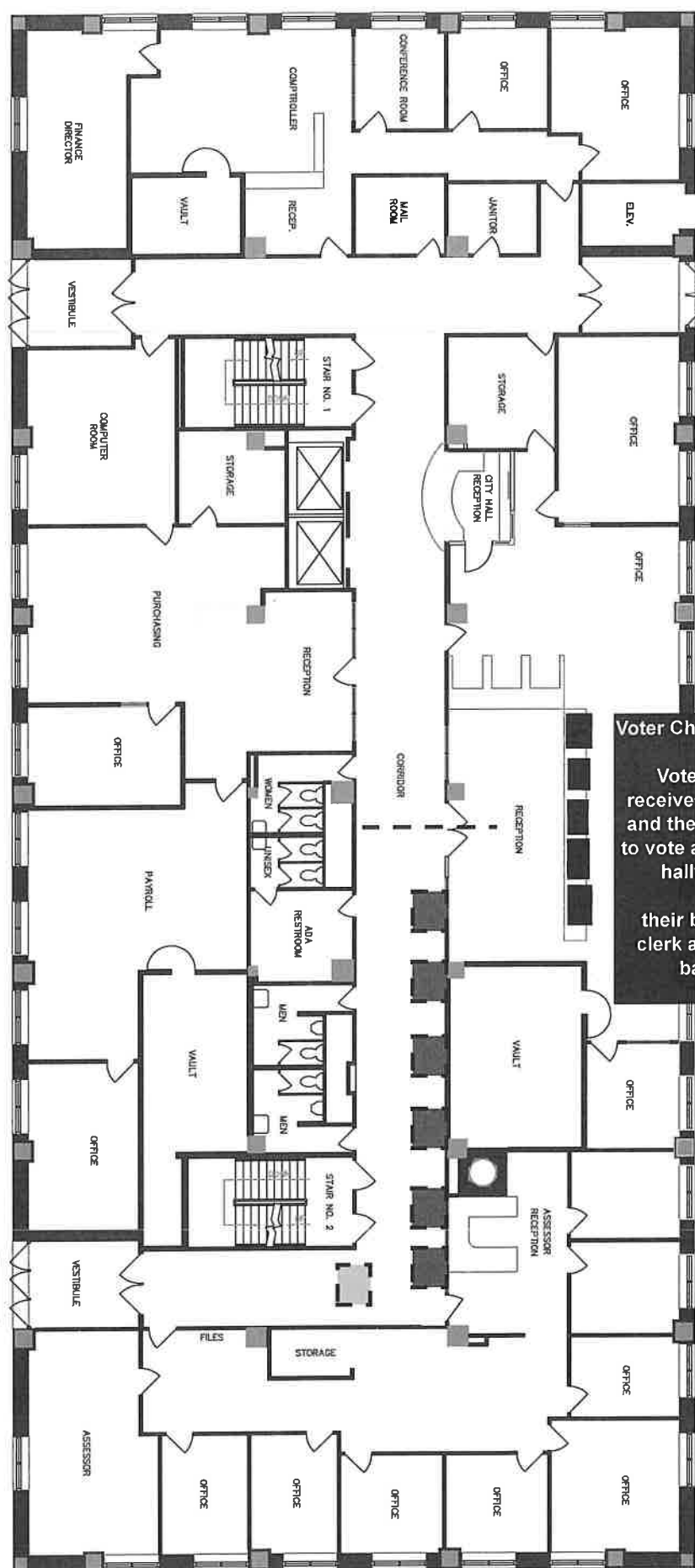

Day	Time	Task	People Needed	Notes
Monday	PM	Prep ballot bins	Kim and staff	1 DS450, 2 DS200s, 4 envelope opening machines
	TBD	Move machines to KI	DPW or Maintenance	PPE, badges/stickers, printer, portable dropbox, list of assignments, table signs, pens, training materials, letter openers
	TBD	Move supplies to KI KI Setup	Amaad and Michael	2
Tuesday	6am	Move ballot bins to KI	DPW	Michael at KI to guide
Shift 1 6am-3pm		Ballot sorting		1 Ideally should be WisVote-trained
		Envelope Opening Machine Operators		4 Also floater within pod for breaks 48 24 teams
		Ballot preparation teams		2 Diana?
		Ballot scanners (DS-450)		2 1 for each machine
		Ballot scanners (DS-200)		2
		Runners and Ballot Flatteners		4 2 teams, should be experienced
		Ballot reconstruction		2 Jaime, Amaad, (also MSR)
		Supervision and check-in		65
		Shift 1 total		
		Shift 2 total		
Shift 2 2pm-11pm		Ballot sorting		1 Ideally should be WisVote-trained
		Envelope Opening Machine Operators		4 Also floater within pod for breaks 48 24 teams
		Ballot preparation teams		2
		Ballot scanners (DS-450)		2 1 for each machine
		Ballot scanners (DS-200)		2
		Runners and Ballot Flatteners		4 2 teams, should be experienced
		Ballot reconstruction		2 Jaime, Amaad, (also MSR)
		Supervision and check-in		65
		Shift 2 total		
		Shift 3 total		
Shift 3 10pm-close		Ballot sorting		1
		Ballot preparation teams		12 6 teams
		Ballot scanners (DS-450)		2

Ballot scanners (DS-200)	2	1 for each machine
Runners and Ballot Flatteners	2	
Ballot reconstruction	4	2 teams, should be experienced
Supervision and check-in	2	Jaime, Amaad, (also MSR)
Shift 3 total	25	

Close	Move ballots to City Hall	DPW
	Take memory sticks to City Hall	Jaime

Central Count Absentee Ballot Processing Procedures

Table of Contents

Important Information.....	1	ExpressVote Ballots.....	6
Contents of Goldenrod Envelope.....	2	Emailed Ballots.....	6
Types of Ballots.....	2	Rejected Envelopes.....	7
Pre-Processing Procedures.....	3	Reconstructing A Ballot.....	8
Processing Official Ballots.....	5	Completed Work.....	11

Important Information

- ▶ You will be working in pairs safely distanced from each other
- ▶ We are taking as many safety precautions as possible, everyone will be issued mask(s) and gloves



- ▶ Absentee ballot processing will begin at **7:00 AM** when the manager announces:
“The polls are now open”
- ▶ All absentee ballot envelopes prior to being processed on Election Day have already been scanned, sorted into ward order, and alphabetized by last name
- ▶ Each team will receive **one** Ward Packet at a time

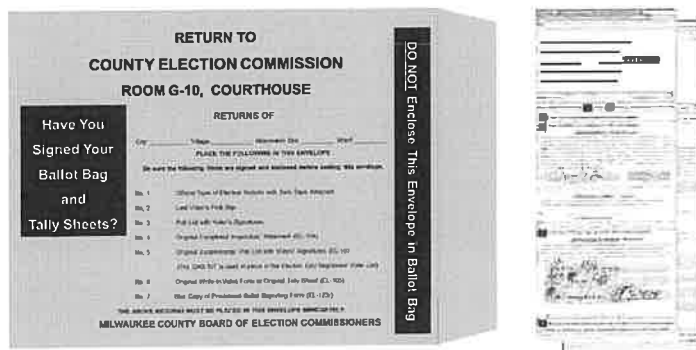

Contents of Goldenrod Envelope

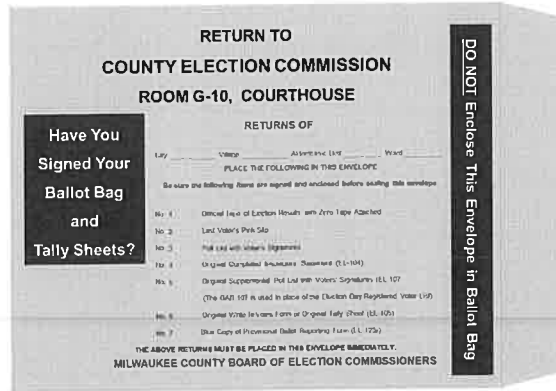

Used By Absentee Ballot Opening Team:

Used By Ballot Tabulating Team:
Ballot Bag

Ward Sign

Ward 1

Absentee Ballot Log

(GAB-104)

Voter Number Sheet

Registered Write-ins

Types of Ballot You Will Be Processing

▶ Official Ballots

- 90% of your ballots
- So long as the ballot is the correct ward and not damaged, nothing needs to be done other than assigning a voter number



▶ ExpressVote Ballots

- Assign voter number on bottom of ballot and keep a separate stack for each ward
- These **do not need to be reconstructed** unless there is damage

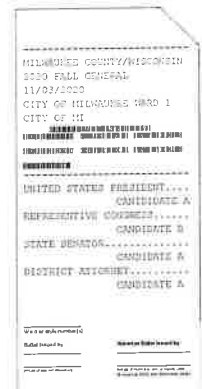

▶ Emailed

- All emailed ballots need to be reconstructed
- Keep the certificate and empty envelope with your absentee envelopes



▶ Federal Only Ballots

- All Federal only ballots need to be reconstructed
- Only reconstruct the offices that are on the original ballot
- ALL other races are left blank

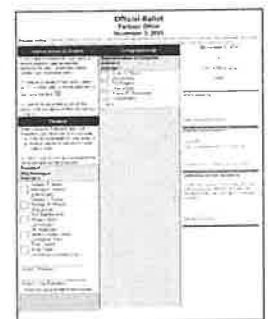

Pre-Processing Procedures

1 Remove all record keeping paperwork for the Goldenrod Envelope

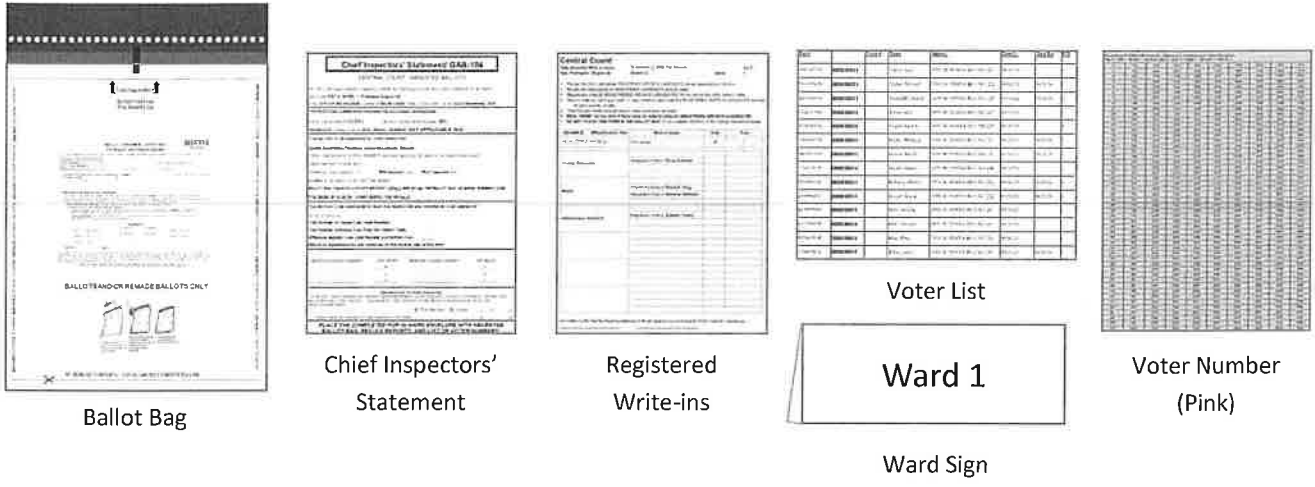

2 Confirm on the Chief Inspectors' Statement (GAB-104) that the serial number on the Ballot Bag matches the serial number on the GAB-104

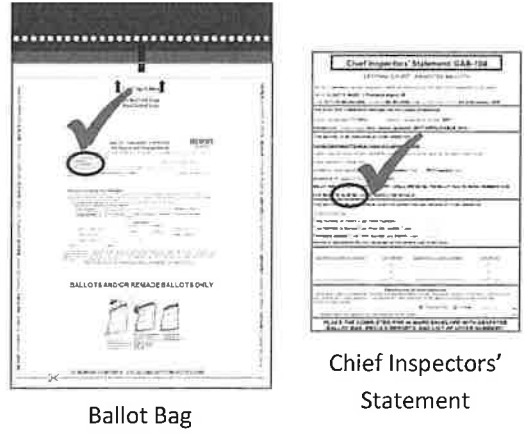

3 Circle and initial that the serial numbers match on the GAB-104

NUMBER OF BALLOTS FOR THIS WARD:
 BALLOT BAG CHAIN-OF-CUSTODY RECORD - CIRCLE AND INITIAL THE BALLOT BAG TIE SERIAL NUMBERS USED FOR WARD #1 IS 58190 - CHIEF INSPECTOR INITIALS: CWV

4 You and your partner will sign that you are working on this ward

<u>Signatures of Election Inspectors</u>	<u>Time Worked</u>	<u>Signatures of Election Inspectors</u>	<u>Time Worked</u>
<u><i>Christina Wade-Veg</i></u>	_____ to _____	_____	_____ to _____
<u><i>Justine Zuij</i></u>	_____ to _____	_____	_____ to _____
_____	_____ to _____	_____	_____ to _____

Pre-Processing Procedures

5 Place the ward sign on the edge of the table, so that it is visible to observers

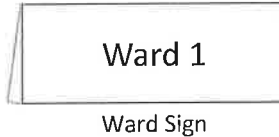

6 Split your ward's envelopes in half with your partner
**Keep them in alphabetical order*



7 Review the envelopes for:
▶ Voter signature
▶ Witness signature
▶ Witness address
(house number, street name, city)
**if written in red: accept*

! IF ANY ENVELOPES ARE MARKED AS "REJECTED" SEE PAGE 7

2 Sign and date your envelope as the voter (below).

CERTIFICATION OF VOTER (Required!)

I certify, subject to the penalties for false statements of Wis. Stat. § 12.60(1)(b), that I am a resident of the ward of the municipality in the county of the state of Wisconsin indicated hereon, and am entitled to vote in the ward at the election indicated hereon; that I am not voting at any other location in this election; that I am unable or unwilling to appear at the polling place in the ward on election day, or I have changed my residence within the state from one ward to another later than 28 days before the election. I certify that I exhibited the enclosed ballot, unmarked, to the witness, that I then in the presence of the witness and in the presence of no other person marked the ballot and enclosed and sealed the ballot in this envelope in a manner that no one but myself and any person providing assistance understands. Wis. Stat. § 6.87(5). If I requested assistance, could know how I voted. I further certify that I requested this ballot.

X Jane Voter 10 25 20
 ▲ Signature of Voter ▲ Today's Date

(All voters must sign. If a voter is unable to sign, an assistant may sign the voter's name for them. The assistant must also sign their own name under the Certification of Assistant.)

CERTIFICATION OF ASSISTANT (if applicable)

I certify that the voter named on this certificate is unable to sign his/her name or make his/her mark due to a physical disability, and that I signed the voter's name at the direction and request of the voter.

X _____
 ▲ Signature of Assistant ▲

Note: Assistants must sign the voter's name for them in Step 2, in addition to the assistant signature on the line above. A witness signature in Step 3 is also required. The assistant may also be the witness.

3 Have your witness sign and write their address (below).

CERTIFICATION OF WITNESS (Required!)

I, the undersigned witness, subject to the penalties for false statements of Wis. Stat. § 12.60(1)(b), certify that I am an adult U.S. Citizen and that the above statements are true and the voting procedure was executed as stated. I am not a candidate for any office on the enclosed ballot (except in the case of an incumbent municipal clerk). I did not solicit or advise the voter to vote for or against any candidate or measure. I further certify that the name and address of the voter is correct as shown.

1. John Witness
 ▲ Signature of ONE Witness - An adult, U.S. citizen ▲

123 Main St
 ▲ Address of Witness - Street address or box number (REQUIRED) ▲

Madison WI 53202
 ▲ Address of Witness - City, state, and zip code (REQUIRED) ▲

2. _____
 ▲ (If witnesses are Special Voting Deputies, both must sign) ▲

Voter Signature

Witness Signature

Witness Address

8 After reviewing all the of the envelopes and removing any to be rejected, team members should take the envelopes to an envelope opening station in the room



Return to your table, when the envelopes have been opened

Processing Official Ballots

- 1 Partner 1
 - A. Announce the voter's name
 - B. Number the envelope
 - C. Remove the ballot from the envelope
 - D. Number the ballot

Jane Voter

A

B

C

D

- 2 Partner 2
 - A. Announce the voter number
 - B. Cross the number off the voter number sheet
 - C. Record the number on the Absentee Voter Log

1

A

November 3, 2020 Fall General –Milwaukee Central Count Voter Numbers
 Site Name: Firehouse—Engine 38 District: 9 Ward 168

	51	101	151	201	251	301	351	401	451
1	52	102	152	202	252	302	352	402	452
3	53	103	153	203	253	303	353	403	453
4	54	104	154	204	254	304	354	404	454
5	55	105	155	205	255	305	355	405	455

Reg #		Voter #	Name	Address	Date Iss	Date Ret	WD
0705185990			Voter, Jane Q	10991 W DONNA RD UNIT 221	09/18/20		1
0067589459		1	Voter, Michael R	10991 W DONNA RD UNIT 222	09/18/20		1

- 3 Repeat until all envelopes are counted
Keep envelopes in voter number order

Create a separate pile for ExpressVote ballots or ballots that need reconstruction

Processing ExpressVote Ballots

- 1 Partner 1
 - A. Announce the voter's name
 - B. Number the envelope
 - C. Remove the ballot from the envelope
 - D. Number the ballot

The form contains the following fields and handwritten entries:

- Ward or style number(s): 1
- Ballot Issued by: _____
- Initials of election inspectors: _____
- Absentee Issued by: CWV
- Initials of municipal clerk or deputy clerk (if issued by SVDs, both SVDs must initial.): _____

Handwritten numbers: '1' in the top left, '7' and 'D' in the top right.

- 2 Partner 2
 - A. Announce the voter number
 - B. Cross the number off the voter number sheet
 - C. Record the number on the Absentee Voter Log

! KEEP EXPRESSVOTE BALLOTS IN A SEPARATE PILE FROM THE OFFICIAL BALLOTS

Processing Emailed Ballots

- 1 Partner 1
 - A. Check for
 - ▶ Voter signature
 - ▶ Witness signature
 - ▶ Witness address
 - B. Open the envelope attached to the certificate
 - C. Remove the ballot from the envelope
 - D. Announce the voter's name
 - E. Number the envelope
 - F. Number the ballot
 - G. Certificate and envelope are added to Official Ballot envelopes stack
 - H. Place the ballot in a separate pile to be reconstructed

The form includes the following sections and handwritten entries:

- OFFICIAL ABSENTEE BALLOT APPLICATION/VERIFICATION**
- CERTIFICATION OF SIGNATURE**: Includes a signature and the date 10-1-20.
- CERTIFICATION OF ADDRESS**: Includes a signature and the date 7-9-1968.
- 123 WEST ST. FURNACE, VT.**
- A**: A large handwritten letter 'A' is placed over the bottom portion of the form.

! EMAILED BALLOTS HAVE TO BE RECONSTRUCTED, SEE PAGE 8

- 2 Partner 2
 - A. Announce the voter number
 - B. Cross the number off the voter number sheet
 - C. Record the number on the Absentee Voter Log

Rejected Ballots

Envelopes are rejected for missing:

- Voter signature
- Witness signature
- Witness address

▶ Should already be marked for rejection in red marker ink or red rejection stamp at the beginning the batch of envelopes

▶ Double check to make sure any have not been missed

⇒ If the Election Commission has not already marked an envelope to be rejected, please confirm with a Central Count Manager

▶ These ballots are not assigned a voter number



1 Record them as "RAB" (Rejected Absentee Ballots) on the GAB-104 with a reason code

City of Milwaukee Election Commission GAB-104

Incident Number	DESCRIPTION OF INCIDENT	Time Incident Occurred	Chief Inspector Initials
Tally of Ballots Requiring Override			
Blank:			
Overvote:			
ROB - Reconstructed Official Ballot Codes D - Damaged P - Pencil/Pen Marks OS - Overseas (Federal only ballot) E - Emailed Reg Ballot OTH - Other w/explanation (provide)			
RAB - Rejected Absentee Ballot Certificate Envelope Codes NWS - No Witness Signature NVS - No Voter Signature T - Tampered/Taped NWA - No Witness Address OTH - Other w/explanation (provide)			
RAB 1	Jane Voter NWA		CWV/ML

2 Write on the outside of the envelope "RAB1"
 * RAB (Rejected Absentee Ballot)
 * Number each sequentially RAB-1, RAB-2, etc.

3 Rejected Envelopes
 ▶ Place the "Rejected" unopened envelope containing the ballot in the Goldenrod Envelope

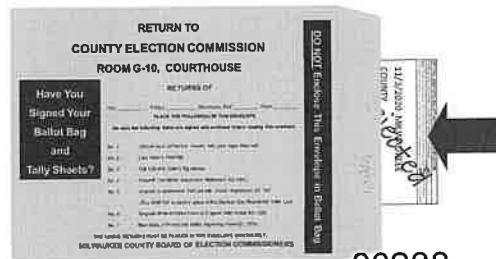
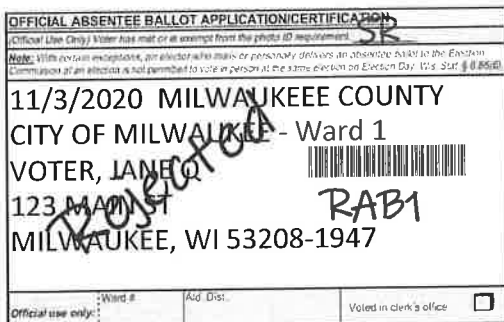

00288

Reconstructing a Ballot

If you open a ballot and it is visibly damaged (torn, crinkled, stained, etc.) or sent via email (not an official ballot) will have to reconstruct the ballot with your partner.

- ▶ **Both partners must always be present when reconstructing a ballot**
- ▶ **After you have assigned all your voter numbers for the ward, you should then reconstruct ballots**
- ▶ **Count the number of ballots that you need to reconstruct for the ward and get blank ballots from the Central Count Ballot Station**

1 Partner 1

- A. Announce the voter's name
- B. Number the envelope
- C. Remove the ballot from the envelope
- D. Number the ballot
- E. Place the ballot into a separate pile for reconstruction
- F. Keep the envelope (or certificate statement) with the other envelopes already processed

2 Partner 2

- A. Announce the voter number
- B. Cross the number off the voter number sheet
- C. Record the number on the Absentee Voter Log

3 Proceed to the Central Count Ballot Station to request the number of ballots that you will need to reconstruct

**The person that issues the ballots will have initialed/stamped with it "CWV" for the issuing authority*

<p style="margin: 0;">Absentee ballot issued by / Papeleta de voto ausente emitida por CWV</p> <hr style="border: 0; border-top: 1px solid black; margin: 5px 0;"/> <p style="margin: 0; text-align: center;">Intials of Municipal Clerk or Deputy Clerk Iniciales de secretario municipal o secretario suplente</p> <hr style="border: 0; border-top: 1px solid black; margin: 5px 0;"/> <p style="margin: 0; text-align: center;">If issues by SVDs, both must initial Si es emitida por SVDs, ambos deben firmar</p>
--

4 For each ballot, determine why you are reconstruction the ballot:

Reason	Code
Emailed Ballot	E
Damaged	D
Overseas (Federal Only Ballot)	OS
Pencil/Pen Marks (Not Fully Scanned)	P
Wrong Ward*	WW

** If the ballot was for the wrong ward, you will need to reconstruct the ballot with votes only for the races that are in both wards*

Reconstructing a Ballot

- 5 Record them as "ROB" (Reconstructed Official Ballot) on the GAB-104 with:
- The voter's number
 - Reason Code
 - Initials

City of Milwaukee Election Commission GAB-104

Incident Number	DESCRIPTION OF INCIDENT	Time Incident Occurred	Chief Inspector Initials
Tally of Ballots Requiring Override			
Blank:			
Overvote:			
ROB - Reconstructed Official Ballot Codes D - Damaged P - Pencil/Pen Marks OS - Overseas (Federal only ballot) E - Emailed Reg Ballot OTH - Other w/explanation (provide)			
RAB - Rejected Absentee Ballot Certificate Envelope Codes NWS - No Witness Signature NVS - No Voter Signature T - Tampered/Taped NWA - No Witness Address OTH - Other w/explanation (provide)			
ROB 1	#34 D		CWV/ML

- 5 On the **original** ballot:
- A. Select the reason for reconstruction
 - B. Write the ROB#
 - C. Write your initials and your partner's initials

- On the **reconstructed** ballot:
- A. Write the ROB#
 - B. Write your initials and your partner's initials

For Official Use Only

A Inspectors: Identify ballots required to be remade:

Overvoted

Damaged

Other

If this is the Original Ballot , write the serial number here: <u>ROB1</u>	If this is the Duplicate Ballot , write the serial number here: _____
B _____	A _____
C <u>CWV</u>	<u>ML</u>

Initials of inspectors who remade ballot

For Official Use Only

Inspectors: Identify ballots required to be remade:

Overvoted

Damaged

Other

If this is the Original Ballot , write the serial number here: _____	If this is the Duplicate Ballot , write the serial number here: <u>ROB1</u>
B _____	A _____
<u>ML</u>	<u>CWV</u>

Initials of inspectors who remade ballot

Reconstructing a Ballot

- 7 On the **reconstructed** ballot:
Write the voter's number

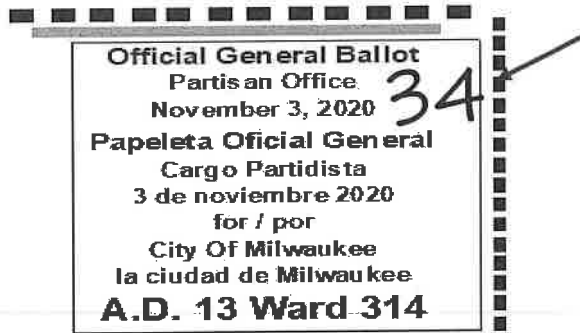

- 8 Hand your partner the **original** ballot
Partner 1:

▶ Read off the votes as the voter recorded

County / Condado	
County Clerk Secretario del Condado	
Vote for 1 / Vote por 1	
<input checked="" type="radio"/>	George Washington (Democratic)
<input type="radio"/>	write-in / por escrito:

Partner 2:

▶ Fill in votes on the ballot as the votes

County / Condado	
County Clerk Secretario del Condado	
Vote for 1 / Vote por 1	
<input checked="" type="radio"/>	George Washington (Democratic)
<input type="radio"/>	write-in / por escrito:

- 9 Hand **both** ballots to Partner 1
Partner 1:

Verify the reconstructed ballot matches

Original

County / Condado	
County Clerk Secretario del Condado	
Vote for 1 / Vote por 1	
<input checked="" type="radio"/>	George Washington (Democratic)
<input type="radio"/>	write-in / por escrito:

Reconstructed

County / Condado	
County Clerk Secretario del Condado	
Vote for 1 / Vote por 1	
<input checked="" type="radio"/>	George Washington (Democratic)
<input type="radio"/>	write-in / por escrito:

- 10 Refold and place the **original** ballot in the Goldenrod Envelope

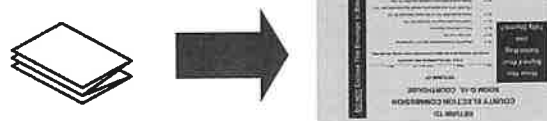

- 11 The **reconstructed** ballot is added to the stack of Official Ballots

Completed Work

- 1 Bundle all empty Absentee Envelopes in the order they were processed (voter number) with a rubber band and place them in the bin provided

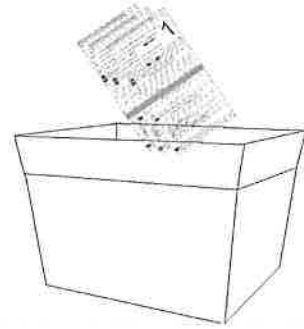

- 2 Initial the last voter number on the Voter Number Sheet

74	74	124	174
75	75 ML	125	175
76	76	126	176

- 3 Attempt to flatten the ballots
- Bend them at the scored folds
 - Roll them in different directions

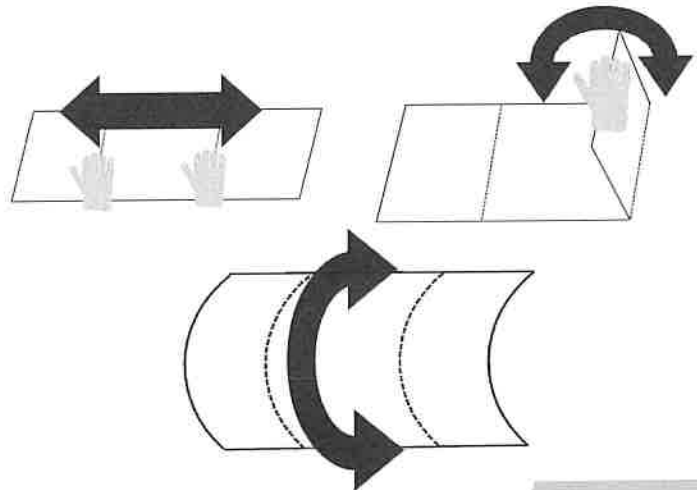

- 4 Prepare your processed ballots and paperwork to have them counted

A. Put the Ballot Bag, Voter Log, Ward Sign, Voter Number Sheet, Write-in Form, and GAB-104 back into the Goldenrod Envelope

B. Place the filled Goldenrod Envelope underneath the ballots

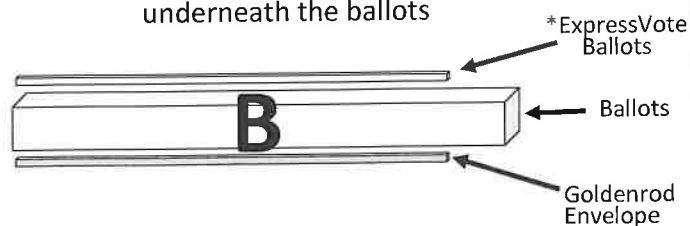
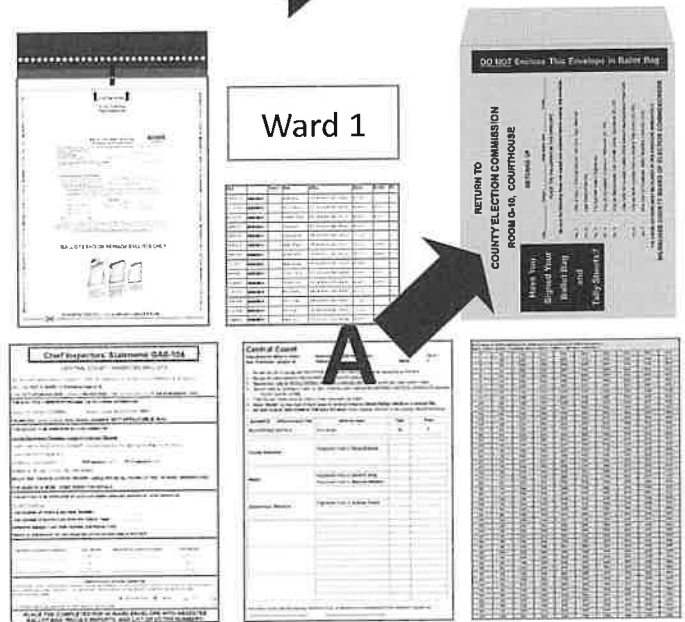

- 5 Take your ready to be counted work to the assigned counting station

Role	Name	Phone	Email	Notes
Ballot Prep Table 1 - A				
Ballot Prep Table 1 - B				
Ballot Prep Table 2 - A				
Ballot Prep Table 2 - B				
Ballot Prep Table 3 - A				
Ballot Prep Table 3 - B				
Ballot Prep Table 4 - A				
Ballot Prep Table 4 - B				
Ballot Prep Table 5 - A				
Ballot Prep Table 5 - B				
Ballot Prep Table 6 - A				
Ballot Prep Table 6 - B				
Ballot Prep Table 7 - A				
Ballot Prep Table 7 - B				
Ballot Prep Table 8 - A				
Ballot Prep Table 8 - B				
Ballot Prep Table 9 - A				
Ballot Prep Table 9 - B				
Ballot Prep Table 10 - A				
Ballot Prep Table 10 - B				
Ballot Prep Table 11 - A				
Ballot Prep Table 11 - B				
Ballot Prep Table 12 - A				
Ballot Prep Table 12 - B				
Ballot Prep Table 13 - A				
Ballot Prep Table 13 - B				
Ballot Prep Table 14 - A				
Ballot Prep Table 14 - B				
Ballot Prep Table 15 - A				
Ballot Prep Table 15 - B				
Ballot Prep Table 16 - A				
Ballot Prep Table 16 - B				
Ballot Prep Table 17 - A				
Ballot Prep Table 17 - B				
Ballot Prep Table 18 - A				
Ballot Prep Table 18 - B				
Ballot Prep Table 19 - A				
Ballot Prep Table 19 - B				
Ballot Prep Table 20 - A				
Ballot Prep Table 20 - B				
Ballot Prep Table 21 - A				
Ballot Prep Table 21 - B				

Ballot Prep Table 22 - A
Ballot Prep Table 22 - B
Ballot Prep Table 23 - A
Ballot Prep Table 23 - B
Ballot Prep Table 24 - A
Ballot Prep Table 24 - B
Envelope Opener 1
Envelope Opener 2
Envelope Opener 3
Envelope Opener 4
DS200 Tabulator 1
DS200 Tabulator 2
DS450 Tabulator - A
DS450 Tabulator - B
Reconstructor Table 1 - A
Reconstructor Table 1 - B
Reconstructor Table 2 - A
Reconstructor Table 2 - B
Ballot Runner & Flattener - A
Ballot Runner & Flattener - B
Ballot Sorter
Dropbox Ballot Receiver

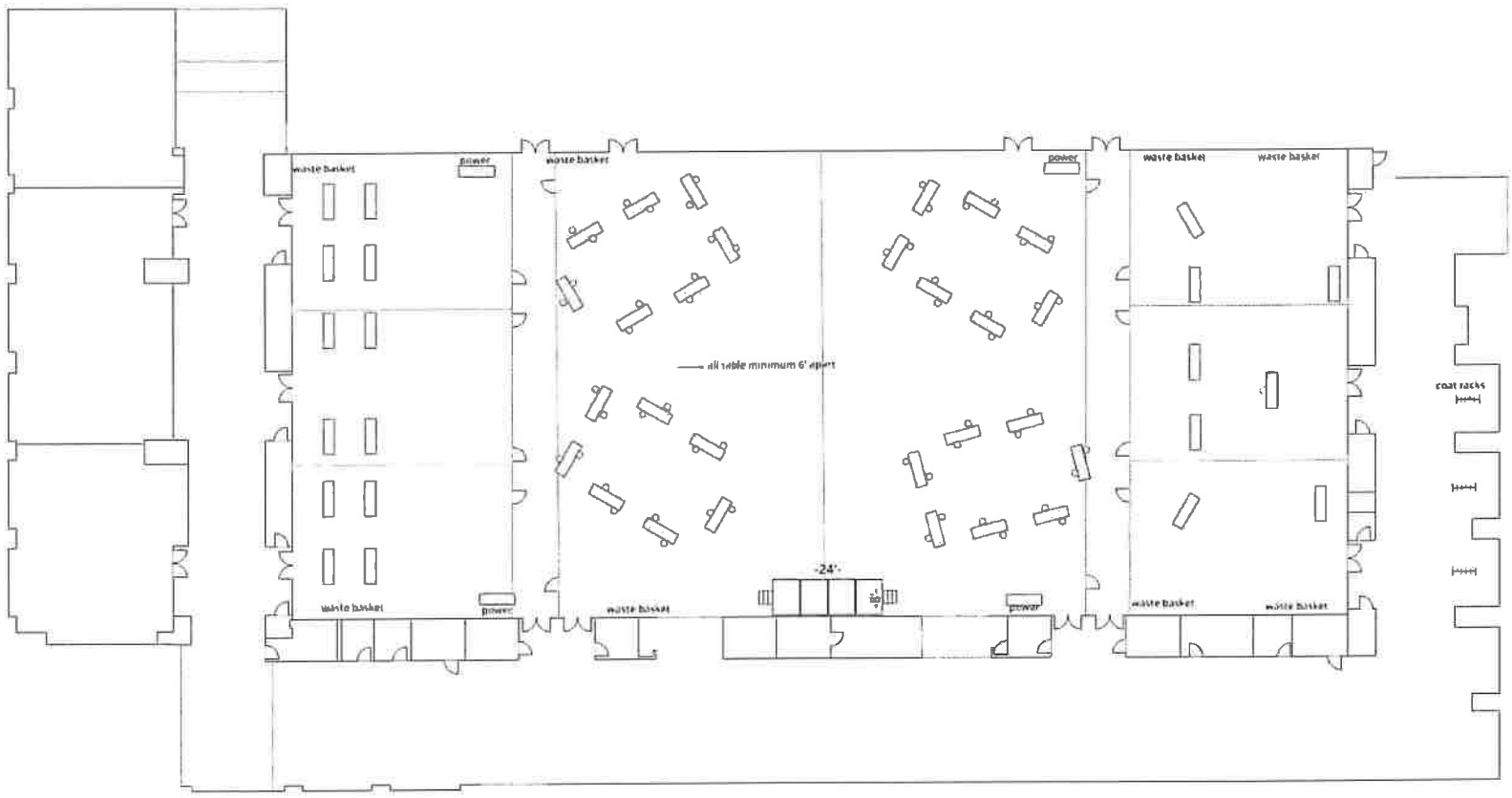

20 Feet

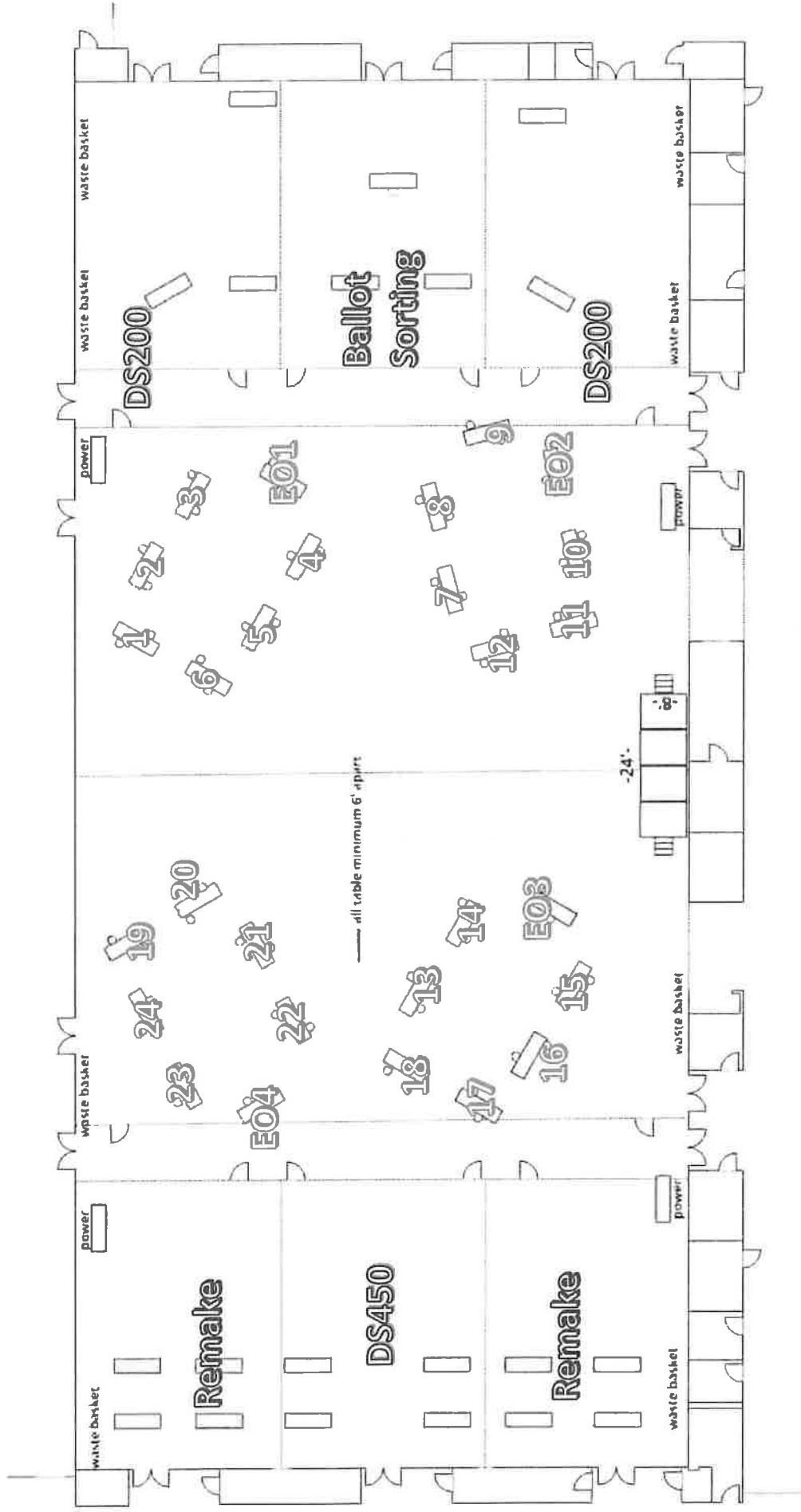

Deanna Debruler

From: Michael Spitzer-Rubenstein <michael@voteathome.org>
Sent: Tuesday, October 27, 2020 8:10 PM
To: Vanessa Chavez
Cc: Celestine Jeffreys; Diana Ellenbecker; Kim Wayte
Subject: Re: Ballot Receipt and Central Count

Thanks, Vanessa. I'm just nervous about how the WEC interprets the statute because other cities are operating differently.

Michael

On Tue, Oct 27, 2020 at 7:12 PM Vanessa Chavez <Vanessa.Chavez@greenbaywi.gov> wrote:

Hi Michael,

As I noted on the call, I reached out to the WEC with my interpretation of Wis. Stat. 7.52(1)(a), which specifically references receipt by the municipal clerk, not central count. I informed them that we are still looking for additional guidance to ensure there are no unnecessary challenges as a result. They responded that they will review and get us an answer shortly. I have not heard anything.

Vanessa

Vanessa R. Chavez, *City Attorney*

City of Green Bay

(920) 448-3080

Vanessa.Chavez@greenbaywi.gov

LEGAL DISCLAIMER: This message and all attachments may be confidential or protected by privilege. If you are not the intended recipient, you are hereby notified that any disclosure, copying, distribution or use of the information contained in or attached to this message is strictly prohibited. Please notify the sender of the delivery error by replying to this message, and then delete it from your system. Thank you.

From: Michael Spitzer-Rubenstein [mailto:michael@voteathome.org]
Sent: Tuesday, October 27, 2020 6:22 PM
To: Vanessa Chavez <Vanessa.Chavez@greenbaywi.gov>
Subject: Ballot Receipt and Central Count

Hi Vanessa, have you been able to get an answer from the WEC about whether we can receive ballots at City Hall before 8 PM and then move them to Central Count after 8?

I'm very concerned that we're walking into potential issues.

Thanks,

Michael

--
Michael Spitzer-Rubenstein

State Lead for Wisconsin (Leadership Now Fellow)

National Vote at Home Institute

(310) 980-2872

he/him



Learn more about:

[Election Officials Center](#)

[Mail Ballot FAQs](#)

[Mail Ballot Security](#)

--
Michael Spitzer-Rubenstein
State Lead for Wisconsin (Leadership Now Fellow)
National Vote at Home Institute
(310) 980-2872
he/him



Learn more about:
[Election Officials Center](#)

Deanna Debruler

From: Michael Spitzer-Rubenstein <michael@voteathome.org>
Sent: Thursday, October 29, 2020 8:49 AM
To: Vanessa Chavez
Cc: Amaad Rivera; Celestine Jeffreys
Subject: Fwd: legal context on accepting ballots at central count after 8pm

Vanessa, Celestine,
Want to make sure you see this.

Michael

----- Forwarded message -----

From: Sam Munger [REDACTED]
Date: Wed, Oct 28, 2020 at 6:10 PM
Subject: legal context on accepting ballots at central count after 8pm
To: Michael Spitzer-Rubenstein <michael@voteathome.org>, Amaad Rivera <amaadr@gmail.com>

Hey Amaad, Michael - I've been doing some digging on the dropbox closing time issue and thought I'd share what I've found out in case it's of help in formulating your plans. Feel free to give me a call to discuss, or to have the City Attorney's office reach out to me directly.

-SM

Here is what the WEC guidance on the issue (<https://elections.wi.gov/sites/elections.wi.gov/files/2020-10/Election%20Night%20Results%20Clerk%20Memo%20FINAL.pdf>) says: "absentee ballots must be delivered to the polling place or the central count facility by 8 p.m. on election night in order to be counted. This means that if a municipality has drop boxes or other drop off locations, the last pick up time needs to be properly noticed to the public to ensure that all ballots eligible to be counted are delivered to the polling place or central count facility no later than 8 p.m." So that seems fairly clear.

But both Ann Jacobs and Nate Judnic at the WEC have acknowledged the statutory scheme is a little more ambiguous. They are relying on the language in Wis State 6.87(6), (<https://docs.legis.wisconsin.gov/statutes/statutes/6/iv/87/6>), which says that "The ballot shall be returned so it is delivered to the polling place no later than 8 p.m. on election day. ...Any ballot not mailed or delivered as provided in this subsection may not be counted." They think that reading that strictly, as a best practice and to be consistent with those municipalities that count absentee ballots at the polling place, means that a municipality should get all dropbox ballots to a central count facility by 8pm.

That said, Nate acknowledged that based on the language in 7.52 (<https://docs.legis.wisconsin.gov/statutes/statutes/7/ii/52>) there is an argument that such ballots just need to be "received by the municipal clerk" by 8pm which is different than being at central count by 8pm. However, **that argument has not been tested and any municipality that relies on it would have to be prepared for a possible challenge to any ballots arriving at central count after 8pm, and for those ballots not to count if they lost in court.** So, the WEC's guidance erred on the side of safety, and that's what we are recommending municipalities do.

That said, Claire in Milwaukee is taking the approach that, should something interfere with ballots arriving by 8pm to central count from a dropbox (e.g. retrieval team blocked by car accident, protest, etc), she is ready and willing, if challenged, to make a legal argument that the ballots should still be accepted. Essentially, she believes there's a strong legal argument for accepting delayed ballots (voted at the dropbox, picked up before 7:30pm, but not back at central count), and her default will be to accept them after 8pm if they're coming from dropboxes.

That being said, she is sticking with closing the dropboxes at 7:30pm -- so there's still the issue of the 7:30-8pm voters, who will need to go directly to central count or their nearest precinct. (Deadline has been updated on official materials, a postcard has gone out with the new deadline to all absentee voters that have yet to submit their ballots, and Sam M is exploring having volunteers at the dropboxes at 7:30pm to help voters navigate their options once the dropboxes are closed.)

On Wed, Oct 28, 2020 at 11:53 AM Wittenwyler, Mike <mwittenw@gklaw.com> wrote:

Spoke to Nate at the WEC.

As a best practice and to be consistent with those municipalities that count absentee ballots at the polling place, a municipality should get all dropbox ballots to a central count facility by 8pm. That said, Nate acknowledges the language in 7.52 and the argument that such ballots just need to be "received" by the municipal clerk by 8pm which is different than being at central count by 8pm. However, that argument has not been tested and any municipality that does otherwise needs to recognize a possible challenge to any ballots arriving at central count after 8pm.

And, he closed by saying that the WEC is working to schedule a check-in call with all the central count municipalities in the next day to coordinate activities and answer question.

--
Michael Spitzer-Rubenstein
State Lead for Wisconsin (Leadership Now Fellow)
National Vote at Home Institute
(310) 980-2872
he/him



Learn more about:
[Election Officials Center](#)
[Mail Ballot FAQs](#)
[Mail Ballot Security](#)

Deanna Debruler

From: Michael Spitzer-Rubenstein <michael@voteathome.org>
Sent: Monday, November 2, 2020 12:48 PM
To: Celestine Jeffreys
Cc: Diana Ellenbecker; Eric Genrich; Ilana Walder-Biesanz; Jaime Fuge; Kim Wayte
Subject: Re: WisVote Data

Hi Kim and Jaime, would you be able to pull the numbers on the absentee ballots returned and outstanding per ward?

If you want to just export the Excel files for the absentee ballot report, we can work with that. Ilana from the Vote at Home team will work to balance the loads so that each table has a similar number of ballots to prepare.

In addition, have you figured out which wards will be on the DS200? If not, we can do that too.

Thanks,
Michael

On Fri, Oct 30, 2020 at 4:31 PM Celestine Jeffreys <Celestine.Jeffreys@greenbaywi.gov> wrote:

Hello!

I think it would be important for “us” (the clerk’s office) to pull data from WisVote which would tell us, the number of registered voters, the absentee ballot requests and returns per ward.

Kim has done a fabulous job keeping us posted on the daily totals. As we head into Election Day, it would be profitable for us to understand where we will need or require Election Day poll workers, and then also the allocation of ward assignments for Central Count.

Please let me know how I can help collect this data.

Thanks!!

Celestine



Celestine Jeffreys

Chief of Staff



Office of the Mayor

920.448.3006

--

Michael Spitzer-Rubenstein

State Lead for Wisconsin (Leadership Now Fellow)

National Vote at Home Institute

(310) 980-2872

he/him



Learn more about:

[Election Officials Center](#)

[Mail Ballot FAQs](#)

[Mail Ballot Security](#)

Deanna Debruler

From: Michael Spitzer-Rubenstein <michael@voteathome.org>
Sent: Monday, November 2, 2020 12:48 PM
To: Celestine Jeffreys
Cc: Diana Ellenbecker; Eric Genrich; Ilana Walder-Biesanz; Jaime Fuge; Kim Wayte
Subject: Re: WisVote Data

Hi Kim and Jaime, would you be able to pull the numbers on the absentee ballots returned and outstanding per ward?

If you want to just export the Excel files for the absentee ballot report, we can work with that. Ilana from the Vote at Home team will work to balance the loads so that each table has a similar number of ballots to prepare.

In addition, have you figured out which wards will be on the DS200? If not, we can do that too.

Thanks,
Michael

On Fri, Oct 30, 2020 at 4:31 PM Celestine Jeffreys <Celestine.Jeffreys@greenbaywi.gov> wrote:

Hello!

I think it would be important for “us” (the clerk’s office) to pull data from WisVote which would tell us, the number of registered voters, the absentee ballot requests and returns per ward.

Kim has done a fabulous job keeping us posted on the daily totals. As we head into Election Day, it would be profitable for us to understand where we will need or require Election Day poll workers, and then also the allocation of ward assignments for Central Count.

Please let me know how I can help collect this data.

Thanks!!

Celestine

Deanna Debruler

From: Michael Spitzer-Rubenstein <michael@voteathome.org>
Sent: Friday, October 30, 2020 1:27 PM
To: Amaad Rivera; Jaime Fuge; Diana Ellenbecker; Kim Wayte; Celestine Jeffreys
Subject: Revised Central Count Roles
Attachments: Central Count Poll Worker Needs v2.xlsx

As discussed this morning:

65 people for shift 1 (6 AM - 3 PM)
65 people for shift 2 (2 PM - 11 PM)
25 people for shift 3 (10 PM - close)

I think the one big remaining question is just delivering the machines over to KI on Monday but I know, Diana, that you're working on it.

Michael

--

Michael Spitzer-Rubenstein
State Lead for Wisconsin (Leadership Now Fellow)
National Vote at Home Institute
(310) 980-2872
he/him



Learn more about:
[Election Officials Center](#)
[Mail Ballot FAQs](#)
[Mail Ballot Security](#)

Calculation: Time/staff to process ballots with available equipment Calculated using 'Inputs' and 'Ballot return model' tabs. Update assumptions to change these estimates

Assumptions		
Scenario for VBM policy & communications:	Promoted VBM	
Total turnout:	48,701	
Total mail ballots returned:	34,150	Adjust in the 'Ballot request model' and 'Ballot return model' tabs
Implied % VBM	73%	i.e., 59% of registered voters will vote by mail.
Implied % in-person	27%	
Mail ballots returned on deadline/Election Day:	6,830	
Election Day as % of all VBM returns	20%	
Operations run 16 hours per day.		

	All available equipment & staff	Off-peak equipment and staffing
Equipment / Staff		
Barcode scanners (for marking as returned)	2	3
Laptops (for signature verification)	2	3
Ballot sorting workers	2	1
Ballot extractors	1	0
Ballot preparation teams	12	0
Ballot scanners (DS-450)	1	0
Ballot scanners (DS-200)	15	0
Ballot reconstruction staffing level	14	0

Process summary		
Projected bottleneck for inbound ballot processing:		
Monday & Election Day (peak volume)	Days/weeks before (off-peak volume)	
Signature verification		Inbound ballots sorted

Potential staffing levels:		
Monday & Election Day (peak volume)	Days/weeks before (off-peak volume)	
Marking ballots as returned	2	3
Signature verification	2	3
Inbound ballots sorted	2	1
Ballots extracted	2	0
Ballot preparation	24	0
Ballots scanned	32	0
Ballots reconstructed	14	0
# of processing staff, per shift	78	7
X # of shifts, per day	2	1
Processing staff	156	7

Monday & Election Day (peak volume)	Days/weeks before (off-peak volume)	
+ Other roles (check-in, etc.)	2	1
+ Supervisors / team captains	4	2
# of other staff, per shift	6	3
X # of shifts, per day	2	1
Other staff	12	3
Total staff	168	10

1. How long will it take to process mail ballots on Election Day? Analyze the time required to process all returned mail ballots with pre-election signature certification and sorting, given available equipment.

Target # of ballots returned on Election Day: 6,830
 Time to Begin Scanning Ballots: 8:00 AM

Equipment / Staff	# of units available / average staffing level	Machine processing capacity (ballots/hour/unit)	Process assumptions	Potential processing capacity (ballots/hour)
Barcode scanners (for marking as returned)	2	1200	Each worker can mark 1200 ballots per hour as returned.	2400
Laptops (for signature verification)	2	1200	Each worker can verify 300 ballot signatures per hour.	2400
Ballot sorting workers	2	1200	Each worker can process 600 ballots/hour by hand.	2400
Ballot extractors	1	12000	Each ballot extractor unit can open 12000 envelopes per hour.	12000
Ballot preparation teams	12	250	Each team can number, flatten, and prepare 250 ballots for scanning, per hour.	3000
Ballot scanners (DS-450)	1	360	Each scanner unit can scan 360 ballots per hour.	360
Ballot scanners (DS-200)	15	165	Each scanner unit can scan 165 ballots per hour.	2475
Ballot reconstruction staffing level	14	6	0.5% of ballots require reconstruction, i.e., 171 ballots.	84

Processes	Hours of runtime required
Marking ballots as returned	3
Signature verification	3
Inbound ballots sorted	3
Ballots extracted	3
Ballot preparation	12
Ballots scanned	13
Ballots reconstructed	13
Processing hours required	13
Days to complete processing task:	0.8
Completion time (non-stop):	11/3/20 9:00 PM

2. How long will it take to process all mail ballots on Election Day using available equipment? Analyze the time required to process all returned mail ballots on Election Day, given available equipment.

Equipment / Staff	# of units available / average staffing level	Machine processing capacity (ballots/hour/unit)	Process assumptions	Potential processing capacity (ballots/hour)
Barcode scanners (for marking as returned)	2	1200	Each worker can mark 1200 ballots per hour as returned.	2400
Laptops (for signature verification)	2	300	Each worker can verify 300 ballot signatures per hour.	600
Ballot sorting workers	2	600	Each worker can process 600 ballots/hour by hand.	1200
Ballot extractors	1	6000	Each ballot extractor unit can open 12000 envelopes per hour.	6000
Ballot preparation teams	12	250	Each team can number, flatten, and prepare 250 ballots for scanning, per hour.	3000
Ballot scanners	15	165	Each scanner unit can scan 165 ballots per hour.	2475
Ballot reconstruction staffing level	14	6	0.5% of ballots require reconstruction, i.e., 171 ballots.	84

Processes	Hours of runtime required
Marking ballots as returned	15
Signature verification	57
Inbound ballots sorted	29
Ballots extracted	6
Ballot preparation	12

Ballots scanned	14
Ballots duplicated	3
Processing hours required	57
Days to complete processing task:	3.6

3. How long will it take to complete mail ballots using available equipment?
 Analyze the time required to process a specified amount of mail ballots, given available equipment.

Target # of ballots: 20,000

Equipment / Staff	# of units available / average staffing level	Machine processing capacity (ballots/hour/unit)	Process assumptions	Potential processing capacity (ballots/hour)
Barcode scanners (for marking as returned)	2	1200	Each worker can mark 1200 ballots per hour as returned.	2400
Laptops (for signature verification)	2	300	Each worker can verify 300 ballot signatures per hour.	600
Ballot sorting workers	2	600	Each worker can process 600 ballots/hour by hand.	1200
Ballot extractors	1	6000	Each ballot extractor unit can open 12000 envelopes per hour.	6000
Ballot preparation teams	12	250	Each team can number, flatten, and prepare 250 ballots for scanning, per hour.	3000
Ballot scanners	15	165	Each scanner unit can scan 165 ballots per hour.	2475
Ballot reconstruction staffing level	14	6	0.5% of ballots require reconstruction, i.e., 100 ballots.	84

Processes	Hours of runtime required
Marking ballots as returned	9
Signature verification	34
Inbound ballots sorted	17
Ballots extracted	4
Ballot preparation	7
Ballots scanned	9
Ballots duplicated	2
Processing hours required	34
Days to complete processing task:	2.1

4. How much time is needed to process returned ballots as they arrive each day?
 Analyze your capacity to process an individual day's volume of returned ballots.

Daily hours of operation: 16
 Days before Election Day: Election Day
 Target # of ballots: 6,830

Equipment	# of units available / average staffing level	Machine processing capacity (ballots/hour/unit)	Process assumptions	Potential processing capacity (ballots/hour)
Barcode scanners (for marking as returned)	2	1200	Each worker can mark 1200 ballots per hour as returned.	2400
Laptops (for signature verification)	2	300	Each worker can verify 300 ballot signatures per hour.	600
Ballot sorting workers	2	600	Each worker can process 600 ballots/hour by hand.	1200
Ballot extractors	1	6000	Each ballot extractor unit can open 12000 envelopes per hour.	6000
Ballot preparation teams	12	250	Each team can number, flatten, and prepare 250 ballots for scanning, per hour.	3000
Ballot scanners	15	165	Each scanner unit can scan 165 ballots per hour.	2475
Ballot reconstruction staffing level	14	6	0.5% of ballots require reconstruction, i.e., 35 ballots.	84

Processes	Hours of runtime required
Marking ballots as returned	3
Signature verification	12
Inbound ballots sorted	6
Ballots extracted	2
Ballot preparation	3
Ballots scanned	3
Ballots duplicated	1
Processing hours required	12
Days to complete processing task:	0.8

5. What is the potential staffing for the week(s) leading up to Election Day?
 Analyze your staffing levels with a reduced / off-peak staffing, for the weeks leading up to Election Day.
 This calculation assumes you can process before Election Day. For jurisdictions where processing is not permitted before Election Day, refer to Sections 1 and 2.

Daily hours of operation: 8
 Days before Election Day: 7 days out
 Target # of ballots: 1,637

Equipment	# of units available / average staffing level	Machine processing capacity (ballots/hour/unit)	Process assumptions	Potential processing capacity (ballots/hour)
Barcode scanners (for marking as returned)	3	1200	Each worker can mark 1200 ballots per hour as returned.	3600
Laptops (for signature verification)	3	300	Each worker can verify 300 ballot signatures per hour.	900
Ballot sorting workers	1	600	Each worker can process 600 ballots/hour by hand.	600
Ballot extractors	0	250	Each ballot extractor unit can open 12000 envelopes per hour.	0
Ballot preparation teams	0	0	Each team can number, flatten, and prepare 250 ballots for scanning, per hour.	0
Ballot scanners	0	165	Each scanner unit can scan 165 ballots per hour.	0
Ballot reconstruction staffing level	0	6	0.5% of ballots require reconstruction, i.e., 8 ballots.	0

Processes	Hours of runtime required
Marking ballots as returned	1
Signature verification	2
Inbound ballots sorted	3
Ballots extracted	0
Ballot preparation	0
Ballots scanned	0
Ballots reconstructed	0
Processing hours required	3
Days to complete processing task:	0.4

Deanna Debruler

From: Michael Spitzer-Rubenstein <michael@voteathome.org>
Sent: Sunday, November 1, 2020 11:59 AM
To: Amaad Rivera; Jaime Fuge
Subject: Ballot Transportation

Hi Jaime, are the ballots going to be in trays/boxes within the bin?

I'm at KI now, trying to figure out whether we'll need to move the bins around throughout the day or if we can just stick them along the wall and use trays or something similar to move the ballots between stations.

Michael

--

Michael Spitzer-Rubenstein
State Lead for Wisconsin (Leadership Now Fellow)
National Vote at Home Institute
(310) 980-2872
he/him



Learn more about:
[Election Officials Center](#)
[Mail Ballot FAQs](#)
[Mail Ballot Security](#)

From: Michael Spitzer-Rubenstein [mailto:michael@voteathome.org]

Sent: Friday, October 30, 2020 10:24 PM

To: Celestine Jeffreys <Celestine.Jeffreys@greenbaywi.gov>; Jaime Fuge <Jaime.Fuge@greenbaywi.gov>; Amaad Rivera <Amaad.Rivera@greenbaywi.gov>; Kim Wayte <Kim.Wayte@greenbaywi.gov>

Subject: Central Count Ballot Tracking Sheets

Hi all,

Sharing the updated versions of the ballot tracking sheets for Central Count:

1. Courier log for City Hall to KI (adjusting the dropbox log)
2. Processing cover sheet (for tracking a batch of ballots from a single ward into the DS450)
3. Reconstruction cover sheet (for tracking ballots that need remaking in a single batch across many wards)

Since we have the processes nailed down and I understand it all now, I'm going to work on the training manual tomorrow.

See you tomorrow,

Michael

--

Michael Spitzer-Rubenstein

State Lead for Wisconsin (Leadership Now Fellow)

National Vote at Home Institute

(310) 980-2872

he/him



Learn more about:

[Election Officials Center](#)

[Mail Ballot FAQs](#)

Deanna Debruler

From: Michael Spitzer-Rubenstein <michael@voteathome.org>
Sent: Monday, November 2, 2020 9:01 AM
To: Celestine Jeffreys
Cc: Diana Ellenbecker; Chris Pirlot; Steven Grenier
Subject: Re: Central Count Set Up Details (DPW)
Attachments: Log - Delivery Open and Close.docx

Hi all, here's the log I put together for moving ballots in the morning and evening.

It's meant to be printed double-sided so each truck will have its own sheet. We'll need to print 4 total, 2 for the morning, 2 for the evening.

Michael

On Fri, Oct 30, 2020 at 4:57 PM Celestine Jeffreys <Celestine.Jeffreys@greenbaywi.gov> wrote:

Celestine Jeffreys is inviting you to a scheduled Zoom meeting.

Join Zoom Meeting

Meeting ID: [REDACTED]

Passcode: [REDACTED]

One tap mobile

+19292056099,,82422490111#,,,,,0#,,763276# US (New York)

+13017158592,,82422490111#,,,,,0#,,763276# US (Germantown)

Dial by your location

+1 929 205 6099 US (New York)

+1 301 715 8592 US (Germantown)

+1 312 626 6799 US (Chicago)

+1 669 900 6833 US (San Jose)

+1 253 215 8782 US (Tacoma)

+1 346 248 7799 US (Houston)

Meeting ID: [REDACTED]

Passcode: [REDACTED]

Find your local number: <https://us02web.zoom.us/j/kmjPjfv6>

--

Michael Spitzer-Rubenstein
State Lead for Wisconsin (Leadership Now Fellow)
National Vote at Home Institute

Deanna Debruler

From: Michael Spitzer-Rubenstein <michael@voteathome.org>
Sent: Thursday, October 29, 2020 11:18 AM
To: Kim Wayte; Jaime Fuge; Diana Ellenbecker
Subject: 15 minutes later today?

Hi Kim,
I'm putting together instructions for the Central Count workers, augmenting your guide with the DS450 instructions. There were just a couple points that I wanted to confirm.

Do you have a few minutes this afternoon to go through the process? I'll make myself available any time you are.

Thanks,
Michael

--

Michael Spitzer-Rubenstein
State Lead for Wisconsin (Leadership Now Fellow)
National Vote at Home Institute

(██████████)

he/him

Learn more about:
[Election Officials Center](#)
[Mail Ballot FAQs](#)
[Mail Ballot Security](#)

What Are Observers NOT Allowed To Do?

Observers must comply with the rules of the Chief Election Inspector or they will be removed.

- DO NOT interfere in any way with the election process.
- DO NOT assist in Central Count operations.
- DO NOT touch election-related material, equipment or election staff.
- DO NOT sit at or stand behind the check-in tables.
- DO NOT communicate with Central Count personnel while they are engaged in a process.
- DO NOT converse with or solicit voters within 100 feet of the Central Count entrance to influence voting or question their qualifications to vote.
- DO NOT speak in a loud voice, cause confusion, or congregate inside a Central Count.
- DO NOT display any election material or wear campaign badges, buttons, or apparel.
- DO NOT wear the uniform of a law enforcement officer, private guard, or security personnel.
- DO NOT use video or cameras in a disruptive way or show how an elector has voted.

Public Observation and Covid-19

In order to protect the health and safety of our community, we may need to limit the number of observers allowed at polling places and Central Count. The Election Inspector of each location has determined how many observers are allowed at their location, based on space constraints and public health guidelines. Please be mindful of others who wish to observe and limit your observation if there are others waiting to observe.

All poll observers must follow COVID-19 precautions as recommended by the Centers for Disease Control and Prevention, including:

- Stay home if you have experienced any symptoms in the last 14 days, including but not limited to fever, chills, nausea, difficulty breathing, cough or fatigue.
- Wear a face covering that covers your nose, mouth, and chin at all times.
- Stay at least 6 feet distance away from others at all times.

Any observers not following these guidelines will be asked to comply or be removed from the observation area.

Remote Observation

To increase access to poll observation with and reduced the risk of transmission, we have set up remote observation of Central Count. A link to the livestream can be found on our website on Election Day. Challenges will only be accepted in person at Central Count. All rules for in-person poll observation remain in place for remote observation, including:

- DO NOT record voter or ballot data.
- DO NOT interfere with the conduct of the election.
- DO NOT use force, violence, or intimidation to compel a person to vote or refrain from voting.



 @voteathome

 www.voteathome.org

 NationalVoteAtHome

Deanna Debruler

From: Michael Spitzer-Rubenstein <michael@voteathome.org>
Sent: Tuesday, November 3, 2020 9:29 PM
To: Vanessa Chavez
Subject: Re: Be prepared: ballots delayed

I think were probably okay; I don't think anyone challenged the ballots when they came in.

On Tue, Nov 3, 2020 at 9:27 PM Vanessa Chavez <Vanessa.Chavez@greenbaywi.gov> wrote:
Thanks for the heads up.

Sent from my iPhone

On Nov 3, 2020, at 8:27 PM, Michael Spitzer-Rubenstein <michael@voteathome.org> wrote:

In case you didn't hear, someone or several people harassed CSOs and prevented one of the dropbox deliveries from getting to City Hall by 8 PM.

We have the delivery logs to establish that they picked the ballots well before 8. Milwaukee is prepared to rely on the same interpretation we're using about the City Hall dropboxes to say that any ballots in the hands of the clerk's agents before 8 PM count.

Want you to be prepared and feel free to give me a call: [REDACTED].

--

Michael Spitzer-Rubenstein
State Lead for Wisconsin (Leadership Now Fellow)
National Vote at Home Institute

[REDACTED]

he/him

[REDACTED]

Learn more about:

[Election Officials Center](#)

[Mail Ballot FAQs](#)

[Mail Ballot Security](#)

--

Michael Spitzer-Rubenstein
State Lead for Wisconsin (Leadership Now Fellow)
National Vote at Home Institute

[REDACTED]

he/him

[REDACTED]

Learn more about:

[Election Officials Center](#)

[Mail Ballot FAQs](#)

Entrance with A-Frame Sign



Entrance with A-Frame Sign

Voter Check-In Stations.
Voter checks in, receives ballot packet and then is instructed to vote at booths in the hallway and to sign their ballot with the clerk at the manned ballot box.



FIRST FLOOR PLAN
SCALE: 3/32" = 1'-0"

Exit with A-Frame Sign

-  Manned Ballot Drop off w/ Clerk
-  Voting Booth
-  Stanchion(s)

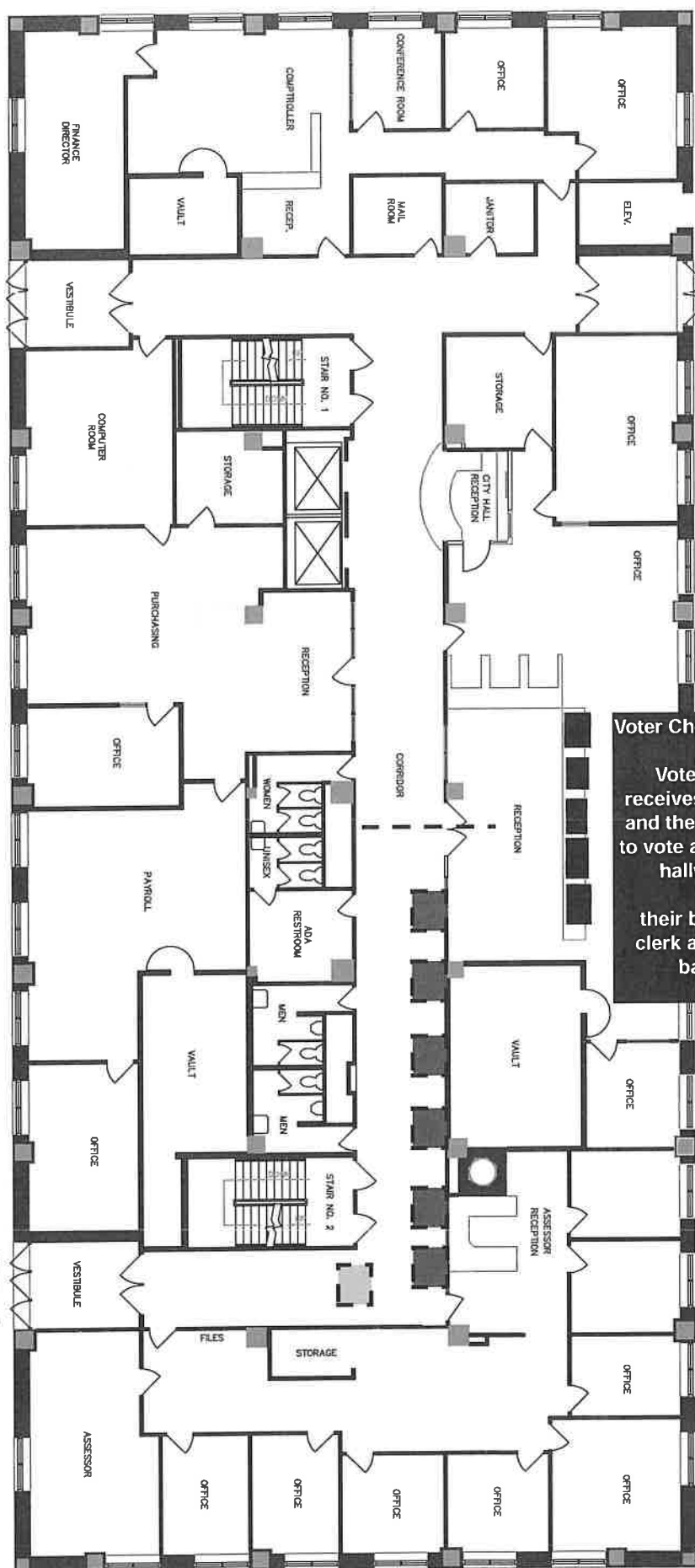

Day	Time	Task	People Needed	Notes		
Monday	PM	Prep ballot bins	Kim and staff			
	TBD	Move machines to KI	DPW or Maintenance	1 DS450, 2 DS200s, 4 envelope opening machines		
	TBD	Move supplies to KI	Amaad and Michael	PPE, badges/stickers, printer, portable dropbox, list of assignments, table signs, pens, training materials, letter openers		
	TBD	KI Setup		2		
Tuesday	6am	Move ballot bins to KI	DPW	Michael at KI to guide		
Shift 1	6am-3pm	Ballot sorting		1 Ideally should be WisVote-trained		
		Envelope Opening Machine Oper:		4 Also floater within pod for breaks		
		Ballot preparation teams		48 24 teams		
		Ballot scanners (DS-450)		2 Diana?		
		Ballot scanners (DS-200)		2 1 for each machine		
		Runners and Ballot Flatteners		2		
		Ballot reconstruction		4 2 teams, should be experienced		
		Supervision and check-in		2 Jaime, Amaad, (also MSR)		
		Shift 1 total		65		
		Shift 2	2pm-11pm	Ballot sorting		1 Ideally should be WisVote-trained
Envelope Opening Machine Oper:				4 Also floater within pod for breaks		
Ballot preparation teams				48 24 teams		
Ballot scanners (DS-450)				2		
Ballot scanners (DS-200)				2 1 for each machine		
Runners and Ballot Flatteners				2		
Ballot reconstruction				4 2 teams, should be experienced		
Supervision and check-in				2 Jaime, Amaad, (also MSR)		
Shift 2 total				65		
Shift 3	10pm-close			Ballot sorting		1
		Ballot preparation teams		12 6 teams		
		Ballot scanners (DS-450)		2		
		Ballot scanners (DS-200)		2 1 for each machine		
		Runners and Ballot Flatteners		2		
		Ballot reconstruction		4 2 teams, should be experienced		
		Supervision and check-in		2 Jaime, Amaad, (also MSR)		
		Shift 3 total		25		
		Close				
		Move ballots to City Hall DPW				
Take memory sticks to City Hall Jaime						



Wisconsin Safe Voting Plan 2020
Submitted to the Center for Tech & Civic Life
June 15, 2020

The State of Wisconsin found itself in the midst of an historic election in April of 2020 when statewide elections occurred in the midst of the COVID-19 pandemic. These elections included not only the presidential preference vote, but also local races for city councils, county boards, school board, and mayors, a statewide election for a seat on the Wisconsin Supreme Court, and numerous district-wide school referenda.

Municipalities were required to make rapid and frequent adjustments to ensure compliance with the rapidly changing Supreme Court, Wisconsin Supreme Court, and Wisconsin Election Commission (WEC) rulings about the election. (The April 2020 Election may go down in history as the only election in which the Wisconsin Supreme Court and the US Supreme Court weighed in on the same day on how the election would be conducted.)

The shifting legal landscape was also complicated by the extraordinary lengths municipal clerks went to to ensure that both voting and election administration were done in accordance with prevailing public health requirements.

As mayors in Wisconsin's five biggest cities - Milwaukee, Madison, Green Bay, Kenosha, and Racine - we seek to work collaboratively on the two remaining 2020 elections (August 11th and November 3rd) to: safely administer elections to reduce the risk of exposure to coronavirus for our residents as well as our election officials and poll workers; identify best practices; innovate to efficiently and effectively educate our residents about how to exercise their right to vote; be intentional and strategic in reaching our historically disenfranchised residents and communities; and, above all, ensure the right to vote in our dense and diverse communities.

Table 1: Summary of Municipalities' Electorate Data, June 2020

	Green Bay	Kenosha	Madison	Milwaukee	Racine
Estimated Eligible Voters	71,661	73,000	213,725	430,000	56,000
Registered Voters	52,064	47,433	178,346	294,459	34,734
2020 Election Budget	\$329,820	\$205,690	\$2,080,283	\$2,986,810	\$409,529

All five jurisdictions share concerns about how to best facilitate voter participation and limit exposure to coronavirus. All five jurisdictions spent all or most of the budgeted resources for all of 2020 on the extraordinary circumstances this Spring. If no plan is approved, it will leave communities like ours with no choice but to make tough decisions between health and the right to vote; between budget constraints and access to fundamental rights. The time that remains between now and the November Election provides an opportunity to plan for the highest possible voter turnouts in the safest possible ways.

We are collectively requesting a total of \$6,324,527 as summarized in Table 3 below and detailed extensively in the plan.

Review of the April 2020 Election

The April 2020 election placed two sacred duties of cities in conflict: keeping our residents safe and administering free and fair elections. Since Wisconsin's elections are administered at the municipal level, each municipality was on its own to deal with these dynamics. Our Municipal Clerks and their staff are all remarkable public servants, who responded nimbly and effectively to marshal the resources needed to run these elections under exceedingly challenging circumstances. In this election, all five of our municipalities faced:

- Precipitous drop-offs of experienced poll workers;
- A scramble to procure enough PPE to keep polling locations clean and disinfected and to mitigate COVID-19 risk for election officials, poll workers, and voters;
- A never-before-seen increase in absentee ballot requests;
- High numbers of voters who struggled to properly submit required photo ID and/or provided insufficient certification of absentee ballot envelopes; and
- Voters who, understandably, were completely confused about the timeline and rules for voting in the midst of a pandemic and required considerable public outreach and individual hand-holding to ensure their right to vote.

See Table 2, below, for detailed data on all five municipalities' April 2020 absentee mail and in-person early voting experiences.

Table 2: Summary of Municipalities' Experiences in April 2020 Election

	Green Bay	Kenosha	Madison	Milwaukee	Racine
# of voters who requested absentee ballots for April election	15,509	16,017	89,730	96,712	11,615
# of absentee ballots successfully cast in April	11,928	13,144	77,677	76,362	9,570
# of absentee ballot requests unfulfilled due to insufficient photo ID	Unknown	Unknown	1,840	2.5%	Estimated hundreds
# of absentee ballots rejected due to incomplete certification	312	196	618	1,671	368
# of secure drop-boxes for absentee ballot return	1	2	3	5	1
# of days of early voting	12	10	19	14	13
Use curbside voting for early voting?	✓	✗	✓	✓	✓
# of voters who voted in-person early absentee	778	85	4,930	11,612	1,543
# of additional staff enlisted for election-related efforts	86	60	225	95	20
\$ spent on PPE	\$2,122	\$13,000	\$6,305	Unknown	Unknown
# of polling locations	2	10	66	5	14
Use drive-thru or curbside voting on Election Day?	✓	✗	✓	✓	✓

Comprehensive Election Administration Needs for 2020

In early June 2020, all five municipal clerks and their staff, with review and support from all five cities' Mayors and Mayoral staff, completed a detailed, multi-page template (attached) providing both data and information about the municipalities' election plans and needs. This Wisconsin Safe Voting Plan 2020 is based on that comprehensive information. All five of our municipalities recommend the following four strategies to ensure safe, fair, inclusive, secure, and professional elections in our communities for the remaining 2020 elections:

Recommendation I: Encourage and Increase Absentee Voting (By Mail and Early, In-Person)

1. Provide assistance to help voters comply with absentee ballot requests & certification requirements
2. Utilize secure drop-boxes to facilitate return of absentee ballots
3. Deploy additional staff and/or technology improvements to expedite & improve accuracy of absentee ballot processing
4. Expand In-Person Early Voting (Including Curbside Voting)

Recommendation II: Dramatically Expand Strategic Voter Education & Outreach Efforts, Particularly to Historically Disenfranchised Residents

Recommendation III: Launch Poll Worker Recruitment, Training & Safety Efforts

Recommendation IV: Ensure Safe & Efficient Election Day Administration

As detailed in this plan, our municipalities are requesting a total of \$6,324,567 to robustly, swiftly, comprehensively, and creatively implement these four strategic recommendations in each of our communities. That request is summarized as follows in Table 3, below, and detailed extensively in the remainder of this plan.

Table 3: Summary of Resources Needed to Robustly Implement All Four Recommendations

Recommendation	Green Bay	Kenosha	Madison	Milwaukee	Racine	Totals
Encourage and Increase Absentee Voting By Mail and Early, In-Person	\$277,000	\$455,239	\$548,500	\$998,500	\$293,600	\$2,572,839
Dramatically Expand Strategic Voter Education & Outreach Efforts	\$215,000	\$58,000	\$175,000	\$280,000	\$337,000	\$1,065,000
Launch Poll Worker Recruitment, Training & Safety Efforts	\$174,900	\$145,840	\$507,788	\$800,000	\$181,500	\$1,810,028
Ensure Safe & Efficient Election Day Administration	\$426,500	\$203,700	\$40,500	\$76,000	\$130,000	\$876,700
Totals:	\$1,093,400	\$862,779	\$1,271,788	\$2,154,500	\$942,100	\$6,324,567

Recommendation I: Encourage & Increase Absentee Voting By Mail and Early, In-Person

Of all the things that need to be done to ensure access and safety at the polls, this is perhaps the most important and timely. It is time, resource, and labor intensive but results in the voter being able to vote by mail or from the relative safety of their car or at a socially distanced and carefully planned early voting site.

Overview of Absentee Voting in Wisconsin

Before discussing our strategies and plans to encourage and increase absentee voting, both by mail and in-person, early voting, it's important to first understand the absentee voting context in Wisconsin.

There are two ways to vote early in Wisconsin: in-person and through the mail. Both are technically called "absentee voting," a phrase held over from a time when absentee voting required you to affirm that you were over 80, ill, or going to be out of the municipality on Election Day. Those requirements no longer exist in the statutes, and people can vote early, or absentee, for any reason. The April 2020 election saw dramatic increases in the number of absentee ballot requests over previous elections.

While for many regular voters, absentee voting - whether completed by mail or early, in-person - is a relatively easy process, our five cities understand that absentee voting does not work easily for all voters. Our communities of color, senior voters, low-income voters without reliable access to the internet, people with disabilities, and students all have legitimate concerns about the absentee voting process.

Voting absentee by mail has been complicated by the fairly recent imposition of state law requiring voters to provide an image of their valid photo ID prior to first requesting an absentee ballot. While this works relatively easily for voters who have valid photo IDs and the technology necessary to upload an image file of that valid ID into the state's myvote.wi.gov website, it does not work well or easily for other voters who do not have valid photo ID (complicated by closure of DMVs due to the pandemic), lack access to reliable internet (also complicated by coronavirus-related closures or reduced hours at libraries and community centers, leaving those residents without regular public internet access that our municipalities normally provide), those who don't have smart phones to take and upload photos, and those who need additional education about what constitutes a valid photo ID. (For example, countless voters in our municipalities attempted to submit "selfies" as valid photo ID. Explaining to them that this was not a valid form of photo ID and instructing them on how to properly submit valid ID took considerable staff time and resources.)

Once the absentee ballot is received, it must be completed correctly to be successfully cast, and there are numerous certification requirements on the absentee ballot envelope; if not correctly completed, the ballot could be rejected. Prior to this April's

election, very small numbers of voters had traditionally chosen to cast ballots by mail. Municipal clerks' offices simply were not prepared and do not have the staffing or technological resources needed to quickly process dramatically higher numbers of absentee ballot requests, troubleshoot problems, answer voter questions, provide information and to expedite the processing of thousands of received absentee ballots on Election Day.

In-person early absentee voting also poses challenges for voters and election administrators. While all of our communities had previously offered early voting locations and hours, April's election required election officials to creatively and quickly expand in-person early voting opportunities, including curbside voting, all while prioritizing necessary COVID-19 precautions.

As indicated by Table 4, below, all five of our municipalities are already experiencing dramatic increases in the number of voters requesting to vote absentee, compared to pre-pandemic, and must procure resources to enable voters in our communities to meaningfully access absentee voting.

Table 4: Absentee Ballots in All Municipalities as of June 2020

	Green Bay	Kenosha	Madison	Milwaukee	Racine
# of voters on permanent absentee list prior to 2/18/20	1,628	1,856	2,062	6,252	613
# of voters on permanent absentee list as of 4/7/20	4,306	3,469	8,665	23,374	2,684
# of voters who have already requested absentee ballots for August 2020	5,162	9,450	36,092	53,438	3,389
# of voters who have already requested absentee ballots for November 2020	4,859	9,123	34,164	50,446	3,204

We are committed to making voting accessible via mail, in-person prior to Election Day, and at the polls on Election Day. Particularly in the midst of a global pandemic when many voters are rightfully apprehensive about in-person voting, we want to ensure that voters in our communities know they have options and we are committed to conducting the necessary voter outreach and education to promote absentee voting and encourage higher percentages of our electors to vote absentee.

Increasing the number of voters who cast votes prior to Election Day minimizes the risk of spreading COVID-19 on Election Day from in-person contacts at our polling locations, and it reduces the chance for lines and delays in voting on Election Day.

The Wisconsin Election Commission (WEC) has approved a proposal to mail all registered voters absentee ballot request forms, which allows our five communities to focus on helping voters overcome the barriers to successfully returning those forms so they can obtain, and then successfully submit, their completed absentee ballots. This measure will provide absentee request information directly to voters, alleviating the need for municipalities to expend the cost to send the mailing. However, it is unclear how this measure will affect the workload of municipal clerks. Although the WEC has directed that the forms be returned to the WEC for entry, municipal clerks must still review each record, process, mail, record receipt and canvass each absentee ballot.

All of our municipalities anticipate continued large increases in absentee voting based on the April 2020 trends. Milwaukee, for example, anticipates that 80% of residents will vote absentee by mail for both the August primary and the November general election.

All five cities have identified numerous barriers to successful absentee voting, including: voters facing numerous challenges to successfully submitting valid photo ID; voters needing assistance complying with absentee ballot certification requirements, including obtaining the required witness signature on the absentee ballot return envelope; the labor-intensive process faced by all of our clerks' offices of processing absentee ballot requests; and U.S. Postal Service errors and mail delays. All of these are challenges for our municipalities in normal elections, but they are all compounded by the coronavirus pandemic, and made exponentially more difficult by the unprecedented volume of absentee voting requests. This puts tremendous strain on municipal election clerks and their staff.

Our five cities share the desire to assist as many residents as possible with casting ballots before Election Day, serving as the greatest opportunity we have to mitigate the spread of COVID-19 in our communities. We have identified several strategies to help voters in each of our communities overcome these barriers to successful absentee voting, both by mail and in-person early voting.

Overall, our five communities are requesting **\$2,572,839** in resources related to enabling our municipalities to overcome these particular barriers and ensure that our voters can meaningfully access absentee voting, both by mail and in-person early voting. These strategies and resource needs are broken down into four distinct component recommendations, within the overall umbrella of increasing and encouraging absentee voting:

1. **Provide assistance to help voters comply with absentee ballot requests & certification requirements**

- **Green Bay:** The City would like to employ bilingual LTE “voter navigators” (\$45,000) to help residents properly upload valid photo ID, complete their ballots and comply with certification requirements, and offer witness signatures. These voter navigators can assist voters prior to the elections and then also be trained and utilized as election inspectors. They would also like to utilize paid social media and local print and radio advertising to educate and direct voters in how to upload photo ID and how to request and complete absentee ballots. (\$2,000)
Total: \$47,000
- **Kenosha:** The City would like to have Clerk’s staff train library staff on how to help residents request and complete absentee ballots, would like to produce (\$3,000) and mail (\$26,200) a bilingual absentee ballot instruction sheet with all absentee ballots to increase correctly completed and submitted ballots. The City would like to hire a trainer for seasonal election workers, volunteers and poll workers. This employee would also coordinate assignments to polling locations, the early driver up voting site, the Clerk’s office for assistance in processing, data entry and filing of absentee requests and the Absentee Board of Canvassers (approximately \$50,000). The increase in absentee ballots due to COVID-19 has tremendously increased the workload of the department. In order to properly serve the citizens and voters additional LTE employees are needed (approximately \$175,000). **Total: \$254,200**
- **Madison:** Plans to hold curbside “Get your ID on File” events with the Clerk this summer utilizing volunteers or paid poll workers (\$15,000) equipped with PPE (estimated \$5,000) and digital cameras (\$4,500) to capture voter ID images for voters who are unable to electronically submit their IDs to the Clerk’s office. They also need large flags to draw attention to these curbside sites (\$4,000). Would also like mobile wifi hotspots and tablets for all of these sites (\$100,000) so voters could complete their voter registration and absentee requests all at once, without having to wait for staff in the Clerk’s office to follow up on paper forms. (These mobile wifi hotspots, tablets, and flags, could all then be repurposed for early in-person voting closer to the election.) **Total: \$128,500**
- **Milwaukee:** The City notes that the biggest obstacle to Milwaukee residents, particularly those in poverty, to applying for an absentee ballot in April was access to the internet and securing an image of their photo ID. To address this, the City will be promoting and utilizing Milwaukee Public Library branch staff (\$90,000 for both elections) for 3 weeks prior to each election to assist any potential absentee voters with applying, securing, and uploading images of their valid photo ID. **Total: \$90,000**
- **Racine:** The City will recruit and promote (\$1,000), train (\$3,000), and employ paid Voter Ambassadors (\$8,000) who will be provided with both PPE and

supplies (\$4,000) and set up at the City's community centers to assist voters with all aspects of absentee ballot request, including photo ID compliance. Due to the increase of absentee mailed requests the City of Racine will need an additional 2 full time staff members in the Clerk's Office in order to have a reasonable turn-around time for absentee requests (\$100,000). Total: **\$116,000**.

Total: \$635,700

2. Utilize Secure Drop-Boxes to Facilitate Return of Absentee Ballots

Our five communities all share a desire to expand voters' ability to easily return absentee ballots to the municipality without having to rely on the postal service, since, after April's election, many voters are (rightfully) apprehensive that putting their completed ballot in the mail does not guarantee it will be received and counted by the municipality by statutory deadlines. Voters also need to have confidence that they are returning their completed absentee ballots into secure containers that are not at risk of tampering. All five cities need resources to purchase additional secure drop-boxes and place them at key locations throughout their cities, including libraries, community centers, and other well-known places, to ensure that returning completed ballots is as secure and accessible to voters throughout our cities as possible.

- **Green Bay:** The City would like to add secure (security cameras \$15,000) ballot drop-boxes (approximately \$900 each) at a minimum of the transit center and two fire stations, but if funding were available would also install secure drop boxes at Green Bay's libraries, police community buildings, and potentially several other sites including major grocery stores, gas stations, University of Wisconsin Green Bay, and Northern Wisconsin Technical College, in addition to the one already in use at City Hall. **Total: \$50,000**
- **Kenosha:** The City currently has two drop-boxes that are checked throughout the day, and would like to install 4 additional internal security boxes at Kenosha libraries and the Kenosha Water Utility so that each side of town has easy access to ballot drop-boxes. **Total: \$40,000**
- **Madison:** The City would like to have one secure drop box for every 15,000 voters, or 12 drop boxes total (\$36,000). The City would also like to provide a potential absentee ballot witness at each drop box, utilizing social distancing and equipped with PPE (staff costs unknown): **Total: \$50,000**
- **Milwaukee:** The City would like to install secure 24-hour drop boxes at all 13 Milwaukee Public library branches, staffed with socially distanced volunteers to serve as witnesses. **Total: \$58,500**

- **Racine:** The City currently has one secured drop box for absentee ballots, and would like to have 3 additional drop boxes, each equipped with security cameras, to install at key locations around the City. **Total: \$18,000.**

Total: \$216,500

3. Deploy Additional Staff and/or Technology Improvements to Expedite & Improve Accuracy of Absentee Ballot Processing

The process of assembling and mailing absentee ballots is labor-intensive, slow, and subject to human error. Absentee ballot requests must be approved and entered into the statewide system, labels must be printed and applied to envelopes, ballots must be initialled, folded, and inserted into the envelope along with instructions. Ballots must be logged when received back from the voter. Undeliverable ballots must be reviewed, reissued or canceled. When voters make mistakes on ballots the requests to reissue must be completed. These tasks are time-consuming and utilizing existing clerk's office staff pulls them away from all of the other service requests, phone answering, and tasks handled by busy municipal clerks' offices.

The tremendous increase in absentee ballot requests in April was unprecedented, and municipal clerks and their staff were unprepared for the volume. They responded remarkably well - particularly since many of their staff were, by late March and early April, working remotely or, at a minimum, all needing to adhere to social distancing and masking precautions when working together in the same room - but all five municipalities need additional resources to accurately and swiftly process absentee ballot requests.

- **Green Bay:** The City needs 45 additional staff to process absentee ballot requests before the election, to open and verify envelopes on Election Day, and insert them into the tabulators. After the election, staff are needed to enter new voter registrations and assist with all election certification tasks (\$140,000 for staffing) The City would also like to purchase a ballot opener and ballot folder to expedite processing (\$5,000). **Total: \$145,000.**
- **Kenosha:** The City needs resources for absentee ballot processing, to staff and process early, in-person absentee requests, and to answer voters' questions (approximately \$100,000). Additional workers are also needed to canvass absentee ballots (approximately \$11,000) **Total: \$111,000**
- **Madison:** Based on data from April, the City estimates it will need additional staffing (\$110,000) for hourly election clerks for the fall elections, and will incur

additional overtime costs (\$100,000) for staff processing of absentee ballots and other election-related tasks. **Total: \$210,000**

- **Milwaukee:** Given its tremendous volume of absentee ballot requests and processing tasks which far exceeds that of the other municipalities, Milwaukee would like to completely automate and expedite the assembly and mailing of requested absentee ballots. The City would like to purchase a high-speed, duplex printer, a top-of-the-line folding machine, and a high quality folding and inserting machine. This would reduce staff costs and eliminate the use of absentee labels, by enabling the City to print directly onto inner and outer envelopes. This would also allow the City to have a small 2D barcode that the inserter machine would be able to scan to ensure that the outer envelope is for the same voter; increasing quality controls. This automation would enable the City to eliminate the assembly delay no matter the volume of daily absentee requests, allowing experienced election workers and previously trained election temporary employees to be re-deployed to early voting sites as supervisors and lead workers. **Total: \$145,000**
- **Racine:** To process absentee ballot requests in April, the City estimates that it will need seven additional full-time employees to process fall election requests. These employees will be needed full-time for one month prior to the August Election (approximately \$17,000) and seven weeks prior to the November election (approximately \$30,000). **Total: \$47,000**

Total: \$658,000

4. Expand In-Person Early Voting (Including Curbside Voting)

For a variety of reasons, many voters in our municipalities do not want to vote by mail and prefer to vote in-person. As a result of the coronavirus, far more voters are interested in early, in-person absentee voting (EIPAV) than we've seen in previous elections, wishing to avoid lines or crowds on Election Day. All five municipalities would like to have resources to accommodate these early, in-person voters. Expanding access to early, in-person voting also will lessen lines at polling places on Election Day and allow for proper social distancing and other pandemic precautions to be uniformly implemented.

Curbside and drive-thru voting have been very popular with residents of our municipalities, particularly for those with health concerns who can remain in the cars and have a virtually contact-less voting process. For example, Milwaukee previously operated in-person early voting for one week leading up to the April election at three sites and then transitioned to one site of drive-thru voting. 11,612 cast ballots through these options: 5,571 via in-person and 6,041 at drive-thru, and these numbers represent a 46% increase over April 2016 "early voting" totals. However, it is slow-moving and

labor-intensive. Additionally, particularly in the larger cities among us, it requires law enforcement and traffic control assistance to help manage traffic.

- **Green Bay:** The City would like to expand and establish at least three EIPAV sites in trusted locations, ideally on the east (potentially UWGB) and west sides (potentially NWTC or an Oneida Nation facility) of the City, as well as at City Hall. The City is planning to offer early voting starting two weeks before each election, with several weekdays available until 6:30pm and Saturdays 10am-4pm. They would like to staff these early voting sites with election inspectors who are bilingual and would like to increase the salary rate for these bilingual election inspectors to assist with recruitment and retention, as well as in recognition of their important role at these sites. The City also will need to print additional ballots, signage, and materials to have available at these early voting sites. **Total: \$35,000.**
- **Kenosha:** The City plans to have one early voting location, at City Hall, and plans to hold early voting two weeks before the August election, with no weekend or evening hours planned, and 4 weeks before the November election, with access until 7pm two days/week and Saturday voting availability the week before the election. If City Hall is still closed to the public, they will explore offering early drive thru voting on City Hall property. Resources are needed for staffing (approximately \$40,000), PPE (\$1,050), signage (\$200), laptops, printers, and purchase of a large tent (\$8,789) to utilize for drive thru early voting. Staff could see voters' ID, print their label, hand them their ballot, and then collect the completed envelope. This would also allow staff to help voters properly do certification and provide witness signatures if necessary. The City could do this for one full week before elections. **Total \$50,039.**
- **Madison:** The City would like to provide 18 in-person absentee voting locations for the two weeks leading up to the August election, and for the four weeks leading up to the November election. Their original plan was to offer in-person absentee voting at all nine library locations, the City Clerk's Office, a city garage, Edgewood College, two Madison College locations, and four UW-Madison locations. Due to weather uncertainties, they will need to purchase and utilize tents (\$100,000) for the curbside voting locations in order to protect the ballots, staff, and equipment from getting wet and will also need large feather flags to identify the curbside voting sites. (Additional staff costs covered by the earlier question re. Absentee ballot processing.) The City would also like to get carts (\$60,000) for our ExpressVote accessible ballot marking devices so we can use the ExpressVote for curbside voting to normalize the use of ExpressVote to help voters with disabilities feel less segregated during the voting process. **Total: \$160,000.**
- **Milwaukee:** The City would like to set up 3 in-person early voting locations for two weeks prior to the August election (\$150,000) and 15 in-person early voting

locations and 1 drive-thru location, potentially at a central location like Miller Park, for four weeks prior to the November election (\$450,000). (Establishing this many EIPAV sites requires a significant investment in IT equipment, an additional ballot printer, tents, signage, and traffic control assistance. Milwaukee would also like to offer evening and weekend early voting hours which would add additional costs for both August (\$30,000) and November (\$75,000). **Total: \$705,000.**

- **Racine:** The City would like to offer a total of 3 EIPAV satellite locations for one week prior to the August election, as well as offering in-person early voting - curbside, if City Hall is still closed to the public - at the Clerk's office for 2 weeks prior to the August election. For the November election, Racine would like to offer EIPAV at 4 satellite locations two weeks prior to the election and at the Clerk's office (again, potentially curbside) 6 weeks prior. The City would need to obtain PPE, tents, supplies and cover staff time and training (\$40,000). Racine would also like to have all satellite locations available for half-day voting the two Saturdays (\$17,000) and Sundays (\$17,000) prior to the November election, and the library and mall locations would be open until 8pm the week prior to the Election. Additional resources needed include one-time set-up fee per location (\$7,500), laptops and dymo printers (\$10,000), training (\$1,100), and signage (\$12,000.) As well, the City would like to host at least one drive-thru Voter Registration Day, where City Hall would be set up for residents to come get registered, curbside, and get their voting questions answered by Clerk's staff. Newly registered voters could also get assistance requesting absentee ballots for upcoming elections while they're there. (\$8,000) **Total: \$112,600**

Total: \$1,062,639.00

Recommendation I Total for All Strategies to Encourage and Increase Absentee Voting by Mail and Early, In-Person: \$2,572,839.00

Recommendation II: Dramatically Expand Voter & Community Education & Outreach, Particularly to Historically Disenfranchised Residents

All five municipalities expressed strong and clear needs for resources to conduct voter outreach and education to their communities, with a particular emphasis on reaching voters of color, low-income voters without reliable access to internet, voters with disabilities, and voters whose primary language is not English. This outreach is particularly necessary given the voter confusion that ensued in the lead-up to the April election, and voters' concerns and questions about voting during the COVID-19 pandemic. We understand that our communities of color do not necessarily trust the voting process, and that we need to work to earn that trust. We want to be transparent and open about what happens behind the scenes in elections, and what options are available for casting a ballot. We also want to make sure we are listening to groups that have historically been disenfranchised and groups that are facing obstacles with voting during this pandemic, and working with them to effectively respond to their concerns.

Voter outreach and education is also needed to encourage and explain new voter registration, and to encourage voters to verify and update their address or other voter registration information to do so prior to the Election. None of our communities have sufficient resources budgeted or available for the strategic, intentional, and creative outreach and education efforts that are needed in our communities over the summer and into the fall.

We all want our communities to have certainty about how the voting process works, trust in our election administration's accuracy, and current, accurate information on what options are available to vote safely in the midst of the pandemic. Significant resources are needed for all five municipalities to engage in robust and intentional voter education efforts to reduce confusion; encourage and facilitate new voter registration and registration updates; provide clear, accessible, and accurate information; address voters' understandable pandemic-related safety concerns; reassure voters of the security of our election administration; and, ultimately, reduce ballot errors and lost votes and enhance our residents' trust and confidence in our electoral process.

- **Green Bay:** Would like to reach voters and potential voters through a multi-prong strategy utilizing "every door direct mail," targeted mail, geo-fencing, billboards, radio, television, and streaming-service PSAs, digital advertising, and automated calls and texts (\$100,000 total). The City would also like to ensure that these efforts can be done in English, Spanish, Hmong, and Somali, since roughly 11% of households in the Green Bay area speak a language other than English. Ideally, the City would employ limited term communications staff or engage communications consultants (\$50,000) from August through the November election to design these communications and design and launch paid advertising on Facebook, Twitter, and Instagram, also in multiple languages. The City would also like to directly mail to residents who are believed to be eligible but not registered voters, approximately 20,000 residents. It would require both

considerable staff time to construct that list of residents and directly mail a professionally-designed piece (in multiple languages) to those voters. (\$50,000 total for staffing, design, printing, and postage). To assist new voters, the City would also like resources to help residents obtain required documents (i.e. birth certificates) which are needed to get a valid state ID needed for voting. These grant funds (\$15,000) would be distributed in partnership with key community organizations including churches, educational institutions, and organizations serving African immigrants, LatinX residents, and African Americans.

Total: \$215,000

- **Kenosha:** Would like to directly communicate to all Kenosha residents via professionally-designed targeted mail postcards that include information about the voter's polling location, how to register to vote, how to request an absentee ballot, and how to obtain additional information. The City would have these designed by a graphic designer, printed, and mailed (\$34,000). The City would also like resources for social media advertising, including on online media like Hulu, Spotify, and Pandora (\$10,000) and for targeted radio and print advertising (\$6,000) and large graphic posters (\$3,000) to display in low-income neighborhoods, on City buses, and at bus stations, and at libraries (\$5,000).
Total: \$58,000
- **Madison:** Would like to engage the City's media team to produce videos to introduce voters to the election process, voting options, and to explain the safety precautions taken at polls and early voting sites. These videos would then be shared in numerous ways, including through partner organizations and on the City's social media platforms. The City would also like to partner with community organizations and run ads on local Spanish-language radio, in the Spanish-language newspapers, on local hip hop radio stations, in African American-focused printed publications, and in online publications run by and for our communities of color (advertising total \$100,000). Additionally, the City has many poll workers who are from historically disenfranchised communities. The City would like to pay those poll workers (\$75,000) to conduct voter outreach and additional poll worker recruitment activities. **Total: \$175,000.**
- **Milwaukee:** Would like to partner with other City divisions to develop mailings and door hangers (\$10,000) that could accompany water bills, be distributed by the Department of Neighborhood Services, or hung on trash receptacles by sanitation staff. The City would also like to revamp current absentee voting instructions to be more visual, address issues specific to the pandemic such as securing a witness signature, prepare it in English and Spanish, and print 150,000 color copies (estimated total \$15,000). The Election Commission would also like to produce a short video (\$5,000) with visuals showing voters how to apply for an absentee ballot and how to correctly complete and return the ballot. Additionally, the Election Commission would like to hire a communications firm to prepare and implement a comprehensive voter outreach communications plan

(\$250,000). This communications effort would include numerous voter education ads and PSAs on radio, billboards, buses, with some using local celebrities like Milwaukee Bucks players. This communications effort would focus on appealing to a variety of communities within Milwaukee, including historically underrepresented communities such as LatinX and African Americans, and would include a specific focus on the re-enfranchisement of voters who are no longer on probation or parole for a felony. Additionally, this campaign would include an edgy but nonpartisan and tasteful communications campaign to harness the current protests' emphasis on inequity and ties that message to voting. The video, the ads, and the PSAs could all also be placed on social media, the Election Commission and City websites, and GOTV partner websites and social media. **Total: \$280,000**

- **Racine:** The City would like to retain a communications firm to design and implement a comprehensive voter outreach communications plan (\$80,000). This would include ads on Facebook, Instagram, and Snapchat. The City would also like to rent billboards in key parts of the City (\$5,000) to place messages in Spanish to reach Spanish-speaking voters. The City would also like to do targeted outreach aimed at City residents with criminal records to encourage them to see if they are not eligible to vote; this outreach will be accomplished with the production, editing, and sharing of a YouTube video (\$2,000) specifically on this topic shared on the City's website, social media channels, and through community partners. Racine would also like to purchase a Mobile Voting Precinct so the City can travel around the City to community centers and strategically chosen partner locations and enable people to vote in this accessible (ADA-compliant), secure, and completely portable polling booth on wheels, an investment that the City will be able to use for years to come. (Estimated cost \$250,000). **Total: \$337,000**

Recommendation II Total For All Strategies to Dramatically Expand Strategic Voter Education and Outreach Efforts, Particularly to Historically Disenfranchised Residents: \$1,065,000.00

Recommendation III: Launch Poll Worker Recruitment, Training, and Safety Efforts

The pandemic made conducting Election Day activities extremely challenging. Most poll workers in Wisconsin are retirees doing their civic duty to help facilitate the election. Given the increased risk for the elderly if exposed to COVID-19, many experienced poll workers opted out. Milwaukee had so many poll workers decline to serve that the City went from 180 polling locations to five polling locations. Green Bay, facing a similar exodus of poll workers, went down to two polling locations. Racine usually relies on nearly 190 poll workers for a spring election; only 25 of those experienced poll workers were under the age of 60.

As fears about the coronavirus increased in mid-late March and early April, poll workers in all five municipalities declined to work the election, leaving cities scrambling to quickly recruit enough bodies to keep polling locations open. All cities were appreciative of the last minute assignment of hundreds of Wisconsin National Guard members to assist with Election Day activities, and all of our cities re-assigned City staff from other departments to serve as poll workers and election officials and to assist with the myriad of tasks related to Election Day administration. The remainder of positions were staffed by high school students, college students, and members of the National Guard. Many of our poll workers had never worked an election before.

- **Green Bay:** The City needs to hire a total of 380 workers per election (total \$112,660). The City would like to pay poll workers more than they have previously received, to signify their importance in the process and to acknowledge the extra challenge it represents to serve as an election official during a pandemic. The City would like to increase poll worker salaries by 50% (additional \$56,330). All poll workers will be trained through the Wisconsin Elections Commission website and the City's own training manual (\$6,000). **Total: \$174,900**
- **Kenosha:** The City needs to hire 350 poll workers per election (\$100,000). They would like to offer hazard pay to increase pay to \$160/worker and \$220/chief inspectors (\$10,840). To aid in recruitment efforts, the City would like to hire a recruiter and liaison position for poll workers (\$35,000). **Total: \$145,840.**
- **Madison:** The City utilizes the election toolkit available through the MIT Technology Project to determine the staffing levels needed to ensure that voters will not have to wait in line for more than 15 minutes. In addition to the one Chief Inspector per polling location, Madison also has additional election officials who are certified as the Absentee Lead at each polling location. Madison estimates that if 75% of votes cast are absentee, the City will need 1,559 election officials at the polls in August. The City envisions a robust and strategic poll worker recruitment effort, focusing on people of color, high school students, and college students. The City would like to have resources for hazard pay for poll workers this fall at a rate comparable to what the U.S. Census is paying in the area

(\$369,788). The City has also found it challenging to convince facilities to host a polling location in the midst of a pandemic, and would like to provide each facility with a small amount of funds to compensate for their increased cleaning and sanitization costs (\$750/location, \$138,000 total). **Total: \$507,788**

- **Milwaukee:** The City plans to have 45 voting locations in August and to keep open as many of the normal 180 polling places as possible in November. August will require 3 chief inspectors per site and 20 election workers per site, for a total of 1200 election workers minimum and 150 chief inspectors. The City has a goal of recruiting 1,000 new election workers. The City would like to add an additional \$100 per worker in hazard pay to the poll workers' stipends of \$130 (\$460,000 additional for both elections) and \$100 hazard pay to chief inspector stipends of \$225 (\$87,750 additional for both elections). Additionally, the City of Milwaukee utilizes a Central Count of absentee ballots, which necessitates 15 chiefs and 200 election workers per election at Central Count (\$50,000/day for 2- days each election for a total of \$200,000). Total payroll for both elections will reach \$750,000 based upon these calculations. The City will launch a recruitment campaign for a new generation of election workers to sign up and be involved in their democracy, and hopes this effort can be included in the above request for resources for a marketing firm. Recruiting new and younger poll workers means that the Election Commission will need to innovate in election training. The Commission would like to produce polling place training videos (\$50,000) with live small-group, socially distanced discussions and Q&A sessions. These videos will augment existing training manuals. **Total: \$800,000**
- **Racine:** The City needs approximately 150 poll workers for August and 300 for November, in addition to 36 Chief Inspectors, and would like to pay all workers a \$100/election hazard pay (\$118,000 total payroll for both elections). City notes that its desire to have more early voting locations and hours is directly impacted by its ability to hire and train election officials. To that end, the City would like to launch a recruitment campaign that includes radio ads (\$1,000), ads on social media platforms (\$10,000), billboards in strategic City locations (\$5,000), and film videos for high school students in history/government classes (\$500). The City would also like to enlist a communication firm to: create a training video for election officials, develop an online quiz, detailed packets for election officials, and a PPE video filmed by a health professional about necessary COVID-19 precautions during all voting operations (\$22,000 total). Racine would also like to hire a liaison position to schedule, training and facilitate poll workers. (\$35,000) **Total: \$181,500.**

Recommendation III Total for All Strategies to Launch Poll Worker Recruitment, Training and Safety Efforts: \$1,810,028.00

Recommendation IV: Ensure Safe & Efficient Election Day Administration

It is no small task to mitigate risk of a lethal pandemic at all polling locations and throughout all required Election Day processing. Municipal clerks must ensure they have done everything possible to comply with public health guidelines and mitigate the risk of COVID-19 for all of the election officials, poll workers, observers, and voters. Our five municipalities are in need of numerous resources to both ensure seamless processing of voters on the upcoming Election Days, procure Personal Protective Equipment (PPE), disinfectant, and cleaning supplies to protect election officials and voters from the coronavirus, and to aid in processing of an expected high volume of absentee ballots. Additionally, as several of our municipalities move to add or expand drive-thru voting on Election Days, those expansions come with additional unbudgeted expenses for signage, tents, traffic control, publicity, and safety measures. All of our municipalities need resources to ensure that the remaining 2020 Election Days are administered seamlessly and safely.

- **Green Bay:** Green Bay would like to purchase 135 electronic poll books (\$2,100/each for a total of \$283,500) to reduce voter lines, facilitate Election Day Registrations and verification of photo ID. The City would also like a high speed tabulator (\$62,000) to count absentee ballots on Election Day, a ballot opener and ballot folder (\$5,000), and additional staff to process absentee ballots on Election Day (\$5,000). The City also needs masks, gloves, gowns, hair nets, face shields (\$15,000), cough/sneeze guards (\$43,000), and disinfectant supplies (\$3,000). **Total: \$426,500**
- **Kenosha:** The City would like to purchase automatic hand sanitizer dispensers for all polling locations (\$14,500) as well as PPE (gloves, masks, disinfectant, etc.) for all poll workers and voters (\$15,200). Kenosha would also like to be able to offer elderly residents and people with disabilities who wish to vote in person on Election Day two-way transportation, utilizing a local organization such as Care-A-Van (\$2,000). The City also needs resources for technology improvements to include a ballot opener, a ballot folder, 12 additional laptops and dymo printers, and high-speed scanner tabulators (\$172,000 total) to expedite election day processing and administration. **Total: \$203,700**
- **Madison:** The City needs hand sanitizer for all poll workers and voters, disinfectant spray, plexi-glass shields to allow poll workers to split the poll books, face shields for curbside election officials, and face masks for all poll workers and observers (\$20,000) as well as renting additional space to safely and accurately prepare all supplies and practice social distancing at the public test of election equipment (\$20,000) If the new voter registration form is not translated by the state into both Spanish and Hmong, Madison plans to translate the form (\$500). **Total: \$40,500**

- **Milwaukee:** The City will be purchasing 400 plexiglass barriers (\$55,000) for election workers at all polling location receiving and registration tables. Additionally, the Milwaukee Election Commission will need to acquire 400 face shields for workers not staffed behind plexiglass (\$4,000), gloves for all poll workers (\$3,000), masks on hand for election workers and members of the public (\$5,000), hand sanitizer (\$2,000) and disinfectant (\$2,000). Additionally, since Milwaukee also plans to offer curbside voting as an option at all polling places, updated, larger, more visible signage is necessary (\$5,000). **Total: \$76,000**
- **Racine:** Racine plans to issue all 36 wards its own PPE supply box which will each include masks, cleaning supplies, pens for each voter, gloves, hand sanitizer, safety vests, goggles, etc. (\$16,000). The City also needs large signs to direct and inform voters printed in English and Spanish (\$3,000). Additionally, the City would like to deploy a team of paid trained EDR Specialists for each polling location (\$10,000, including hourly pay, training expenses, and office supplies). As well, Racine would like iPads with cellular signal for each polling location to be able to easily verify voters' registration status and ward (\$16,000). The City would like to equip all wards with Badger Books (\$85,000); Racine began using electronic poll books in the February 2020 election and has found they dramatically increase and facilitate EDR, verification of voters' photo ID, expedite election processes, and reduce human error. **Total: \$130,000**

Recommendation IV Total for All Strategies to Ensure Safe & Efficient Election Day Administration: \$876,700.00

Conclusion

As Mayors in Wisconsin's five largest cities, we are committed to working collaboratively and innovatively to ensure that all of our residents can safely exercise their right to vote in 2020's remaining elections in the midst of the COVID-19 pandemic. The April 2020 election placed two of our most sacred duties in conflict: keeping our residents safe and administering free, fair, and inclusive elections. This Wisconsin Safe Voting Plan 2020 represents a remarkable and creative comprehensive plan, submitted collaboratively by all five of our cities. With sufficient resources, all five municipalities will swiftly, efficiently, and effectively implement the recommended strategies described in this plan, to ensure safe, fair, inclusive, secure, and professional elections in all of our communities this year.

From: Celestine Jeffreys
Sent: Wednesday, July 15, 2020 11:04 PM
To: Joanne Bungert
Subject: FW: Center for Tech & Civic Life Next Steps/Green Bay

JB,

Can you take a look and make sure this is kosher?!!

Money!!

Celestine Jeffreys
Chief of Staff, Mayor's Office
City of Green Bay

From: Tiana Epps-Johnson [mailto:tiana@techandcivillife.org]
Sent: Monday, July 13, 2020 6:31 PM
To: Celestine Jeffreys <Celestine.Jeffreys@greenbaywi.gov>
Cc: Selkove, Vicky <Vicky.Selkove@cityofracine.org>
Subject: Re: Center for Tech & Civic Life Next Steps/Green Bay

Hi Celestine,

So good to meet you. I'm really looking forward to working with you in the coming months! As Vicky shared, I'm reaching out to accomplish a few things:

- Share the WI Safe Voting Plan grant agreement for your review (attached)
- Collect point of contact information
- Schedule a kick-off meeting to take place next week

Grant Agreement

A draft grant agreement is attached for your review.

Actions needed:

1. Please review the agreement. Are there any requested revisions?
2. Are there any additional approvals required before you're able to accept the grant funds? If so, what are those steps? And what is the anticipated approval timeline?

Point of Contact Information

We want to be sure we direct our communications to the folks on your end best suited to respond.

Actions needed:

1. Please share the following:
 - a. Primary point of contact (Name, Email, Phone)
 - b. Clerk's office contact (Name, Email, Phone)
 - c. Mayor's office contact (Name, Email, Phone)
 - d. Finance contact (Name, Email, Phone)

Kick-off Meeting

We would like to schedule a one-hour kickoff meeting to take place next week. We'd like to use the meeting to:

- Meet each other's teams
- Share an overview of the technical assistance we have available to support implementation of your plans

March 10, 2021

Wisconsin Campaign and Elections Committee

I am the former, Brown County Clerk, of which the City of Green Bay is a jurisdiction. I served as County Clerk for 8 years and Deputy County Clerk for 14 years. Hence, I have 22 years' experience managing and conducting elections.

The reason I am here today is to describe what state statutes and election administration duties are charged to the county clerk, municipal clerks, and deputy clerks.

WI ss. 7.15(1) Supervise registration and elections. Each municipal clerk shall perform the following duties and any others which may be necessary to properly conduct elections or registration.

These duties and responsibilities include equipping polling places, maintenance and purchase of election equipment, prepare ballots and distribution, manage absentee ballot requests and delivery, prepare and post public notices, hire and train election officials, discharge election officials for improper conduct or willful neglect of duties; report fraud, irregularities, violations to the proper authorities, assign election inspectors to polling places, understand election laws and election administration rules, obtain required WEC election training and certification, and various other managerial functions and obligations.

Election security is of the utmost importance and clearly federal and state governments have worked the past 4 years to emphasize its significance by sending over \$400 million dollars to local governments to ensure the safety and legitimacy of elections in 2020. Clerks are charged with securing: the internet, electronic tabulation equipment, ballot and materials storage, and access to polling locations. Security is the single most important function because any potential breach can have a negative and direct effect on elections credibility and integrity.

The clerk, the jurisdiction's election official, is responsible and accountable for all facets of elections and performs these duties under oath of office. In the case of the City of Green Bay for the November 3, 2020 election, Kris Teske was the appointed city clerk, and served in this position for over 8 years.

I worked with Kris Teske throughout her tenure as city clerk and elections specialist. Kris conducted numerous elections efficiently, effectively and with accuracy. Kris was the chief election official in Wisconsin's third largest municipality. She is very fluent on election laws and is very particular in seeking guidance to questions, concerns, and related matters. Together, we accomplished many improvements in election processes, procedures, and purchasing election equipment. Her experience in managing elections in an ever-changing environment of election law, status of numerous lawsuits, and COVID concerns is commended.

In March of 2020, communication with the City Clerk's Office came to a halt. Under COVID, Mayor Eric Genrich, put city hall on lock down. Emails and phone calls to city offices were not answered. Access to city hall was prohibited. Suddenly, Brown County's largest municipality had no direct communication with the County Clerk's Office. I believe at this point the city clerk's election powers became compromised; and elections were taken over by the Mayor of Green Bay, Eric Genrich, and his chief of staff Celestine Jeffreys. Listed below are some news articles that support this claim.

1. March 20, 2020, Mayor Genrich along with several other mayors held a press conference expressing "concerns for safety of the public and their employees if an in-person election is held on April 7". This press conference followed the Democratic Party National Committee, and the Democratic Party of Wisconsin filed a suit in federal court to extend deadlines and suspend voter ID requirements due to the spread of the Virus."ⁱ
2. March 25, 2020 "the city of Green Bay and its clerk have filed a federal lawsuit against the Wisconsin Elections Commission and Evers administration seeking to delay the states April 7 election and transition it to an election conducted by mail".ⁱⁱ
3. April 5, 2020 "The mayors, who say they represent 1.3 million constituents in total, include Tom Barrett of Milwaukee, Erich Genrich of Green Bay, Lori Palmeri of Oshkosh, Tim Kabat of La Crosse, John Antaramian of Kenosha, Cory Mason of Racine, Tim Hanna of Appleton, Satya Rhodes-Conway of Madison, Karen Mischel of Viroqua and Kathy

00337

- Ehley of Wauwatosa" are asking "to postpone the state's primary and scrap in-person voting less than 12 hours before polls opened".ⁱⁱⁱ
4. April 9, 2020 "the city of Green Bay's Mayor, Eric Genrich intentionally caused chaos ahead of the April 7 election. Rather than to administer the election as safely and efficiently as possible, Genrich caused confusion and made it more difficult for people from his city to vote. His efforts through the election into chaos caused massive lines in the city of Green Bay to vote".^{iv}
 5. Sep. 24, 2020 "Green Bay receives half-a-million in grant money for improving election safety". "The Center for Tech and Civic Life non-profit is helping out cities across the county. About \$1.5 million in total is set aside for Green Bay, to buy equipment for polling locations and pay poll workers more. However, a series of federal lawsuits filed today in battleground states say the money is intended to use government employees to influence the count on the presidential election, by intentionally targeting Democratic strongholds to boost voter turnout in those areas only".^v

Following the spring primary, the mayor's office continued to control the elections at the frustration of the municipal clerk as indicated in synopsis of emails provided:

1. Kris Teske, March 16, 2020 "I'm not comfortable with the number of people coming into the Clerk's Office. I am going to setup a station for people to fill out their absentee request. Can I have everyone request a permanent absentee ballot, so they don't have to give photo ID?" To Genrich, Ellenbecker.
2. Kris Teske, May 8, 2020 "Do you know anything about hiring an elections specialist?" Vanessa Chavez response "Those would be questions for Celestine."
3. Kris Teske, June 19, 2020 "Yes, I have time on Monday." Ellenbecker response "Let's take each new issue/decision one at a time. I will try to be more supportive o your role as Clerk and decisions that you need to make. Let's move forward and not look behind."
4. Ellenbecker, July 8, 2020 "Sounds like there has been discussion about Hazard Pay, especially since we hove now received the \$1,093,400 grant." To Kris and Celestine
5. Kris Teske, July 9, 2020 "I haven't been in any discussions or emails as to what they are going to do with the money. I only know what has been on the news/in the media. I received an email this morning from the Mayor concerning using the old Circuit city building for early voting. I don't know anything about this or how it will be staffed. Are we going to use city staff that are certified in the system? The Clerk's Office doesn't have the staff to work at different locations when the Clerk's Office is open. Again, I feel I am being left out of the discussions and not listened to at the meetings. Also, it talked about electronic poll books and the faster tabulator. I was told by WEC we can't get electronic poll books this year and I don't think doing something like this on the biggest election would be good anyway. If we could get the faster tabulator that would be great, but I don't know if there are any left. I am worried about getting absentee ballots done on Election Day." To Ellenbecker.
6. Kris Teske, July 9, 2020 "I just attended the Ad Hoc meeting on Elections. I keep getting the run around on when I can purchase the DS450 if there are any available." "Did you see the Mayor's response to me concerning Satellite polling locations? You stated that I should let him, and Celestine know about the June 11th deadline. I feel he is mad but it's the law. Celestine said the attorneys will fight it out. If the decision is to go forward with additional sites, I would like it in writing for the file. I don't want anyone to think I didn't follow the law. In April, the WEC was fine with what we did because of the urgency. I don't know if you read my email asking who is going to staff these additional sites. I asked in the meeting if it was City staff and was told it could be. These people have to be certified in the WEC system to be able to run it. We don't have extra staff in the Clerk's office for this. I also stated that we can't just put two new people in a building and think they will be able to run it without questions." "I also asked when these people from the grant give us advisors who is going to be determining if their advice is legal or not. Every state has different laws. And this group is from Illinois. They already should have pointed out that additional in-person early voting sites can't happen because of the deadline has passed. I asked who are they going to be working with-Celestine? She said yes and the others but Kris you are the leader. None of this has been discussed with me. Celestine also stated the Ad Hoc Committee will be helping to make the decisions for the grant money. I thought this meeting was to assist the Clerk's Office. I don't know what our role is anymore. If you get a chance, please watch the meeting, and let me know your thoughts. I don't know what the answer is, and I don't think it pays to talk to the Mayor because he

- sides with Celestine, so I know this is what he wants. I just don't know where the Clerk's Office fits in anymore." To Ellenbecker.
7. Ellenbecker, July 14, 2020 "Kris, when we get to the acceptance of the Center for Tech & Civic Life Grant for \$1,093,400 and WEC for \$57,535.30 do you want me to send the microphone over to you first to discuss and explain or do you want me to send it to Celestine?" To Kris.
 8. Kris Teske, July 14, 2020 "Celestine would be the better choice. I have been reading things on Facebook about people complaining where the million is coming from. I think it might get political. Celestine also talked about having advisors from the organization giving the grant who will be "helping us" with the election and I don't know anything about that." To Ellenbecker.
 9. Kris Teske, July 14, 2020 "the city of Green Bay has been given money through some big grants. I have been given the go ahead to work with our procurement department manager to purchase a DS450. Please, please, please tell me you have one left to purchase." Response from Hoversten "The unit that I had allocated for you has been reallocated, after the decision from you not to purchase. I will put your name back on the list and hope for the best."
 10. Kris Teske, August 6, 2020 "We can purchase the DS450." To Winters, Ellenbecker, Jeffreys
 11. Kris Teske, August 28, 2020 "As you know I am very frustrated, along with the Clerk's Office. I don't know what to do anymore. I am trying to explain the process, but it isn't heard. I don't feel I can talk to the Mayor after the last meeting you, me, Celestine, and the Mayor had even though the door is always open. I don't understand how people who don't have the knowledge of the process can tell us how to manage the election. Ald. Dorf says the Clerk's Office is under attack?!?! Why?!?! You are my boss, so I am coming to you. If you can't help, please let me know who I should go to get this worked out." (to Ellenbecker)
 12. Priya Garg, US Digital Response, August 28, 2020 Subject: Sendgrid access for November elections. "We are moving forward to implement a very light tool that her and her team can use within the next week. We'll need Green Bay to sign up for "Essentials" pricing plan with Sendgrid. We'll be using Sendgrid to allow Kris and her team to send batch emails at scale, as opposed to having to manually send individual emails back and forth with election officers." To Mike Hronek.
 13. Kris Teske, August 31, 2020 "Here is a perfect example. I had everything setup (see attached email). Now they go to Celestine for the okay...what extra help? I told Ald. Gerlach what was needed for the privacy sleeves now Celestine is telling her something different and telling her that he will arrange the order and purchase." To Ellenbecker.
 14. Kris Teske, September 2, 2020 "As I think you are aware, I do not want to attend another ad hoc meeting. This committee isn't helping the Clerk's Office it's intimidating, micromanaging, and bullying behavior not assisting."
 15. Ellenbecker, September 4, 2020 "Hi mayor, Kris pulled together a list of additional equipment that we would like to request from CTCL." "Celestine requested need \$20,000 (for local groups) and another \$15,000 for absentee ballot collection and events. I think this money is not allocated in the current budget. It's a modest amount." To Genrich.
 16. Nathan Smith, CTCL, September 9, 2020 "Because Green Bay was one of the early recipients of funds under this program, we'll be able to expedite additional funds to get you the resources you need." To Teske, Ellenbecker, Jeffreys, Genrich.
 17. Kris Teske, September 10, 2020 "I have made known over and over we should not be hiring felons" (poll workers).
 18. Ellenbecker, September 21, 2020 "...Fox Ford grand Rapids, MI set up and approving two invoices for \$49,554 each (total of \$99,108). The payment schedule to be made tomorrow as the truck as the truck are expected on Wednesday?" To Nathan Wachtendonk.
 19. Ellenbecker, September 21, 2020 "Wanted to give you a heads up...Nathan Wachtendonk has done an amazing job searching and locating the Election trucks that are being covered by the election grant. They have been ordered, will be paid for tomorrow, and should be delivered Wednesday. These trucks will be extremely valuable during the election periods and are multi-purpose and can also be used by DPW and Parks." To Genrich, Jeffreys, Teske Wayte.
 20. May Whitney, CTCL, September 30, 2020 Subject: Dayna in Green Bay "She can help Kris with Central Count-making sure it's set up in a way that's safe and efficient for the Clerk's staff and observers. Essentially, she can take on any election task that you assign. And, if she's there, I imagine this will cut down on some of the back-and-forth with the phone calls and emails. I think I mentioned this before, but we have another person from Elections Group who is assisting Claire in Milwaukee. He moved there in September. So, all of this to say, having Dayna in Green Bay

isn't a new practice for the partners who are supporting the WI-5*. What do you think? Are y'all open to Dayna helping you in Green Bay?" To Celestine, Teske.

21. Rubenstein, National Vote at Home, Lead for Wisconsin, October 2, 2020 Subject: Ballot Curing "If you have a letter that goes out with rejected ballots, could you send that? (If not, I can create one." Celestine, could we meet next week with someone from the clerk's office to go over ballot curing and adding a call person? Sent to Celestine.
22. Celestine Jeffreys, October 3, 2020 Subject Ballot Curing "The grant mentors would like to meet with you to discuss, further, the ballot curing process. Please let them know when you're available." Sent to Kris.
23. Kris Teske, October 5, 2020 Subject: Ballot Curing "after Kim and I met with people from the grant team on curing we decided it wouldn't be beneficial to our office and they pretty much agreed that there wouldn't be any time savings. Our main issue was curing requests and they couldn't help us with that. The ballot curing has been going on since we sent out the ballot in September. We really don't have time to be working on a new process now that we have the ballots. (response to Ellenbecker, Celestine, Genrich, Chavez).
24. Kris Teske, October 6, 2020 "Since I requested the wrong amount last time can you please advise what I should do? We have about 380 poll workers (this was our goal) with applications coming in. Some of these people applying are quitting already and some regulars are backing out also with COVID being so bad. If I ask Celestine and the Mayor, they will say I am not making decisions and if I do it will be wrong."
25. Celestine Jeffreys, October 7, 2020 Subject: Signature Required. "Kris, the mayor asked that you sign this document once the Election Grant Team has chosen a messaging campaign. Here it is." To Teske.
26. Kris Teske, October 7, 2020 Subject: Signature Required. "I haven't been working with these people. I didn't purchase this Celestine did and should be the one signing this. She is the one working with them. I feel what this is about is me not signing the affidavit or the lawsuit, I'm not signing an affidavit for things Celestine did or purchased because she doesn't know election law. I will sign for what I purchased and why." To Ellenbecker.
27. Denise Gaumer Hutchinson, League of Women Voters, October 21, 2020 Subject: Helping with early absentee voting efforts "I am available and there are other LWV of Greater Green Bay also available if needed. The LWV is an organization committed to ensuring democracy for all citizens to participate in the election process. So. Please allow up to support the election process in Green Bay." Send to Kris, Celestine, Amaad.
28. Kris Teske, October 22, 2020 "I want you to be aware about the Clerk Staff that stated if they had the money, they would walk out the door now, another said I don't want to work here anymore, and the third is actively looking for a new job. All because the Mayors staff-even Melissa is bossing the Clerk Staff around. They call me crying or say they went home crying." To Ellenbecker.
29. Kris Teske, October 22, 2020 "So Jaime took the information up to Amaad...and Amaad is back tracking saying he only needs the chief inspectors' names to call and check in. Jaime started crying and they asked if she was overwhelmed...she is confused by what is going on. She feels they think she isn't doing a good job and I am trying to reassure her."
30. Kris Teske, October 22, 2020 "I am going to be on FMLA full time starting now. Since I don't know if I will need the full 12 weeks or not (I think I have used two so far) do you want me to bring the laptop, printer, and other things back?" To Ellenbecker.
31. Rivera, October 29, 2020 "No training for Central Count prior to election".

The County Clerk's Office was not able to confirm the shift of election control from the City Clerk's Office to the Mayor's Office until the week prior to the November 3 Election. My office was never notified that the City Clerk was off on FMLA either. I became concerned on October 28, 2020 upon receiving an email from a party unknown to me regarding the City's election tabulation equipment.

Michael Spitzer-Rubenstein Vote at Home, October 28, 2020 Subject: Question about Green Bay Central Count "Hi Sandy, I'm Michael Spitzer-Rubenstein, an advisor to the City of Green Bay through the National Vote at Home Institute. I'm helping the city set up Central Count for Tuesday. I heard from Kim there was some sort of issue with using DS200's at Central Count. I'm trying to get the full backstory to advise her and the mayor. Do you have a moment to speak this morning?"

This message alerted me that something was off. I didn't respond to him knowing that election security was at critical level. I made a call to WEC and they confirmed that Green Bay was working with consultants for the election. I expressed my concern that election laws might not be followed with an outside organization. They stated Rubenstein has helping Green Bay set up Central Count at an off-site location, KI Center. Likewise, they said that they reviewed with Green Bay the roles of outside organizations.

On November 3, 2020 Brown County Administrator, Corporation Counsel, and I visited the KI Center to observe the central count process. In previous Green Bay emails Rivera states that central count poll workers will be given their assignments on Election Day. No prior training would be given to these poll workers.

As a result, there were concerns with poll workers lack of training when we visited Central Count. First of all there was no consistency how the various tables were processing absentee ballots. Opened ballots were face up exposing votes and poll workers were observed reviewing how the ballots were marked. Black pens were available at worktables so there was no way to differentiate an elector's ballot marks from poll worker ballot marks. Poll workers were seen with cell phones on table tops which could easily violate election secrecy and security.

Election observers were located far away from poll workers, so they were no opportunity to see or hear the absentee ballot process. The video streaming provided was useless because images of processing were random and there was no audio provided. Green Bay provided access to the central count location but prevented observers from participating in the observation process. The physical location where they were placed does not meet state statutes. This was in direct violation of election laws. Observers had no opportunity to hear absentee electors' names, observe within legal distance to see ballots being processed, rejected or remade, or challenge questionable electors' ballots. Likewise, it was unclear to who was running central count. Although, Amaad Rivera, seemed to be the chief election inspector as he seemed to oversee ballot containers.

Within the central count area, there was an 8 ft. table was against a side wall. I observed Michael Spitzer-Rubenstein sitting at the table. There was a printer and laptop on the table, and he was constantly using his cell phone. He had a lanyard; however, I couldn't see what his role was nor did he identify himself when asked. Rubenstein moved freely within the central count processing area with access to all absentee ballot processing. He spoke with and advised poll workers on absentee ballot issues. He physically handled absentee ballots and had opportunity to review how absentee ballots were marked. I questioned Rivera about Rubenstein's role and I was told he was an observer. However, he had his own table within the central count area and unlimited access to workers and ballots unlike all other election observers.

Due to what I observed and not understanding who oversaw central count, I was terribly upset that a person from an outside organization had full access to the central count area and unlimited contact with absentee ballots. These constituted a violation of electronic election security of the physical location especially since Rubenstein, not city of Green Bay staff, was given 4 keys to central count several days preceding the election. Rubenstein is from Vote at Home, a different organization from that of the Center for Tech and Civic Life (CTCL) grant funds. When I got back to my office and looked up the organizations on the internet, I found that funding sources weren't public information. Following, I sent an email to Nathan Judnic, Staff Attorney, WEC, stating I felt the election process was tainted due to third party outside money and personal actively involved in running elections. Elections are a government function that should be protected from outside influences for free and fair elections.

I immediately sent an email to Nathan Judnic, attorney, Wisconsin Elections Commission.

"Nate, I have concerns about this person from an outside organization at the central count location for the City of Green Bay. I observed that he has a laptop, printer, and cell phone accessible within the central count facility. Likewise, we were told he is an observer for the outside organization that gave them a grant and his position is paid from by the even though he is from a different org. I observed him interacting with the poll workers and advising them on matters. I believe the central count location is tainted by the influence of a person working for an outside organization affecting the election. Please explain how grant money from a private outside organization and employee from a private outside organization does not violate election laws for free and fair elections?"

Following, is a response from Judnic to my email.

"Hi Sandy, thanks for the email. We've had several conversations with Green Bay leading up to today and are aware that they were going to be using consultants from some outside groups today. We've discussed the roles these individuals were going to be assigned and told them that while there is nothing that would prohibit the City from using these individuals, the inspectors and the absentee board of canvassers working the location are the individuals that are going to be making the decisions, not consultants. I have talked to Kim, the Deputy Clerk who was going to reach out to the central count folks and reinforce this guidance. I would certainly like to be made aware of issues or decisions that have been "tainted" at the central count. I'm not sure 100% what you mean. As far as grant money, etc., I'm again interested if there are issues or decision that

have been made that you think I should look into. I'm only really aware of the recent litigation related to grants given to municipalities which included Green Bay, Milwaukee, Madison and a couple of others, but I was under the impression that case was dismissed, and the US Supreme Court chose not to take it up prior to the election."

Security of elections includes the internet, tabulation equipment, access to ballots, access to poll workers and voting location, and direct influence over government election duties, responsibilities, and administration. My concern is that the city of Green Bay violated all these security matters. The City Clerk was in effect replaced by the mayor's office in running elections without certification, training, and understanding election laws. Likewise, they took funding from an outside organization and gave election access to 3rd party people who reside outside of Wisconsin and they were not city employees or under contract with the city of Green Bay. Celestine Jeffreys signed the contract with the Hyatt Regency for central count. In reading the agreement, Sun., Nov. 1, indicates:

"Number of keys to provide: 5 (4 to group and 1 for hotel to keep-Kristine Hall will hold for hotel). Deliver keys to: Michael Spitzer-Rubenstein" "Michael Spritzer-Rubenstein will be the on-site contact for the group. Tracy Hillesheim has his cell number should anyone have questions or needs to contact Michael."

Tues., Nov. 2, 2020 Security "DO NOT UNLOCK GRAND BALLROOM UNTIL MICHAEL SPITZER-RUBENSTEIN REQUESTS AND IS WITH SECURITY WHEN UNLOCKING THE GRAND BALLROOM DOOR." Misc. All "Amaad Rivera is the main contact for media on Tuesday."

In reviewing many of the emails received through open records request and shared with me, it's apparent that the election duties and responsibilities of the municipal clerk were thwarted by the Mayor's office during the 2020 election cycle. An appointed municipal clerk doesn't have the same independence and freedom in running elections as that of an elected official. The City of Green Bay Mayor's Office demonstrates how to effectively remove the city clerk from election responsibilities and confiscate the clerk duties protected under WI election laws. Hence, they brought people not certified in Wisconsin elections into the process, used untrained staff, and 3rd party outside organizations and staff that don't have knowledge of WI election laws and administration into the local election process. As the County Clerk, I questioned if election laws were followed, proper documentation of election paperwork exists, and the number of electronic or physical security breaches happened.

Election security is of the utmost importance for free and fair elections. Outside organizations have no place in government election affairs. Private election funds should not be infused into local government. We need to protect our clerks' election duties and responsibilities from being taken away by overzealous government officials that don't know election laws and administration. Likewise, third party funding and workers should not be co-mingled or involved in municipal elections. When it does, there is no transparency. It's really concerning when outside organizations don't release their finances and send people from outside Wisconsin that are not employed by the municipality or under municipal contract in any way to run municipal elections.

Wisconsin has elections laws to protect the electorate from outside influence in elections. However, I believe many of these protections were ignored or circumvented for the 2020 elections. Many of these came under the umbrella of "COVID"; however, we should learn from this that any issue can be applied to circumvent election laws.

Sandy Juno, Former Brown County Clerk

616 Dauphin St., Green Bay, WI 54301

junosandra@yahoo.com

*WI-5, refers to the cities of Green Bay, Kenosha, Madison, Milwaukee, and Racine CTCL coordinated election absentee ballot initiative.

ⁱ Wisconsin Examiner, Henry Redman, March 20, 2020

ⁱⁱ Wisconsin Public Radio, Laurel White, March 25, 2020

ⁱⁱⁱ ABC News, Kendall Karson, April 5, 2020

^{iv} WBAY, Brittany Schmidt, April 9, 2020

^ Midwest Communications, Casey Nelson, Sept. 24, 2020



CENTER FOR
TECH AND
CIVIC LIFE

May 28, 2020

City of Racine

Dear Mayor Mason,

I am pleased to inform you that the Center for Tech and Civic Life ("CTCL") has decided to award a grant to support the work of the City of Racine.

The following is a description of the grant:

AMOUNT OF GRANT: One hundred thousand US dollars (USD \$100,000).

PURPOSE: The grant funds must be used exclusively for the public purpose of planning safe and secure election administration in the City of Racine in 2020, and coordinating such planning with other cities in Wisconsin.

Before we transmit these funds, we ask that you sign this agreement promising to use the grant funds in compliance with United States tax laws. Specifically, by signing this letter you agree to the following:

1. The City of Racine is a U.S., state, or local government unit or political subdivision in the meaning of 26 USC 170(c)(1).
2. This grant shall be used *only* for the public purpose described above, and for no other purposes.
3. The City of Racine shall not use any part of this grant to give a grant to another organization unless CTCL agrees to the specific grant in writing, except as provided in paragraph 4.
4. The City of Racine shall grant ten thousand dollars (USD \$10,000) under this agreement to each of the cities of Green Bay, Kenosha, Madison, and Milwaukee solely for the public purpose of planning safe and secure election administration in those cities in 2020, and

00344

solely upon written confirmation from those entities that the funds shall be used for such purpose.

5. The City of Racine, and any cities granted funds under paragraph 4, shall produce, by June 15th, 2020, a plan for safe and secure election administration in each such city in 2020, including an assessment of election administration needs, budget estimates for such assessment, and an assessment of the impact of the plan on voters.
6. CTCL may discontinue, modify, withhold part of, or ask for the return all or part of the grant funds if it determines, in its sole judgment, that (a) any of the above conditions have not been met or (b) it must do so to comply with applicable laws or regulations.

Your acceptance of these agreements should be indicated below. Please have an authorized representative of The City of Racine sign below, and return a scanned copy of this letter to us by email at grants@techandciviclife.org.

On behalf of CTCL, I extend my best wishes in your work.

Sincerely,



Tiana Epps Johnson
Executive Director
Center for Tech and Civic Life

Accepted on behalf of the City of Racine:

By: _____

Title: _____

Date: _____



AGENDA OF THE COMMON COUNCIL

TUESDAY, JULY 21, 2020, 6:00 PM

Virtual Meeting

Public may also view at

www.youtube.com/CityOfGreenBay

A. Zoom Meeting Information.

- I. This item contains documents which provide call in information and instructions for the Zoom Meeting.

B. Roll Call.

C. Pledge of Allegiance.

D. Invocation.

- I. The invocation will be led by Jerry Bader, Pastor, Faith by the Bay Ministries, invited by Alder Brian Johnson, District 9.

E. Approval of Minutes.

- I. Approval of the minutes from the June 29, 2020 Common Council meeting.

F. Approval of the Agenda.

G. Report by the Mayor.

H. Announcements.

I. Appointments.

I. New Appointment

Zoning and Planning Board of Appeals

Tom Hoy, 1120 Cass Street, Green Bay, WI 54301

Term to expire: August 1, 2023

Re-appointment

Green Bay Sustainability Commission

John Arendt, 726 Sunrise Lane, Green Bay, WI 54301

Term to expire: August 1, 2023

J. Ordinances - Second Reading for Adoption.

1. Zoning Ordinance No. 09-20
An ordinance rezoning property located at 1341 Brosig Street from General Commercial (CI) District to Varied Density Residential (R3) District.
2. General Ordinance No. 19-20
An ordinance creating section 9.17, Green Bay Municipal Code, relating to responsible bidder criteria.
3. General Ordinance No. 21-20
An ordinance amending Section 29.208, Green Bay Municipal Code, relating to parking regulations.

K. Report of the Redevelopment Authority (July 14, 2020).

1. To approve a 2020 fee waiver for the parklet permit fee utilizing CARES Act funding or other available funding sources (communication from Ald. Johnson from June 29, 2020 Common Council meeting).
2. To approve a Hold Harmless Agreement with Downtown Green Bay, Inc. for a temporary outdoor dining space at 204, 206, 208, and 210 N. Washington Street (Tax Parcels 12-65, 12-66, 12-67, 12-68) and work with the Parking Division to ensure no loss of revenue.

L. Report of the Improvement & Services Committee (July 15, 2020).

1. To approve the request by Michael Krouth, 311 N. Henry Street, to refund \$470 in connection fees for mini-storm sewer connection.
2. To approve the request to amend and update the Stormwater Utility ordinance to include and explain the impact trees have on stormwater retention and drainage, and to provide a dollar credit to property owners who have trees planted or growing on their property in order to be consistent and fair with what the majority of the Common Council passed in November 2019. If the ordinance and Equivalent Residential Unit calculations are not adjusted appropriately, then Forestry expenses should no longer be paid for by Stormwater utility rates effective January 2021 (referred to staff at the April 29, 2020 Improvement and Services Committee meeting to modify existing ordinance to further define pervious area in the ordinance and report back to Committee) and to approve the draft General Ordinance No. 26-20. (Ald. Brunette)

3. To refer back to staff the request that Department of Public Works looks into the storm water sewer backups starting from East Shore Circle to California/East Shore Drive (referred to staff at the June 10, 2020 Improvement and Services Committee meeting). (Ald. Lefebvre)
4. To hold until the August 12, 2020 Improvement and Services Committee meeting the request for status update on plans to address chronic flooding in the vicinity of Main and East Mason Streets and Department of Public Works staff to report back to the Committee on feedback from designer on phasing the project (held at the December 10, 2019 Improvement and Services Committee meeting). (Ald. Nicholson)
5. To receive and place on file the request for (1) review of the Department of Public Works completion date expectations with possible action, and (2) notification to the Brown County Home Builders Association about the meeting as Department of Public Works staff will be meeting with Brown County Home Builders Association on December 12, 2019 (held at the April 8, 2020 Improvement and Services Committee meeting). (Ald. Nicholson)
6. To approve the request to amend Chapter 9, Subsection IV, Green Bay Municipal Code to address pavement assessments against residential properties located in mixed use zoning areas and to approve the draft General Ordinance No. 27-20. (Ald. Stevens)
7. To approve the request by Wisconsin Department of Transportation to enter into a Routine Maintenance and Operation Agreement for the Ray Nitschke Memorial (Main Street) Bridge for State Fiscal Year 2021 (July 1, 2020 – June 30, 2021).
8. To approve the request by Department of Public Works to award construction contract at a staff level and report the award at the next regular meeting of the Improvement and Services Committee for SEWERS 5-20 S. GRANDVIEW ROAD SANITARY SEWER.
9. To receive and place on file the actions taken by Department of Public Works

A. Granting of Licenses

1. Sidewalk Builder to Poblocki Paving Corp.
2. Underground Sprinkler System to ADC Maintenance LLC.

10. To receive and place on file the award of contract SOUTH BAY SHORE DIKE REINFORCEMENT to Vinton Construction in the amount of \$1,013,527.10.

M. Report of the Protection & Policy Committee (July 13, 2020 recessed and reconvened July 16, 2020).

1. To approve an application for a "Class B" Combination license for Tristas Lunchbox LLC at 1542 University with a licensed premises as "MAIN FLR, BAR, COOLERS, POOL ROOM, BACK OFFICE, TIKI BAR W/IN OUTDOOR PATIO, OUTDOOR PATIO," previously discussed at the June 8 Protection & Policy Committee meeting. (Previously licensed as Alisa Marie, LLC), with the approval of the proper authorities.

2. To approve a "Class A" Liquor and Class "A" Beer license for Mi Favorita Supermarket LLC at 1908 E. Mason St. with a licensed premises description of "coolers," with the approval of the proper authorities. (Previously licensed as Mi Favorita Supermarket).
3. To approve a "Class B" Combination License for Lil Jamaica LLC at 1332 S. Broadway with a licensed description as "bar area, 2 small closets, bathrooms, closet at back entrance, small attic, outdoor patio, side yard," with the approval of the proper authorities. (Previously licensed as Sunshine N Wallys Bar, Inc).
4. To approve a Class "B" Beer & "Class C" Wine license by Aldo's Pizza of Green Bay, LLC at 1247 Velp Ave. with a licensed premises as "Cooler, dining room," with the approval of the proper authorities. (Currently licensed as an individual Jean Cleary).
5. To approve a 2020-2021 renewal application for a "Class B" Combination License for Chip Stacks, Inc. at 416 Dousman St. with a change of agent and with the approval of proper authorities.
6. To approve a renewal application for the 2020-2021 license year for Strats, Inc. at 2850 Humboldt Rd. (Submitted June 29, 2020), with the approval of the proper authorities.
7. To approve the renewal applications for various liquor and/or beer licenses for the 2020-2021 license year with approval of the proper authorities (see attached).
8. To approve the release of the 2019-2020 "Class B" Combination licenses to the pool of available licenses due to no action taken for the 2020-2021 license year.
9. To approve a request by Hagemeister Park, Inc. at 325 N. Washington St. to amend their liquor license to include a sidewalk cafe permit adjacent to 325 N. Washington St.
10. To approve a request by Skogen's Foodliner, Inc. at 2430 University Ave. to amend their liquor license to include part of their parking lot for Click and Collect curbside pickup.
11. To approve a request by Skogen's Foodliner, Inc. at 2250 W. Mason St. to amend their liquor license to include part of their parking lot for Click and Collect curbside pickup.
12. To receive and place on file a request by Ald. Wery for an update with possible action on changes to the Ethics Ordinance/Policy that were requested in 2018, with explanation as to why it is taking so long while other newer programs, policies and ordinances are placed ahead of this item.
13. No recommendation on a request by Ald. Scannell to make a city ordinance requiring employees and the public in social situations to wear masks and practice social distancing.
14. To hold a request by Ald. Galvin that the city consider taking fluoride out of the treatment process for the city water to the next meeting of Protection and Policy committee for staff to provide available dates for a special meeting to address this item alone.
15. To approve General Ordinance 24-20, an ordinance amending Section 2.06(8), Green Bay Municipal Code, relating to reading of ordinances.

16. To hold a communication from Alder Dorff to research and create a fair housing ordinance for the City of Green Bay, previously discussed at the July 8, 2019 Protection & Policy meeting, to the next meeting of the Protection and Policy Committee to allow for more input from the public.
17. To approve General Ordinance number 22-20, repealing and recreating Section 6.39, Green Bay Municipal Code, relating to mobile food establishments.
18. To receive and place on file The Liquor Violation Report for July 13, 2020.
19. To receive and place on file an informational report regarding liquor licenses.

N. Report of the Protection & Policy Committee Granting Operator Licenses.

1. Report of the Protection & Policy Committee Granting Operator Licenses.

O. Report of the Plan Commission (July 13, 2020).

1. To receive and place on file a communication from Ald. Kathy Lefebvre (District 6) "To look at residential policy per storm water runoff; residences are experiencing rain water runoff from elevated houses because of floodplain building elevation requirements (FEMA)" (from May 26, 2020 Plan Commission meeting).
2. To refer to Planning Staff a communication from Ald. Barb Dorff (District 1) to "Estimate potential costs and benefits of proposed Grandview development" (from June 29, 2020 Council Meeting).
3. To receive and place on file a communication from Ald. Chris Wery (District 8) to "Request an update with any appropriate action on the property located at the corner of S. Ridge Road/Lombardi Avenue, owned by Kuehn Properties" (from July 2, 2020 email to the City Clerk).
4. To authorize a Conditional Use Permit (CUP) for self-service storage at 1929 Verlin Road, submitted by Curtis Klish, MCR Rentals, LLC, property owner (Ald. L. Gerlach, District 3).
 subje~~t~~ to:
 1. Compliance with all of the regulations of the Green Bay Municipal Code not covered under the Conditional Use Permit, including standard site plan review and approval.
 2. There shall be no expansion of the conditional use without Plan Commission and City Council Approval.
 Public hearing held 07/13/2020.
5. To amend Chapter 13-522(a)(7), Green Bay Zoning Code regarding temporary uses as presented by Planning Staff. Public hearing held 07/13/2020.

P. Report of the Finance Committee (July 14, 2020).

1. To approve the payoff of 2018 and 2019 Board of Commissioners of Public Lands state trust fund loans for a total of \$3,000,000 contingent on the approval of the next two items.
2. To approve refunding \$2,000,000 BCPL state trust fund loan for TID 22.

3. To approve refunding taxable 2010 General Obligation purpose bonds (BABs).
4. To approve the acceptance of the Center for Tech & Civic Life grant for \$1,093,400 as long as any clawback provision be brought back to the Common Council.
5. To approve the report out of the acceptance of the WEC CARES subgrant for \$57,535.30 with allowable uses to prevent, prepare for, and respond to coronavirus, domestically or internationally, for the 2020 Federal election cycle.
6. To receive and place on file the review of the City of Green Bay's 10-33 program inventory.
7. To approve the purchase of Type I ambulance for GBMFD for the sum of \$261,617 from Jefferson Fire & Safety, the lowest responsive, responsible bidder for RFQ #3266.
8. To approve the purchase of Mitel Phone system from CCCP off the SourceWell group purchasing cooperative contract contingent on the supporting documentation being included in the Council packet.
9. To approve Option #1 authorizing up to \$50,000 from our 2020 contingency fund and spreading the balance of the contract over 2021-2022 under the direction of the Procurement Manager to negotiate that agreement with the expectation of the Revaluation Assessment service to be completed by 1/1/22 for the 2023 Budget.
10. No recommendation on the request for approval of amendment to cell tower lease at Ted Fritsch Park, with with summary of change and amendment to be provided to Council.
11. No recommendation on the request for approval of amendment to cell tower lease at Fisk Park, with summary of change and amendment to be provided to Council.
12. To receive and place on file the request by Ald. Wery to offer a pay incentive/bonus for poll workers who have worked and will work this year during the Covid-19 situation, and to refer to HR / Personnel staff the request to adopt a policy for future hazard pay situations for research on hazard pay policies.
13. To receive and place on file the request by Ald. Wery for an update on the Zima v Schmitt lawsuit.

The Council may convene in closed session pursuant to Section 19.85(1)(g), Wis. Stats., for the purpose of conferring with legal counsel for the governmental body who is rendering oral or written advice concerning strategy to be adopted by the body with respect to litigation in which it is or is likely to become involved. The Council may thereafter reconvene in open session pursuant to Section 19.85(2), Wis. Stats., to report the results of the closed session and consider the balance of the agenda.

14. To receive and place on file the report of the Claims Committee.

The Council may convene in closed session pursuant to Section 19.85(1) (g), Wis. Stats., for the purpose of conferring with legal counsel for the governmental body who is rendering oral or written advice concerning strategy to be adopted by the body with respect to litigation in which it is or is likely to become involved. The Council may thereafter reconvene in open session pursuant to Section 19.85(2), Wis. Stats., to report the results of the closed session and consider the balance of the agenda.

Q. Report of the Park Committee (July 15, 2020).

1. To refer to staff to generate a cost estimate for the installation of surveillance equipment at Seymour Park and bring back to Park Committee for review.

2. To direct staff to research the feasibility of including funding to develop a park in the Bay Highlands area as part of the 5 year Capital Improvement Plan to be presented in the fall of 2020.
3. To hold until the next Park Committee the updates on the budget, cost estimates and phasing plan options for the beach project at Bay Beach Amusement Park.
4. To approve the request for the Wildlife Sanctuary to reinstate the on-site deer management program per the recommendations in the Bay Beach Wildlife Sanctuary On-Site White Tailed Deer Population Study.
5. To approve the updated 2020-2024 Green Bay Parks, Recreation and Forestry Open Space Plan.
6. To approve a resolution in support of the updated 2020-2024 Green Bay Parks, Recreation and Forestry Open Space Plan.
7.
 - A. To approve the purchase of one (1) Utility Vehicle for \$60,268 from Bobcat Plus Inc.
 - B. To approve the purchase of one (1) 26,000 GVW Cab & Chassis for \$69,970 from Truck Country of Iowa Inc.
8. To receive and place on file the staff update to the 2020 City of Green Bay Parks COVID-19 Reopening Plan as it relates to splash pads and wading pools. (INFORMATIONAL ONLY)

R. Ad Hoc Committee on Elections (July 9, 2020)

1. To approve the Wisconsin Safe Voting Plan (grant funded by the Center for Tech and Civic Life) and the recommendations contained therein.

S. Report of the Tax Incremental Districts Joint Review Committee (July 9, 2020).

1. To receive and place on file the Tax Incremental Districts annual reports.

T. Receive and Place on File.

1. Building Permit Report for June 2020.
2. Municipal Court Report for June 2020.

U. Committee of the Whole.

1. Consideration with possible action on "Resolution Providing for Face Coverings within the City of Green Bay," effective July 27, 2020.
2. Consideration with possible action on the "Resolution Extending the State of Emergency for the City of Green Bay COVID-19 Response."

V. Resolutions.

1. Resolution authorizing conditional use permit at 1929 Verlin Road.
2. An initial resolution authorizing the sale and issuance of not to exceed \$7,615,000 general obligation refunding bonds; and certain related details.
3. An initial resolution authorizing the sale and issuance of not to exceed \$2,085,000 taxable general obligation refunding bonds; and certain related details.
4. A resolution in support of the updated 2020-2024 Green Bay Parks, Recreation and Forestry Open Space Plan.
5. Resolution drawing final orders to contractors for July 21, 2020.
6. A Resolution extending the State of Emergency for the City of Green Bay COVID-19 response.
7. A Resolution providing for face coverings within the City of Green Bay.

W. Ordinances - First Reading.

1. General Ordinance number 22-20
An ordinance repealing and recreating Section 6.39, Green Bay Municipal Code, relating to mobile food establishments.
2. General Ordinance 24-20
An ordinance amending Section 2.06(8), Green Bay Municipal Code, relating to reading of ordinances.
3. General Ordinance No. 26-20
An ordinance amending Section 30.20, Green Bay Municipal Code, relating to Storm Water Utility.
4. General Ordinance No. 27-20
An ordinance amending Chapter 9, Subchapter IV, Green Bay Municipal Code, relating to Special Assessments.
5. General Ordinance No.28-20
An ordinance amending Section 13-522(a)(7), Green Bay Municipal Code relating to permitted temporary uses and structures.

X. Referral of Petitions & Communications.

Y. Adjournment.

- 1) SUPPLEMENTAL INFORMATION: The Video of this meeting, Agenda, Agenda Packet, and Minutes are available online at www.greenbaywi.gov/Meetings.
- 2) ACCESSIBILITY: Any person wishing to attend who requires special accommodation because of a disability, should contact the City Safety Manager at 920-448-3125 at least 48 hours before the scheduled meeting time so that arrangements can be made.

- 3) **QUORUM:** Please take notice that a majority or quorum of the Common Council will attend this committee meeting and will constitute a meeting of the Common Council for purposes of discussion and information gathering relative to this agenda.
- 4) **REPRESENTATION:** The party requesting the communication, or their representative, should be present at this meeting.



MINUTES OF THE COMMON COUNCIL

TUESDAY, JULY 21, 2020, 6:00 PM

Virtual Meeting

Public may also view at

www.youtube.com/CityOfGreenBay

A. ZOOM MEETING INFORMATION.

I. This item contains documents which provide call in information and instructions for the Zoom Meeting.

B. ROLL CALL.

Present: Brian Johnson, Chris Wery, Jesse Brunette, John VanderLeest, Mark Steuer, Veronica Corpus-Dax, Lynn Gerlach, Barbara Dorff, Bill Galvin, Craig Stevens, Randy Scannell, Kathy Lefebvre

C. PLEDGE OF ALLEGIANCE.

D. INVOCATION.

I. The invocation will be led by Jerry Bader, Pastor, Faith by the Bay Ministries, invited by Alder Brian Johnson, District 9.

The invocation was led by Jerry Bader, Pastor, Faith by the Bay Ministries, invited by Alder Brian Johnson, District 9.

E. APPROVAL OF MINUTES.

Moved by Ald. Barbara Dorff, seconded by Ald. Randy Scannell to approve. Motion carried.

I. Approval of the minutes from the June 29, 2020 Common Council meeting.

F. APPROVAL OF THE AGENDA.

Moved by Ald. Barbara Dorff, seconded by Ald. Lynn Gerlach to amend the agenda to take Committee of the Whole and Resolutions after Agenda Item I. Motion carried.

Moved by Ald. Randy Scannell, seconded by Ald. Barbara Dorff to approve as amended. Motion carried.

G. REPORT BY THE MAYOR.

H. ANNOUNCEMENTS.

I. APPOINTMENTS.

I. New Appointment

Zoning and Planning Board of Appeals

Tom Hoy, 1120 Cass Street, Green Bay, WI 54301

Term to expire: August 1, 2023

Re-appointment

Green Bay Sustainability Commission

John Arendt, 726 Sunrise Lane, Green Bay, WI 54301

Term to expire: August 1, 2023

Moved by Ald. Randy Scannell, seconded by Ald. Craig Stevens to approve the appointment. Motion carried.

Moved by Ald. Barbara Dorff, seconded by Ald. Veronica Corpus-Dax to approve the re-appointment. Motion carried.

J. ORDINANCES - SECOND READING FOR ADOPTION.

Moved by Ald. Barbara Dorff, seconded by Ald. Veronica Corpus-Dax to suspend the rules and take Ordinances 1 through 3 with a roll call vote. Motion carried.

Moved by Ald. Randy Scannell, seconded by Ald. Veronica Corpus-Dax to adopt Ordinances 1 through 3. Motion carried.

Yes- Barbara Dorff, Bill Galvin, Brian Johnson, Chris Wery, Craig Stevens, Jesse Brunette, John VanderLeest, Mark Steuer, Randy Scannell, Veronica Corpus-Dax, Kathy Lefebvre, Lynn Gerlach

1. Zoning Ordinance No. 09-20

An ordinance rezoning property located at 1341 Brosig Street from General Commercial (C1) District to Varied Density Residential (R3) District.

2. General Ordinance No. 19-20

An ordinance creating section 9.17, Green Bay Municipal Code, relating to responsible bidder criteria.

3. General Ordinance No. 21-20

An ordinance amending Section 29.208, Green Bay Municipal Code, relating to parking regulations.

K. REPORT OF THE REDEVELOPMENT AUTHORITY (JULY 14, 2020).

Moved by Ald. Brian Johnson, seconded by Ald. Randy Scannell to approve. Motion carried.

1. To approve a 2020 fee waiver for the parklet permit fee utilizing CARES Act funding or other available funding sources (communication from Ald. Johnson from June 29, 2020 Common Council meeting).

2. To approve a Hold Harmless Agreement with Downtown Green Bay, Inc. for a temporary outdoor dining space at 204, 206, 208, and 210 N. Washington Street (Tax Parcels 12-65, 12-66, 12-67, 12-68) and work with the Parking Division to ensure no loss of revenue.

L. REPORT OF THE IMPROVEMENT & SERVICES COMMITTEE (JULY 15, 2020).

Moved by Ald. Randy Scannell, seconded by Ald. Craig Stevens to approve. Motion carried.

Minutes of the Common Council

1. To approve the request by Michael Krouth, 311 N. Henry Street, to refund \$470 in connection fees for mini-storm sewer connection.

2. To approve the request to amend and update the Stormwater Utility ordinance to include and explain the impact trees have on stormwater retention and drainage, and to provide a dollar credit to property owners who have trees planted or growing on their property in order to be consistent and fair with what the majority of the Common Council passed in November 2019. If the ordinance and Equivalent Residential Unit calculations are not adjusted appropriately, then Forestry expenses should no longer be paid for by Stormwater utility rates effective January 2021 (referred to staff at the April 29, 2020 Improvement and Services Committee meeting to modify existing ordinance to further define pervious area in the ordinance and report back to Committee) and to approve the draft General Ordinance No. 26-20. (Ald. Brunette)

3. To refer back to staff the request that Department of Public Works looks into the storm water sewer backups starting from East Shore Circle to California/East Shore Drive (referred to staff at the June 10, 2020 Improvement and Services Committee meeting). (Ald. Lefebvre)

4. To hold until the August 12, 2020 Improvement and Services Committee meeting the request for status update on plans to address chronic flooding in the vicinity of Main and East Mason Streets and Department of Public Works staff to report back to the Committee on feedback from designer on phasing the project (held at the December 10, 2019 Improvement and Services Committee meeting). (Ald. Nicholson)

5. To receive and place on file the request for (1) review of the Department of Public Works completion date expectations with possible action, and (2) notification to the Brown County Home Builders Association about the meeting as Department of Public Works staff will be meeting with Brown County Home Builders Association on December 12, 2019 (held at the April 8, 2020 Improvement and Services Committee meeting). (Ald. Nicholson)

6. To approve the request to amend Chapter 9, Subsection IV, Green Bay Municipal Code to address pavement assessments against residential properties located in mixed use zoning areas and to approve the draft General Ordinance No. 27-20. (Ald. Stevens)

7. To approve the request by Wisconsin Department of Transportation to enter into a Routine Maintenance and Operation Agreement for the Ray Nitschke Memorial (Main Street) Bridge for State Fiscal Year 2021 (July 1, 2020 – June 30, 2021).

8. To approve the request by Department of Public Works to award construction contract at a staff level and report the award at the next regular meeting of the Improvement and Services Committee for SEWERS 5-20 S. GRANDVIEW ROAD SANITARY SEWER.

9. To receive and place on file the actions taken by Department of Public Works

A. Granting of Licenses

1. Sidewalk Builder to Poblocki Paving Corp.

2. Underground Sprinkler System to ADC Maintenance LLC.

10. To receive and place on file the award of contract SOUTH BAY SHORE DIKE REINFORCEMENT to Vinton Construction in the amount of \$1,013,527.10.

**M. REPORT OF THE PROTECTION & POLICY COMMITTEE (JULY 13, 2020
RECESSED AND RECONVENED JULY 16, 2020).**

Moved by Ald. Randy Scannell, seconded by Ald. Craig Stevens to approve with the exception of Items 12 and 13. Motion carried.

1. To approve an application for a "Class B" Combination license for Tristas Lunchbox LLC at 1542 University with a licensed premises as "MAIN FLR, BAR, COOLERS, POOL ROOM, BACK OFFICE, TIKI BAR W/IN OUTDOOR PATIO, OUTDOOR PATIO," previously discussed at the June 8 Protection & Policy Committee meeting. (Previously licensed as Alisa Marie, LLC), with the approval of the proper authorities.

2. To approve a "Class A" Liquor and Class "A" Beer license for Mi Favorita Supermarket LLC at 1908 E. Mason St. with a licensed premises description of "coolers," with the approval of the proper authorities. (Previously licensed as Mi Favorita Supermarket).

3. To approve a "Class B" Combination License for Lil Jamaica LLC at 1332 S. Broadway with a licensed description as "bar area, 2 small closets, bathrooms, closet at back entrance, small attic, outdoor patio, side yard," with the approval of the proper authorities. (Previously licensed as Sunshine N Wallys Bar, Inc).

4. To approve a Class "B" Beer & "Class C" Wine license by Aldo's Pizza of Green Bay, LLC at 1247 Velp Ave. with a licensed premises as "Cooler, dining room," with the approval of the proper authorities. (Currently licensed as an individual Jean Cleary).

5. To approve a 2020-2021 renewal application for a "Class B" Combination License for Chip Stacks, Inc. at 416 Dousman St. with a change of agent and with the approval of proper authorities.

6. To approve a renewal application for the 2020-2021 license year for Strats, Inc. at 2850 Humboldt Rd. (Submitted June 29, 2020), with the approval of the proper authorities.

7. To approve the renewal applications for various liquor and/or beer licenses for the 2020-2021 license year with approval of the proper authorities (see attached).

8. To approve the release of the 2019-2020 "Class B" Combination licenses to the pool of available licenses due to no action taken for the 2020-2021 license year.

9. To approve a request by Hagemeister Park, Inc. at 325 N. Washington St. to amend their liquor license to include a sidewalk cafe permit adjacent to 325 N. Washington St.

10. To approve a request by Skogen's Foodliner, Inc. at 2430 University Ave. to amend their liquor license to include part of their parking lot for Click and Collect curbside pickup.

11. To approve a request by Skogen's Foodliner, Inc. at 2250 W. Mason St. to amend their liquor license to include part of their parking lot for Click and Collect curbside pickup.

12. To receive and place on file a request by Ald. Wery for an update with possible action on changes to the Ethics Ordinance/Policy that were requested in 2018, with explanation as to why it is taking so long while other newer programs, policies and ordinances are placed ahead of this item.

Moved by Ald. Randy Scannell, seconded by Ald. Barbara Dorff to approve Item 12.

Moved by Ald. Chris Wery, seconded by Ald. Jesse Brunette to have the Law Department present the amended Ethics Ordinance/Policy to the Ethics Committee in September. Motion failed.

Yes- Brian Johnson, Chris Wery, Jesse Brunette, John VanderLeest, Mark Steuer, No- Barbara Dorff, Bill Galvin, Craig Stevens, Randy Scannell, Veronica Corpus-Dax, Kathy Lefebvre, Lynn Gerlach

A voice vote was taken on the original motion and motion carried.

13. No recommendation on a request by Ald. Scannell to make a city ordinance requiring employees and the public in social situations to wear masks and practice social distancing.

Moved by Ald. Brian Johnson, seconded by Ald. Barbara Dorff to receive and place on file Item 13. Motion carried.

14. To hold a request by Ald. Galvin that the city consider taking fluoride out of the treatment process for the city water to the next meeting of Protection and Policy committee for staff to provide available dates for a special meeting to address this item alone.

15. To approve General Ordinance 24-20, an ordinance amending Section 2.06(8), Green Bay Municipal Code, relating to reading of ordinances.

16. To hold a communication from Alder Dorff to research and create a fair housing ordinance for the City of Green Bay, previously discussed at the July 8, 2019 Protection & Policy meeting, to the next meeting of the Protection and Policy Committee to allow for more input from the public.

17. To approve General Ordinance number 22-20, repealing and recreating Section 6.39, Green Bay Municipal Code, relating to mobile food establishments.

18. To receive and place on file The Liquor Violation Report for July 13, 2020.

19. To receive and place on file an informational report regarding liquor licenses.

N. REPORT OF THE PROTECTION & POLICY COMMITTEE GRANTING OPERATOR LICENSES.

Moved by Ald. Randy Scannell, seconded by Ald. Veronica Corpus-Dax to approve. Motion carried.

I. Report of the Protection & Policy Committee Granting Operator Licenses.

O. REPORT OF THE PLAN COMMISSION (JULY 13, 2020).

Moved by Ald. Veronica Corpus-Dax, seconded by Ald. Craig Stevens to approve with the exception of Item 3. Motion carried.

1. To receive and place on file a communication from Ald. Kathy Lefebvre (District 6) "To look at residential policy per storm water runoff; residences are experiencing rain water runoff from elevated houses because of floodplain building elevation requirements (FEMA)" (from May 26, 2020 Plan Commission meeting).

2. To refer to Planning Staff a communication from Ald. Barb Dorff (District 1) to "Estimate potential costs and benefits of proposed Grandview development" (from June 29, 2020 Council Meeting).

3. To receive and place on file a communication from Ald. Chris Wery (District 8) to "Request an update with any appropriate action on the property located at the corner of S. Ridge Road/Lombardi Avenue, owned by Kuehn Properties" (from July 2, 2020 email to the City Clerk).

Moved by Ald. Randy Scannell, seconded by Ald. Veronica Corpus-Dax to approve Item 3. Motion carried.

4. To authorize a Conditional Use Permit (CUP) for self-service storage at 1929 Verlin Road, submitted by Curtis Klish, MCR Rentals, LLC, property owner (Ald. L. Gerlach, District 3). subject to:

1. Compliance with all of the regulations of the Green Bay Municipal Code not covered under the Conditional Use Permit, including standard site plan review and approval.
2. There shall be no expansion of the conditional use without Plan Commission and City Council Approval.

Public hearing held 07/13/2020.

5. To amend Chapter 13-522(a)(7), Green Bay Zoning Code regarding temporary uses as presented by Planning Staff. Public hearing held 07/13/2020.

P. REPORT OF THE FINANCE COMMITTEE (JULY 14, 2020).

Moved by Ald. Barbara Dorff, seconded by Ald. Randy Scannell to approve with the exception to Items 10 and 11. Motion carried.

1. To approve the payoff of 2018 and 2019 Board of Commissioners of Public Lands state trust fund loans for a total of \$3,000,000 contingent on the approval of the next two items.

2. To approve refunding \$2,000,000 BCPL state trust fund loan for TID 22.

3. To approve refunding taxable 2010 General Obligation purpose bonds (BABs).

4. To approve the acceptance of the Center for Tech & Civic Life grant for \$1,093,400 as long as any clawback provision be brought back to the Common Council.

5. To approve the report out of the acceptance of the WEC CARES subgrant for \$57,535.30 with allowable uses to prevent, prepare for, and respond to coronavirus, domestically or internationally, for the 2020 Federal election cycle.

6. To receive and place on file the review of the City of Green Bay's 10-33 program inventory.

7. To approve the purchase of Type I ambulance for GBMFD for the sum of \$261,617 from Jefferson Fire & Safety, the lowest responsive, responsible bidder for RFQ #3266.

8. To approve the purchase of Mitel Phone system from CCCP off the SourceWell group purchasing cooperative contract contingent on the supporting documentation being included in the Council packet.

9. To approve Option #1 authorizing up to \$50,000 from our 2020 contingency fund and spreading the balance of the contract over 2021-2022 under the direction of the Procurement Manager to negotiate that agreement with the expectation of the Revaluation Assessment service to be completed by 1/1/22 for the 2023 Budget.

10. No recommendation on the request for approval of amendment to cell tower lease at Ted Fritsch Park, with with summary of change and amendment to be provided to Council.

Moved by Ald. Randy Scannell, seconded by Ald. Brian Johnson to approve Item 10. Motion carried.

11. No recommendation on the request for approval of amendment to cell tower lease at Fisk Park, with summary of change and amendment to be provided to Council.

Moved by Ald. Brian Johnson, seconded by Ald. Veronica Corpus-Dax to approve Item 11. Motion carried.

12. To receive and place on file the request by Ald. Wery to offer a pay incentive/bonus for poll workers who have worked and will work this year during the Covid-19 situation, and to refer to HR / Personnel staff the request to adopt a policy for future hazard pay situations for research on hazard pay policies.

13. To receive and place on file the request by Ald. Wery for an update on the Zima v Schmitt lawsuit.

The Council may convene in closed session pursuant to Section 19.85(1)(g), Wis. Stats., for the purpose of conferring with legal counsel for the governmental body who is rendering oral or written advice concerning strategy to be adopted by the body with respect to litigation in which it is or is likely to become involved. The Council may thereafter reconvene in open session pursuant to Section 19.85(2), Wis. Stats., to report the results of the closed session and consider the balance of the agenda.

14. To receive and place on file the report of the Claims Committee.

The Council may convene in closed session pursuant to Section 19.85(1) (g), Wis. Stats., for the purpose of conferring with legal counsel for the governmental body who is rendering oral or written advice concerning strategy to be adopted by the body with respect to litigation in which it is or is likely to become involved. The Council may thereafter reconvene in open session pursuant to Section 19.85(2), Wis. Stats., to report the results of the closed session and consider the balance of the agenda.

Q. REPORT OF THE PARK COMMITTEE (JULY 15, 2020).

Moved by Ald. Barbara Dorff, seconded by Ald. Mark Steuer to approve. Motion carried.

1. To refer to staff to generate a cost estimate for the installation of surveillance equipment at Seymour Park and bring back to Park Committee for review.

2. To direct staff to research the feasibility of including funding to develop a park in the Bay Highlands area as part of the 5 year Capital Improvement Plan to be presented in the fall of 2020.

3. To hold until the next Park Committee the updates on the budget, cost estimates and phasing plan options for the beach project at Bay Beach Amusement Park.

4. To approve the request for the Wildlife Sanctuary to reinstate the on-site deer management program per the recommendations in the Bay Beach Wildlife Sanctuary On-Site White Tailed Deer Population Study.

5. To approve the updated 2020-2024 Green Bay Parks, Recreation and Forestry Open Space Plan.

6. To approve a resolution in support of the updated 2020-2024 Green Bay Parks, Recreation and Forestry Open Space Plan.

7.

- A. To approve the purchase of one (1) Utility Vehicle for \$60,268 from Bobcat Plus Inc.
- B. To approve the purchase of one (1) 26,000 GVW Cab & Chassis for \$69,970 from Truck Country of Iowa Inc.

8. To receive and place on file the staff update to the 2020 City of Green Bay Parks COVID-19 Reopening Plan as it relates to splash pads and wading pools. (INFORMATIONAL ONLY)

R. AD HOC COMMITTEE ON ELECTIONS (JULY 9, 2020)

Moved by Ald. Barbara Dorff, seconded by Ald. Randy Scannell to open the floor for discussion.
Motion carried.

Moved by Ald. Randy Scannell, seconded by Ald. Barbara Dorff to close the floor for discussion.
Motion carried.

Moved by Ald. Barbara Dorff, seconded by Ald. Randy Scannell to approve. Motion carried.

1. To approve the Wisconsin Safe Voting Plan (grant funded by the Center for Tech and Civic Life) and the recommendations contained therein.

S. REPORT OF THE TAX INCREMENTAL DISTRICTS JOINT REVIEW COMMITTEE (JULY 9, 2020).

Moved by Ald. Randy Scannell, seconded by Ald. Craig Stevens to approve. Motion carried.

1. To receive and place on file the Tax Incremental Districts annual reports.

T. RECEIVE AND PLACE ON FILE.

Moved by Ald. Randy Scannell, seconded by Ald. Barbara Dorff to approve. Motion carried.

1. Building Permit Report for June 2020.

2. Municipal Court Report for June 2020.

U. COMMITTEE OF THE WHOLE.

I. Consideration with possible action on "Resolution Providing for Face Coverings within the City of Green Bay," effective July 27, 2020.

Moved by Ald. Barbara Dorff, seconded by Ald. Randy Scannell to open the floor for discussion.
Motion carried.

Moved by Ald. Randy Scannell, seconded by Ald. Barbara Dorff to close the floor for discussion.
Motion carried.

Moved by Ald. Randy Scannell, seconded by Ald. Barbara Dorff to approve.

Moved by Ald. Randy Scannell, seconded by Ald. Barbara Dorff to amend Page 2(1)(b) to read (b) Indoor area accessible to the public means any interior area of any structure or premises licensed by the City of Green Bay or used in whole or in part as a place of resort, assemblage, lodging, trade, traffic, occupancy or other use by the public, to which the public customarily has access.
Motion carried.

Yes- Barbara Dorff, Bill Galvin, Brian Johnson, Craig Stevens, Jesse Brunette, Randy Scannell, Veronica Corpus-Dax, Kathy Lefebvre, Lynn Gerlach, No- Chris Wery, John VanderLeest, Mark Steuer

Moved by Ald. Brian Johnson, seconded by Ald. Jesse Brunette to strike Page 3 Section 1 (4) Enforcement and page 2 paragraph 3 but recognizes that penalties are necessary to ensure such compliance; now, therefore. Motion failed.

Yes-Brian Johnson, Chris Wery, Jesse Brunette, John VanderLeest, Mark Steuer, No-Barbara Dorff, Bill Galvin, Craig Stevens, Randy Scannell, Veronica Corpus-Dax, Kathy Lefebvre, Lynn Gerlach

Moved by Ald. Chris Wery, seconded by Ald. Jesse Brunette to refer to the Protection & Policy Committee. This motion was later rescinded.

Moved by Ald. Chris Wery, seconded by Ald. John VanderLeest to amend to add places of worship under exemptions. Motion carried.

Yes- Barbara Dorff, Brian Johnson, Chris Wery, Jesse Brunette, John VanderLeest, Mark Steuer, Randy Scannell No-Bill Galvin, Craig Stevens, Veronica Corpus-Dax, Kathy Lefebvre, Lynn Gerlach

Moved by Ald. Kathy Lefebvre seconded by Ald. Craig Stevens to amend on page 2 (1)(a) under definitions to read "and/or a face shield which covers the mouth and nose, covers the side of the face, and is secured on the head." Motion carried.

Yes- Barbara Dorff, Bill Galvin, Brian Johnson, Craig Stevens, Jesse Brunette, Randy Scannell, Veronica Corpus-Dax, Kathy Lefebvre, Lynn Gerlach, Chris Wery No-John VanderLeest, Mark Steuer

Moved by Ald. Brian Johnson, second by Ald. Jesse Brunette to strike 4b. Motion failed 6-6 with the Mayor breaking the tie with a no vote.

Yes- Brian Johnson, Chris Wery, Jesse Brunette, John VanderLeest, Mark Steuer, Veronica Corpus-Dax, No-Barbara Dorff, Bill Galvin, Craig Stevens, Randy Scannell, Kathy Lefebvre, Lynn Gerlach

Moved by Ald. Brian Johnson, seconded by Ald. Kathy Lefebvre to amend Section 2. to add after declaration of emergency "or if the County adopts a countywide mandate." Motion carried.

Yes-Barbara Dorff, Bill Galvin, Brian Johnson, Chris Wery, Jesse Brunette, John VanderLeest, Mark Steuer, Randy Scannell, Veronica Corpus-Dax, Kathy Lefebvre, Lynn Gerlach, No-Craig Stevens

Moved by Ald. Brian Johnson, seconded by Ald. Kathy Lefebvre to amend Section (4)(a) to remove "law enforcement may enforce trespassing laws and add "the individual shall be subject to a municipal forfeiture of \$10." Motion carried.

Yes-Bill Galvin, Brian Johnson, Chris Wery, Jesse Brunette, John VanderLeest, Mark Steuer, Randy Scannell, Veronica Corpus-Dax, Kathy Lefebvre, Lynn Gerlach, No-Barbara Dorff, Craig Stevens

Moved by Ald. Randy Scannell, seconded by Ald. Craig Stevens to approve as amended. Motion carried.

Yes-Barbara Dorff, Bill Galvin, Craig Stevens, Randy Scannell, Veronica Corpus-Dax, Kathy
Minutes of the Common Council

2. Consideration with possible action on the "Resolution Extending the State of Emergency for the City of Green Bay COVID-19 Response."

Moved by Ald. Randy Scannell, seconded by Ald. Barbara Dorff to approve. Motion carried.
Yes- Barbara Dorff, Bill Galvin, Craig Stevens, Mark Steuer, Randy Scannell, Veronica Corpus-Dax, Kathy Lefebvre, Lynn Gerlach, No- Brian Johnson, Chris Wery, Jesse Brunette, John VanderLeest

V. RESOLUTIONS.

Moved by Ald. Randy Scannell, seconded by Ald. Chris Wery to suspend the rules and adopt Resolutions 1 through 5 with one roll call vote. Motion carried.

Moved by Ald. Barbara Dorff, seconded by Ald. Veronica Corpus-Dax to adopt Resolutions 1 through 5. Motion carried.

Yes- Barbara Dorff, Bill Galvin, Brian Johnson, Chris Wery, Craig Stevens, Jesse Brunette, John VanderLeest, Mark Steuer, Randy Scannell, Veronica Corpus-Dax, Kathy Lefebvre, Lynn Gerlach

1. Resolution authorizing conditional use permit at 1929 Verlin Road.

2. An initial resolution authorizing the sale and issuance of not to exceed \$7,615,000 general obligation refunding bonds; and certain related details.

3. An initial resolution authorizing the sale and issuance of not to exceed \$2,085,000 taxable general obligation refunding bonds; and certain related details.

4. A resolution in support of the updated 2020-2024 Green Bay Parks, Recreation and Forestry Open Space Plan.

5. Resolution drawing final orders to contractors for July 21, 2020.

6. A Resolution extending the State of Emergency for the City of Green Bay COVID-19 response.

Moved by Ald. Barbara Dorff, seconded by Ald. Kathy Lefebvre to approve Resolution 6. Motion carried.

Yes- Barbara Dorff, Bill Galvin, Craig Stevens, Mark Steuer, Randy Scannell, Veronica Corpus-Dax, Kathy Lefebvre, Lynn Gerlach, No- Brian Johnson, Chris Wery, Jesse Brunette, John VanderLeest

7. A Resolution providing for face coverings within the City of Green Bay.

Moved by Ald. Randy Scannell, seconded by Ald. Barbara Dorff to approve as amended Resolution 7. Motion carried.

Yes- Barbara Dorff, Bill Galvin, Craig Stevens, Randy Scannell, Veronica Corpus-Dax, Kathy Lefebvre, Lynn Gerlach, No- Brian Johnson, Chris Wery, Jesse Brunette, John VanderLeest, Mark Steuer

W. ORDINANCES - FIRST READING.

Moved by Ald. Randy Scannell, seconded by Ald. Barbara Dorff to suspend the rules and advance Ordinances 1 through 5 to a second reading. Motion carried.

Moved by Ald. Randy Scannell, seconded by Ald. Barbara Dorff to advance Ordinances 1 through 5. Motion carried.

Yes- Barbara Dorff, Bill Galvin, Brian Johnson, Chris Wery, Craig Stevens, Jesse Brunette, John VanderLeest, Mark Steuer, Randy Scannell, Veronica Corpus-Dax, Kathy Lefebvre, Lynn Gerlach

1. General Ordinance number 22-20

An ordinance repealing and recreating Section 6.39, Green Bay Municipal Code, relating to mobile food establishments.

2. General Ordinance 24-20

An ordinance amending Section 2.06(8), Green Bay Municipal Code, relating to reading of ordinances.

3. General Ordinance No. 26-20

An ordinance amending Section 30.20, Green Bay Municipal Code, relating to Storm Water Utility.

4. General Ordinance No. 27-20

An ordinance amending Chapter 9, Subchapter IV, Green Bay Municipal Code, relating to Special Assessments.

5. General Ordinance No.28-20

An ordinance amending Section 13-522(a)(7), Green Bay Municipal Code relating to permitted temporary uses and structures.

X. REFERRAL OF PETITIONS & COMMUNICATIONS.

There were no petitions or communications.

Y. ADJOURNMENT.

Moved by Ald. Randy Scannell, seconded by Ald. Brian Johnson to adjourn at 12:51 a.m. Motion carried.

Kris A. Teske
Green Bay City Clerk

These minutes in their entirety, are available in the City Clerk's Office and on the City website at greenbaywi.gov

Johanna Juris

From: Wolfe, Meagan - ELECTIONS
<Meagan.Wolfe@wisconsin.gov>
Sent: Friday, August 28, 2020 11:07 AM
To: Kris Teske; Witzel-Behl, Maribeth; Coolidge, Tara;
Michelle Nelson
Cc: Woodall-Vogg, Claire; Rydecki, Richard H -
ELECTIONS; Magney, Reid - ELECTIONS
Subject: FW: Introduction to Vote At Home

Green Bay, Madison, Racine, and Kenosha-

Passing along a recommendation and resource from Milwaukee. Just wanted you to be aware in case you thought this might be a group you are interested in working with or learning more about. Claire in Milwaukee okayed me sending this along, and it sounds like you should reach out to Michael at michael@voteathome.org if you are interested in learning more.

Meagan

From: Woodall-Vogg, Claire <cwooda@milwaukee.gov>
Sent: Friday, August 28, 2020 10:55 AM
To: Magney, Reid - ELECTIONS <Reid.Magney@wisconsin.gov>; Wolfe, Meagan - ELECTIONS
<Meagan.Wolfe@wisconsin.gov>; Rydecki, Richard H - ELECTIONS <Richard.Rydecki@wisconsin.gov>
Cc: Michael Spitzer-Rubenstein <michael@voteathome.org>; Hillary Hall <hillary@voteathome.org>
Subject: Introduction to Vote At Home

Hi Meagan, Richard, and Reid,

I just wanted to reach out and connect you with Michael Spitzer-Rubenstein and Hillary Hall from the Vote at Home Institute in case you think other clerks or the WEC staff would find working with them useful.

I have been working with Hillary since early May. She was a tremendous resource in helping me decide to seek out a vendor to automate our absentee assembly process, as well as selecting drop boxes early on that were secure and met all of the requirements the WEC put forth last week.

I have been working with Michael to create inputs and outputs to help us determine staffing needs and staffing responsibilities at Central Count based on actual quantitative data. They have created a tool that is extremely useful in visualizing the time certain processes take. They will also be helping the Election Commission with our voter education communications around absentee voting and the messaging we will use. They have an extremely useful communications toolkit for clerks with zero resources to those that are hiring communication firms.

Hillary used to be a clerk in Colorado, so she also understands all of the other work we are doing and how precious and valuable time is.

All in all, they have essentially made my life much easier with the absolutely free technical assistance they are offering.

Claire

Claire Woodall-Vogg
Executive Director
414-286-3491
City of Milwaukee Election Commission



Update your voter registration, request an absentee ballot, or check your voting record at [MyVote](#)

The City of Milwaukee is subject to Wisconsin Statutes related to public records. Unless otherwise exempted from the public records law, senders and receivers of City of Milwaukee e-mail should presume that e-mail is subject to release upon request, and is subject to state records retention requirements. See City of Milwaukee full e-mail disclaimer at www.milwaukee.gov/email_disclaimer

Johanna Juris

From: Magney, Reid - ELECTIONS
<Reid.Magney@wisconsin.gov>
Sent: Wednesday, September 02, 2020 4:43 PM
To: Wolfe, Meagan - ELECTIONS; Rydecki, Richard H -
ELECTIONS
Subject: RE: Introduction to Vote At Home

We probably do. Just a question of when. Maybe later next week?

Sent from my U.S. Cellular® Smartphone

----- Original message -----

From: "Wolfe, Meagan - ELECTIONS" <Meagan.Wolfe@wisconsin.gov>
Date: 9/1/20 7:12 PM (GMT-06:00)
To: "Magney, Reid - ELECTIONS" <Reid.Magney@wisconsin.gov>, "Rydecki, Richard H - ELECTIONS"
<Richard.Rydecki@wisconsin.gov>
Subject: RE: Introduction to Vote At Home

Do we want to set up a meeting? Thoughts about who would be involved?

From: Michael Spitzer-Rubenstein <michael@voteathome.org>
Sent: Tuesday, September 1, 2020 5:09 PM
To: Wolfe, Meagan - ELECTIONS <Meagan.Wolfe@wisconsin.gov>; Magney, Reid - ELECTIONS
<Reid.Magney@wisconsin.gov>; Rydecki, Richard H - ELECTIONS <Richard.Rydecki@wisconsin.gov>
Cc: Hillary Hall <hillary@voteathome.org>
Subject: Re: Introduction to Vote At Home

Meagan, Reid, Richard,

I wanted to follow up: do you want to schedule a time to talk about how we can support the WEC and Wisconsin cities? We have some time at 9 AM either Thursday morning or Friday morning if that would work. Otherwise, our calendars are more open next week if that's better.

Thanks,
Michael

On Fri, Aug 28, 2020 at 1:42 PM Michael Spitzer-Rubenstein <michael@voteathome.org> wrote:

Thank you, Claire! Good to meet you, Meagan, Reid, and Richard.

We already have meetings scheduled about working with Madison, Green Bay, Kenosha, Racine, Eau Claire, Wauwatosa but are certainly interested in other jurisdictions, as well.

We're working on a Wisconsin-specific version of our [communications toolkit](#) with language about voter ID and absentee witness requirements informed by behavioral science. It would be great to do Zoom trainings for clerks about communications/voter education, operational planning, and could also facilitate sessions on more technical issues like curing absentee ballots, signature verification, etc.

Do you have any time to talk next week about how we can support your work? Right now, it looks like Monday morning, Wednesday, or Friday morning are probably best for us but we can work around your schedules.
Michael

Michael Spitzer-Rubenstein

State Lead for Wisconsin (Leadership Now Fellow)

National Vote at Home Institute

(310) 980-2872

he/him

VOTE HOME

From: Woodall-Vogg, Claire <cwooda@milwaukee.gov>

Date: Friday, August 28, 2020 at 12:01 PM

To: Wolfe, Meagan - ELECTIONS <Meagan.Wolfe@wisconsin.gov>, Magney, Reid - ELECTIONS <Reid.Magney@wisconsin.gov>, Rydecki, Richard H - ELECTIONS <Richard.Rydecki@wisconsin.gov>

Cc: Michael Spitzer-Rubenstein <michael@voteathome.org>, Hillary Hall <hillary@voteathome.org>

Subject: RE: Introduction to Vote At Home

Absolutely! They should reach out to Michael and I am happy to provide a reference. They are extremely respectful of time, are not "selling" anything, and have incredible resources.

From: Wolfe, Meagan - ELECTIONS <Meagan.Wolfe@wisconsin.gov>

Sent: Friday, August 28, 2020 11:01 AM

To: Woodall-Vogg, Claire <cwooda@milwaukee.gov>; Magney, Reid - ELECTIONS <Reid.Magney@wisconsin.gov>; Rydecki, Richard H - ELECTIONS <Richard.Rydecki@wisconsin.gov>

Cc: Michael Spitzer-Rubenstein <michael@voteathome.org>; Hillary Hall <hillary@voteathome.org>

Subject: RE: Introduction to Vote At Home

Thank you for sending along Claire. Would we be able to send your email to other large to medium-large jurisdictions to let them know about the resource and your experience? If other jurisdictions are interested, who should they reach out to at Vote at Home?

Meagan

From: Woodall-Vogg, Claire <cwooda@milwaukee.gov>

Sent: Friday, August 28, 2020 10:55 AM

To: Magney, Reid - ELECTIONS <Reid.Magney@wisconsin.gov>; Wolfe, Meagan - ELECTIONS <Meagan.Wolfe@wisconsin.gov>; Rydecki, Richard H - ELECTIONS <Richard.Rydecki@wisconsin.gov>

Cc: Michael Spitzer-Rubenstein <michael@voteathome.org>; Hillary Hall <hillary@voteathome.org>

Subject: Introduction to Vote At Home

Hi Meagan, Richard, and Reid,

I just wanted to reach out and connect you with Michael Spitzer-Rubenstein and Hillary Hall from the Vote at Home Institute in case you think other clerks or the WEC staff would find working with them useful.

I have been working with Hillary since early May. She was a tremendous resource in helping me decide to seek out a vendor to automate our absentee assembly process, as well as selecting drop boxes early on that were secure and met all of the requirements the WEC put forth last week.

I have been working with Michael to create inputs and outputs to help us determine staffing needs and staffing responsibilities at Central Count based on actual quantitative data. They have created a tool that is extremely useful in visualizing the time certain processes take. They will also be helping the Election Commission with our voter education communications around absentee voting and the messaging we will use. They have an extremely useful communications toolkit for clerks with zero resources to those that are hiring communication firms.

Hillary used to be a clerk in Colorado, so she also understands all of the other work we are doing and how precious and valuable time is.

All in all, they have essentially made my life much easier with the absolutely free technical assistance they are offering.

Claire

Claire Woodall-Vogg

Executive Director

414-286-3491

City of Milwaukee Election Commission



Update your voter registration, request an absentee ballot, or check your voting record at [MyVote](#)

The City of Milwaukee is subject to Wisconsin Statutes related to public records. Unless otherwise exempted from the public records law, senders and receivers of City of Milwaukee e-mail should presume that e-mail is subject to release upon request, and is subject to state records retention requirements. See City of Milwaukee full e-mail disclaimer at www.milwaukee.gov/email_disclaimer

Michael Spitzer-Rubenstein

State Lead for Wisconsin (Leadership Now Fellow)

National Vote at Home Institute

(310) 980-2872

he/him



Johanna Juris

From: Celestine Jeffreys
<Cestine.Jeffreys@greenbaywi.gov>
Sent: Tuesday, October 06, 2020 8:51 PM
To: Rydecki, Richard H - ELECTIONS
Subject: RE: student voters and drop box closing time

Thank you, Richard. I appreciate the answers.

Celestine Jeffreys
Chief of Staff, Mayor's Office
City of Green Bay

From: Rydecki, Richard H - ELECTIONS <Richard.Rydecki@wisconsin.gov>
Sent: Tuesday, October 6, 2020 1:44 PM
To: Celestine Jeffreys <Cestine.Jeffreys@greenbaywi.gov>
Subject: RE: student voters and drop box closing time

Hi Celestine,

Sorry about the delay in getting back to you regarding these issues. Here are my thoughts:

1. Online voter registration is only available for voter who have a current and valid product from Wisconsin DMV. The data match between the voter registration data and the DMV data is required by law for online registration. Voters who do not have one of these products are not eligible to register online. It would take a legislative change to open that system up to voters without a product from the WI DMV.
2. We think it is reasonable to establish an administrative timeline for final pickups at drop boxes. Statute states that ballots must be returned in time to be delivered to the polling place by 8:00 PM on election day. If a drop box has had their final pickup we think that signage indicating it is closed is essential so that voters understand their remaining options for returning their ballot. I have previously provided some guidance to the clerk's office on this issue and I have attached that email for your reference.

Let me know if you have any further questions and I will be happy to assist.

Best,

Richard Rydecki
Assistant Administrator
Wisconsin Elections Commission
212 East Washington Avenue, Third Floor
Madison, WI 53703
Phone: (608)261-2015

From: Celestine Jeffreys <Cestine.Jeffreys@greenbaywi.gov>
Sent: Friday, October 02, 2020 11:30 AM

To: Rydecki, Richard H - ELECTIONS <Richard.Rydecki@wisconsin.gov>

Subject: student voters and drop box closing time

Richard,

The clerk's office is swamped, and I'm very happy you're able to answer our questions. It saves a step.

First, if a UW Green Bay student voter has a valid student ID but doesn't have an ID with the voting address, what can they upload in My vote to register online? Can they register online with a UW ID and another document?

Then, are the drop boxes supposed to close at 7 pm on Election Day?

Thanks!!

Celestine Jeffreys

Chief of Staff, Mayor's Office

City of Green Bay

Johanna Juris

From: Eric Genrich <Eric.Genrich@greenbaywi.gov>
Sent: Saturday, October 24, 2020 12:34 PM
To: Rydecki, Richard H - ELECTIONS
Subject: Re: WEC Contact Today?
Attachments: image002.jpg

Perfect. Thank you!

Sent from my iPhone

On Oct 24, 2020, at 12:14 PM, Rydecki, Richard H - ELECTIONS <Richard.Rydecki@wisconsin.gov> wrote:

Mayor Genrich,
The active voter count for the City of Green Bay as of a minute ago is: 55,961. We post updated absentee statistics each morning on this page of our website, including the same municipal breakdown I sent you for Green Bay this morning: <https://elections.wi.gov/elections-voting/statistics>. You have to scroll down to the Absentee Voting Statistics section and open the report for the particular day you are looking for.
I entered all of the drop box and in-person absentee information for the city and confirmed it is now live on MyVote. Feel free to review it and let me know if we need any edits.

Best,

Richard Rydecki

Assistant Administrator
Wisconsin Elections Commission
212 East Washington Avenue, Third Floor
Madison, WI 53703
Phone: (608)261-2015

From: Eric Genrich <Eric.Genrich@greenbaywi.gov>
Sent: Saturday, October 24, 2020 11:34 AM
To: Rydecki, Richard H - ELECTIONS <Richard.Rydecki@wisconsin.gov>
Subject: Re: WEC Contact Today?

This is great, Richard. Do you also track the registered voter number? Is there any way I could get this auto-generated for me at the end of every day, or could I just consult the WEC website? Also trying to lighten the load for clerk staff.

From: Rydecki, Richard H - ELECTIONS <Richard.Rydecki@wisconsin.gov>
Sent: Saturday, October 24, 2020 10:08 AM
To: Eric Genrich <Eric.Genrich@greenbaywi.gov>
Subject: RE: WEC Contact Today?

Mayor Genrich,
Here are the aggregate absentee numbers we have for the City of Green Bay as of this morning:

Municipality	Requests	Ballots issued	Ballots returned	In-person absentee ballots issued
CITY OF GREEN BAY - BROWN COUNTY	28658	28615	21558	2505

Please note the in-person absentee totals are also accounted for in the other columns, and are a breakout from those totals. Let me know if you have any questions or need anything else. I will let you know when I have the other data entered for you and you can test it out.

Best,

Richard Rydecki

Assistant Administrator
Wisconsin Elections Commission
212 East Washington Avenue, Third Floor
Madison, WI 53703
Phone: (608)261-2015

From: Eric Genrich <Eric.Genrich@greenbaywi.gov>

Sent: Saturday, October 24, 2020 9:56 AM

To: Rydecki, Richard H - ELECTIONS <Richard.Rydecki@wisconsin.gov>

Subject: Re: WEC Contact Today?

And if you could just get me that aggregate info on absentee voting I can use that for a social media post.

Really appreciate all your support.

Eric

From: Eric Genrich <Eric.Genrich@greenbaywi.gov>

Sent: Saturday, October 24, 2020 9:54 AM

To: Rydecki, Richard H - ELECTIONS <Richard.Rydecki@wisconsin.gov>

Cc: Kim Wayte <Kim.Wayte@greenbaywi.gov>; Amaad Rivera <Amaad.Rivera@greenbaywi.gov>

Subject: Re: WEC Contact Today?

Here's the in-person absentee info: <https://greenbaywi.gov/655/Election-Information>

And drop box locations:

- Frontage Road across from Festival Foods Green Bay West (2250 West Mason Street)
- Former Sears Building, parking lot of Green Bay Plaza (803 S. Military Ave.)
- McAuliffe Park (405 Kristy Lee Court)
- Guns Road across from Green Bay EA building (2256 W Main Street)
- One in front and one behind Green Bay City Hall (100 N Jefferson Street)

Thanks again, Richard!

Eric

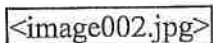

Election Information | Green Bay, WI

Early In-Person Absentee Voting at City Hall. City Hall, 100 N. Jefferson First Floor, will be host early in-person absentee voting for the November 2020 Election, beginning 10/20/20 and ending 10/31/20. This is for City of Green Bay

Residents only. Tuesday, October 20, 8:00 AM to 4:30 PM; Wednesday, October 21, 8:00 AM to 6:30 PM

greenbaywi.gov

From: Rydecki, Richard H - ELECTIONS <Richard.Rydecki@wisconsin.gov>

Sent: Saturday, October 24, 2020 9:41 AM

To: Eric Genrich <Eric.Genrich@greenbaywi.gov>

Cc: Kim Wayte <Kim.Wayte@greenbaywi.gov>

Subject: RE: WEC Contact Today?

Mayor Genrich,

We have staff available today if you need assistance. By reports, I assume these are reports out of WisVote so I can have a specialist call Kim to discuss those. Let me know a good number where we can reach Kim as we have WisVote staff scheduled to start at 10 AM today. As for your MyVote concerns, I can discuss those with you and I am available now if you would like to give me a call (608-261-2015). If there is a time that works better for you let me know and we can schedule that.

Best,

Richard Rydecki

Assistant Administrator

Wisconsin Elections Commission

212 East Washington Avenue, Third Floor

Madison, WI 53703

Phone: (608)261-2015

From: Eric Genrich <Eric.Genrich@greenbaywi.gov>

Sent: Saturday, October 24, 2020 9:23 AM

To: Rydecki, Richard H - ELECTIONS <Richard.Rydecki@wisconsin.gov>

Cc: Kim Wayte <Kim.Wayte@greenbaywi.gov>

Subject: WEC Contact Today? .

Hi Richard -

Deputy Clerk Wayte had a couple questions about WEC reports, and I have a question about GB-specific information that isn't displaying in MyVote. Is there anyone we can speak to today?

Thanks so much,

Eric

Johanna Juris

From: Celestine Jeffreys
<Celestine.Jeffreys@greenbaywi.gov>
Sent: Wednesday, October 28, 2020 11:22 AM
To: Rydecki, Richard H - ELECTIONS
Subject: RE: Urgent question

Perfect, thanks!!



Celestine Jeffreys

Chief of Staff
Office of the Mayor
920.448.3006

It's All Here!

From: Rydecki, Richard H - ELECTIONS <Richard.Rydecki@wisconsin.gov>
Sent: Wednesday, October 28, 2020 11:18 AM
To: Celestine Jeffreys <Celestine.Jeffreys@greenbaywi.gov>
Subject: RE: Urgent question

Celestine,

There is no problem with using multiple machine types at central count. Both of the machines you listed are certified for use in Wisconsin elections. You may have to ask the vendor about how you will need to aggregate and report results from the different memory sticks. The DS450 does not have any results transmission features, so results from those machines will have to be hand delivered to the county.

Let me know if this does not make sense or if you have any additional questions.

Best,

Richard Rydecki
Assistant Administrator
Wisconsin Elections Commission
212 East Washington Avenue, Third Floor
Madison, WI 53703
Phone: (608)261-2015

From: Celestine Jeffreys <Celestine.Jeffreys@greenbaywi.gov>
Sent: Wednesday, October 28, 2020 8:36 AM
To: Rydecki, Richard H - ELECTIONS <Richard.Rydecki@wisconsin.gov>

Subject: Urgent question

Importance: High

Good morning, Richard!

I'm sure you receive many urgent emails.

We have a question about using different ES&S machines. We've obtained one DS450 for central count. We lease DS200s from Brown County and have given those assigned to us back to the county for their use.

Can we use both styles of machines, simultaneously, at central count? Is there something in the law that prevents us from using two different machines? Is this a matter of industry standards or best practices?

Thank you so much!!

Celestine Jeffreys
Chief of Staff, Mayor's Office
City of Green Bay

Johanna Juris

From: Judnic, Nathan - ELECTIONS
<Nathan.Judnic@wisconsin.gov>
Sent: Tuesday, November 03, 2020 1:03 PM
To: Wolfe, Mcagan - ELECTIONS; Rydecki, Richard H -
ELECTIONS
Subject: FW: C-Green Bay Central Count concerns

FYI.

Nathan W. Judnic

Staff Attorney
Wisconsin Elections Commission
212 East Washington Ave, Third Floor
P.O. Box 7984
Madison, WI 53707-7984
608.267.0953 (direct)
608.228.7697 (cell)
608.267.0500 (fax)
nathan.judnic@wi.gov

From: Judnic, Nathan - ELECTIONS
Sent: Tuesday, November 03, 2020 1:03 PM
To: 'Juno, Sandy L.' <Sandy.Juno@browncountywi.gov>
Subject: RE: C-Green Bay Central Count concerns

Hi Sandy, thanks for the email. We've had several conversations with Green Bay leading up to today and are aware that they were going to be using consultants from some outside groups today. We've discussed the roles these individuals were going to be assigned and told them that while there is nothing that would prohibit the City of from using these individuals, the inspectors and the absentee board of canvassers working the location are the individuals that are to be making decisions, not the consultants. I have talked to Kim, the Deputy Clerk who was going to reach out to the central count folks and reinforce this guidance.

I would certainly like to be made aware of issues or decisions that have been "tainted" at the central count, I'm not 100% sure what you mean. As far as grant money, etc., I'm again interested if there are issues or decision that have been made that you think we should look into. I'm only really aware of the recent litigation related to grants given to municipalities which included Green Bay, Milwaukee, Madison and a couple others, but I was under the impression that case was dismissed and the US Supreme Court chose not to take it up prior to the election.

Let me know if there is anything else I can help with on this.

Thanks
Nate

Nathan W. Judnic

Staff Attorney
Wisconsin Elections Commission
412 East Washington Ave, Third Floor
P.O. Box 7984
Madison, WI 53707-7984
608.267.0953 (direct)
608.228.7697 (cell)
608.267.0500 (fax)
nathan.judnic@wi.gov

From: Juno, Sandy L. <Sandy.Juno@browncountywi.gov>
Sent: Tuesday, November 03, 2020 11:59 AM
To: Judnic, Nathan - ELECTIONS <Nathan.Judnic@wisconsin.gov>
Subject: C-Green Bay Central Count concerns
Importance: High

Nate, I have concerns about this person from an outside organization at the central county location for the City of Green Bay. I observed that he has a laptop, printer, and cell phone assessible within the central count facility. Likewise, we were told he is an observer for the outside organization that gave them a grant and his position is paid for by that even though he's from a different org. I observed him interacting with the poll workers and advising them on matters.

I believe the central count location is tainted by the influence of a person working for an outside organization affecting the election.

Please explain how grant money from a private outside organization and employee from a private outside organization does not violate election laws for free and fair elections?

Sandy Juno

Sandy Juno
Brown County Clerk
305 E. Walnut St., Room 120
Green Bay, WI 54301
920.819.9046 mobile
920.448.4021 office

From: Michael Spitzer-Rubenstein <michael@voteathome.org>
Sent: Wednesday, October 28, 2020 10:02 AM
To: Juno, Sandy L. <Sandy.Juno@browncountywi.gov>
Subject: Question about Green Bay Central Count

Hi Sandy,
I'm Michael Spitzer-Rubenstein, an advisor to the City of Green Bay through the National Vote at Home Institute. I'm helping the city set up Central Count for Tuesday.

I heard from Kim there was some sort of issue with using DS200s at Central Count. I'm trying to get the full backstory to advise her and the mayor. Do you have a moment to speak this morning? My cell phone is 310-980-2872.

Thank you,
Michael

Michael Spitzer-Rubenstein
State Lead for Wisconsin (Leadership Now Fellow)
National Vote at Home Institute
(310) 980-2872
he/him



Learn more about:

[Election Officials Center](#)

[Mail Ballot FAQs](#)

[Mail Ballot Security](#)

***** IMPORTANT CONFIDENTIALITY NOTICE ***** This electronic transmission, along with any information attached may contain confidential, proprietary, or privileged information, subject to, among other protections, the Health Insurance Portability & Accountability Act of 1996, codified as 45 C.F.R. Part 160; the Public Health Service Act, codified as 42 C.F.R. Part 2; and the attorney-client/attorney work-product statutory and common law privileges. If the reader of this transmission is not the intended recipient, you are hereby notified that any disclosure, copying, distribution or use of the information contained in or attached to this email is strictly prohibited. If you have received this email in error, please immediately notify the sender via return e-mail, then delete the email and any of its attachments, without reading or saving the email.

Johanna Juris

From: Rydecki, Richard H - ELECTIONS
<IMCEAEX-_O=EXCHANGELABS_OU=EXCHANGE+
20ADMINISTRATIVE+20GROUP+20+
28FYDIBOHF23SPDLT+29
_CN=RECIPIENTS_CN=USERD547D80F@legis.state.
wi.us>
Sent: Monday, November 09, 2020 3:08 PM
To: Rep.Tusler
Cc: Wolfe, Meagan - ELECTIONS
Subject: FW: C-Green Bay Central Count concerns

William,

Per your request I have provided the email thread below from Brown County Clerk Sandy Juno and our office. As Attorney Judnic outlines in his response, we had a number of calls with the city clerk's office in Green Bay leading up to the election to ensure they had the support and resources necessary to be successful on election day. Administrator Wolfe and I initiated several calls whose purpose was to confirm that the clerk's office felt like they were still in charge of running both central count and polling places on election day after we heard secondhand concerns that other entities were intervening in the planning process. Each time, we were assured by clerk's staff that they were leading these efforts and that the deputy clerk was overseeing the polling places for election day and her colleague was supervising central count. We asked them specifically about any concerns they had about decision making and feeling that they were not involved in making these decisions. The only instance they expressed concern about was when the City decided to move the central count operation to a different facility prior to election day due to setup and space concerns that would have made it difficult for observers to see the entire ballot processing from one observation area. The previous facility would have had ballots being processed on multiple floors and they ended up choosing a different facility after concerns were raised from observer groups about that setup. We were assured on several other occasions that the clerk's staff was running the election and that the consultants were there to provide feedback and suggestions but were not the ultimate decision makers.

Let me know if you have any other questions and I will be happy to assist.

Best,

Richard Rydecki
Assistant Administrator
Wisconsin Elections Commission
212 East Washington Avenue, Third Floor
Madison, WI 53703
Phone: (608)261-2015

From: Judnic, Nathan - ELECTIONS <Nathan.Judnic@wisconsin.gov>
Sent: Tuesday, November 03, 2020 1:03 PM

To: Wolfe, Meagan - ELECTIONS <Meagan.Wolfe@wisconsin.gov>; Rydecki, Richard H - ELECTIONS <Richard.Rydecki@wisconsin.gov>
Subject: FW: C-Green Bay Central Count concerns

FYI.

Nathan W. Judnic

Staff Attorney
Wisconsin Elections Commission
212 East Washington Ave, Third Floor
P.O. Box 7984
Madison, WI 53707-7984
608.267.0953 (direct)
608.228.7697 (cell)
608.267.0500 (fax)
nathan.judnic@wi.gov

From: Judnic, Nathan - ELECTIONS
Sent: Tuesday, November 03, 2020 1:03 PM
To: 'Juno, Sandy L.' <Sandy.Juno@browncountywi.gov>
Subject: RE: C-Green Bay Central Count concerns

Hi Sandy, thanks for the email. We've had several conversations with Green Bay leading up to today and are aware that they were going to be using consultants from some outside groups today. We've discussed the roles these individuals were going to be assigned and told them that while there is nothing that would prohibit the City of from using these individuals, the inspectors and the absentee board of canvassers working the location are the individuals that are to be making decisions, not the consultants. I have talked to Kim, the Deputy Clerk who was going to reach out to the central count folks and reinforce this guidance.

I would certainly like to be made aware of issues or decisions that have been "tainted" at the central count, I'm not 100% sure what you mean. As far as grant money, etc., I'm again interested if there are issues or decision that have been made that you think we should look into. I'm only really aware of the recent litigation related to grants given to municipalities which included Green Bay, Milwaukee, Madison and a couple others, but I was under the impression that case was dismissed and the US Supreme Court chose not to take it up prior to the election.

Let me know if there is anything else I can help with on this.

Thanks
Nate

Nathan W. Judnic

Staff Attorney
Wisconsin Elections Commission
212 East Washington Ave, Third Floor
P.O. Box 7984
Madison, WI 53707-7984
608.267.0953 (direct)
608.228.7697 (cell)
608.267.0500 (fax)
nathan.judnic@wi.gov

From: Juno, Sandy L. <Sandy.Juno@browncountywi.gov>
Sent: Tuesday, November 03, 2020 11:59 AM
To: Judnic, Nathan - ELECTIONS <Nathan.Judnic@wisconsin.gov>
Subject: C-Green Bay Central Count concerns
Importance: High

Nate, I have concerns about this person from an outside organization at the central county location for the City of Green Bay. I observed that he has a laptop, printer, and cell phone assessible within the central count facility. Likewise, we were told he is an observer for the outside organization that gave them a grant and his position is paid for by that even though he's from a different org. I observed him interacting with the poll workers and advising them on matters.

I believe the central count location is tainted by the influence of a person working for an outside organization affecting the election.

Please explain how grant money from a private outside organization and employee from a private outside organization does not violate election laws for free and fair elections?

Sandy Juno

Sandy Juno
Brown County Clerk
305 E. Walnut St., Room 120
Green Bay, WI 54301
920.819.9046 mobile
920.448.4021 office

From: Michael Spitzer-Rubenstein <michael@voteathome.org>
Sent: Wednesday, October 28, 2020 10:02 AM
To: Juno, Sandy L. <Sandy.Juno@browncountywi.gov>
Subject: Question about Green Bay Central Count

Hi Sandy,

I'm Michael Spitzer-Rubenstein, an advisor to the City of Green Bay through the National Vote at Home Institute. I'm helping the city set up Central Count for Tuesday.

I heard from Kim there was some sort of issue with using DS200s at Central Count. I'm trying to get the full backstory to advise her and the mayor. Do you have a moment to speak this morning? My cell phone is 310-980-2872.

Thank you,
Michael

Michael Spitzer-Rubenstein
State Lead for Wisconsin (Leadership Now Fellow)
National Vote at Home Institute
(310) 980-2872

he/him



[Learn more about:](#)

[Election Officials Center](#)

[Mail Ballot FAQs](#)

[Mail Ballot Security](#)

***** IMPORTANT CONFIDENTIALITY NOTICE ***** This electronic transmission, along with any information attached may contain confidential, proprietary, or privileged information, subject to, among other protections, the Health Insurance Portability & Accountability Act of 1996, codified as 45 C.F.R. Part 160; the Public Health Service Act, codified as 42 C.F.R. Part 2; and the attorney-client/attorney work-product statutory and common law privileges. If the reader of this transmission is not the intended recipient, you are hereby notified that any disclosure, copying, distribution or use of the information contained in or attached to this email is strictly prohibited. If you have received this email in error, please immediately notify the sender via return e-mail, then delete the email and any of its attachments, without reading or saving the email.

Deanna Debruler

From: Michael Spitzer-Rubenstein <michael@voteathome.org>
Sent: Friday, August 21, 2020 10:03 AM
To: ClerkInquiries
Cc: Hillary Hall
Subject: Following up on CTCL request

Hi Kris,

I'm Michael Spitzer-Rubenstein, the Wisconsin State Lead for the National Vote at Home Institute. You may have heard from Hillary Hall, our Senior Advisor for State and Local Election Officials but I wanted to personally reach out to you about the election communications assistance Green Bay requested from the Center for Technology and Civic Life.

Do you have 30 minutes to talk next week? I'd like to meet you, hear about your experience in the primaries, and share how we can help you over the next 74 days.

You might find our [Communications Toolkit](#) useful. It's a groundbreaking resource that uses behavioral science insights from our partners at ideas42 to help you connect with communities and get voters the information they need about voting in November. We know it's tough for cash-strapped election offices to build out a comprehensive communications plan, design compelling visuals and develop messaging documents. That's why our toolkit does all of that for you!

It includes a templated communications plans for election offices that's cohesive, strategic, and customizable, so you have a clear roadmap. We've also created inviting visuals in a variety of sizes that you can use for social media, print ads, fliers posters or whatever is needed!

I know you already had to deal with poll worker shortages and delayed ballots in the primaries. Now, you're probably preparing for a massive increase in mail-in absentee ballots. The National Vote at Home Institute has your back. [Our Communications Toolkit](#) is just one of the many resources we can offer you.

Are there any times next week that would be good for a brief conversation about how we can be of assistance? I'm happy to be flexible around your schedule.

Looking forward to speaking,
Michael

—
Michael Spitzer-Rubenstein
State Lead for Wisconsin (Leadership Now Fellow)
National Vote at Home Institute
(██████████)
he/him





CENTER FOR
TECH AND
CIVIC LIFE

May 28, 2020

City of Racine

Dear Mayor Mason,

I am pleased to inform you that the Center for Tech and Civic Life ("CTCL") has decided to award a grant to support the work of the City of Racine.

The following is a description of the grant:

AMOUNT OF GRANT: One hundred thousand US dollars (USD \$100,000).

PURPOSE: The grant funds must be used exclusively for the public purpose of planning safe and secure election administration in the City of Racine in 2020, and coordinating such planning with other cities in Wisconsin.

Before we transmit these funds, we ask that you sign this agreement promising to use the grant funds in compliance with United States tax laws. Specifically, by signing this letter you agree to the following:

1. The City of Racine is a U.S., state, or local government unit or political subdivision in the meaning of 26 USC 170(c)(1).
2. This grant shall be used *only* for the public purpose described above, and for no other purposes.
3. The City of Racine shall not use any part of this grant to give a grant to another organization unless CTCL agrees to the specific grant in writing, except as provided in paragraph 4.
4. The City of Racine shall grant ten thousand dollars (USD \$10,000) under this agreement to each of the cities of Green Bay, Kenosha, Madison, and Milwaukee solely for the public purpose of planning safe and secure election administration in those cities in 2020, and

00393

solely upon written confirmation from those entities that the funds shall be used for such purpose.

5. The City of Racine, and any cities granted funds under paragraph 4, shall produce, by June 15th, 2020, a plan for safe and secure election administration in each such city in 2020, including an assessment of election administration needs, budget estimates for such assessment, and an assessment of the impact of the plan on voters.
6. CTCL may discontinue, modify, withhold part of, or ask for the return all or part of the grant funds if it determines, in its sole judgment, that (a) any of the above conditions have not been met or (b) it must do so to comply with applicable laws or regulations.

Your acceptance of these agreements should be indicated below. Please have an authorized representative of The City of Racine sign below, and return a scanned copy of this letter to us by email at grants@techandcivicliflife.org.

On behalf of CTCL, I extend my best wishes in your work.

Sincerely,



Tiana Epps Johnson
Executive Director
Center for Tech and Civic Life

Accepted on behalf of the City of Racine:

By: _____

Title: _____

Date: _____





Wisconsin Safe Voting Plan 2020
Submitted to the Center for Tech & Civic Life
June 15, 2020

The State of Wisconsin found itself in the midst of an historic election in April of 2020 when statewide elections occurred in the midst of the COVID-19 pandemic. These elections included not only the presidential preference vote, but also local races for city councils, county boards, school board, and mayors, a statewide election for a seat on the Wisconsin Supreme Court, and numerous district-wide school referenda.

Municipalities were required to make rapid and frequent adjustments to ensure compliance with the rapidly changing Supreme Court, Wisconsin Supreme Court, and Wisconsin Election Commission (WEC) rulings about the election. (The April 2020 Election may go down in history as the only election in which the Wisconsin Supreme Court and the US Supreme Court weighed in on the same day on how the election would be conducted.)

The shifting legal landscape was also complicated by the extraordinary lengths municipal clerks went to to ensure that both voting and election administration were done in accordance with prevailing public health requirements.

As mayors in Wisconsin's five biggest cities - Milwaukee, Madison, Green Bay, Kenosha, and Racine - we seek to work collaboratively on the two remaining 2020 elections (August 11th and November 3rd) to: safely administer elections to reduce the risk of exposure to coronavirus for our residents as well as our election officials and poll workers; identify best practices; innovate to efficiently and effectively educate our residents about how to exercise their right to vote; be intentional and strategic in reaching our historically disenfranchised residents and communities; and, above all, ensure the right to vote in our dense and diverse communities.

Table 1: Summary of Municipalities' Electorate Data, June 2020

	Green Bay	Kenosha	Madison	Milwaukee	Racine
Estimated Eligible Voters	71,661	73,000	213,725	430,000	56,000
Registered Voters	52,064	47,433	178,346	294,459	34,734
2020 Election Budget	\$329,820	\$205,690	\$2,080,283	\$2,986,810	\$409,529

All five jurisdictions share concerns about how to best facilitate voter participation and limit exposure to coronavirus. All five jurisdictions spent all or most of the budgeted resources for all of 2020 on the extraordinary circumstances this Spring. If no plan is approved, it will leave communities like ours with no choice but to make tough decisions between health and the right to vote; between budget constraints and access to fundamental rights. The time that remains between now and the November Election provides an opportunity to plan for the highest possible voter turnouts in the safest possible ways.

We are collectively requesting a total of \$6,324,527 as summarized in Table 3 below and detailed extensively in the plan.

Review of the April 2020 Election

The April 2020 election placed two sacred duties of cities in conflict: keeping our residents safe and administering free and fair elections. Since Wisconsin's elections are administered at the municipal level, each municipality was on its own to deal with these dynamics. Our Municipal Clerks and their staff are all remarkable public servants, who responded nimbly and effectively to marshal the resources needed to run these elections under exceedingly challenging circumstances. In this election, all five of our municipalities faced:

- Precipitous drop-offs of experienced poll workers;
- A scramble to procure enough PPE to keep polling locations clean and disinfected and to mitigate COVID-19 risk for election officials, poll workers, and voters;
- A never-before-seen increase in absentee ballot requests;
- High numbers of voters who struggled to properly submit required photo ID and/or provided insufficient certification of absentee ballot envelopes; and
- Voters who, understandably, were completely confused about the timeline and rules for voting in the midst of a pandemic and required considerable public outreach and individual hand-holding to ensure their right to vote.

See Table 2, below, for detailed data on all five municipalities' April 2020 absentee mail and in-person early voting experiences.

Table 2: Summary of Municipalities' Experiences in April 2020 Election

	Green Bay	Kenosha	Madison	Milwaukee	Racine
# of voters who requested absentee ballots for April election	15,509	16,017	89,730	96,712	11,615
# of absentee ballots successfully cast in April	11,928	13,144	77,677	76,362	9,570
# of absentee ballot requests unfulfilled due to insufficient photo ID	Unknown	Unknown	1,840	2.5%	Estimated hundreds
# of absentee ballots rejected due to incomplete certification	312	196	618	1,671	368
# of secure drop-boxes for absentee ballot return	1	2	3	5	1
# of days of early voting	12	10	19	14	13
Use curbside voting for early voting?	✓	✗	✓	✓	✓
# of voters who voted in-person early absentee	778	85	4,930	11,612	1,543
# of additional staff enlisted for election-related efforts	86	60	225	95	20
\$ spent on PPE	\$2,122	\$13,000	\$6,305	Unknown	Unknown
# of polling locations	2	10	66	5	14
Use drive-thru or curbside voting on Election Day?	✓	✗	✓	✓	✓

Comprehensive Election Administration Needs for 2020

In early June 2020, all five municipal clerks and their staff, with review and support from all five cities' Mayors and Mayoral staff, completed a detailed, multi-page template (attached) providing both data and information about the municipalities' election plans and needs. This Wisconsin Safe Voting Plan 2020 is based on that comprehensive information. All five of our municipalities recommend the following four strategies to ensure safe, fair, inclusive, secure, and professional elections in our communities for the remaining 2020 elections:

Recommendation I: Encourage and Increase Absentee Voting (By Mail and Early, In-Person)

1. Provide assistance to help voters comply with absentee ballot requests & certification requirements
2. Utilize secure drop-boxes to facilitate return of absentee ballots
3. Deploy additional staff and/or technology improvements to expedite & improve accuracy of absentee ballot processing
4. Expand In-Person Early Voting (Including Curbside Voting)

Recommendation II: Dramatically Expand Strategic Voter Education & Outreach Efforts, Particularly to Historically Disenfranchised Residents

Recommendation III: Launch Poll Worker Recruitment, Training & Safety Efforts

Recommendation IV: Ensure Safe & Efficient Election Day Administration

As detailed in this plan, our municipalities are requesting **a total of \$6,324,567** to robustly, swiftly, comprehensively, and creatively implement these four strategic recommendations in each of our communities. That request is summarized as follows in Table 3, below, and detailed extensively in the remainder of this plan.

Table 3: Summary of Resources Needed to Robustly Implement All Four Recommendations

Recommendation	Green Bay	Kenosha	Madison	Milwaukee	Racine	Totals
Encourage and Increase Absentee Voting By Mail and Early, In-Person	\$277,000	\$455,239	\$548,500	\$998,500	\$293,600	\$2,572,839
Dramatically Expand Strategic Voter Education & Outreach Efforts	\$215,000	\$58,000	\$175,000	\$280,000	\$337,000	\$1,065,000
Launch Poll Worker Recruitment, Training & Safety Efforts	\$174,900	\$145,840	\$507,788	\$800,000	\$181,500	\$1,810,028
Ensure Safe & Efficient Election Day Administration	\$426,500	\$203,700	\$40,500	\$76,000	\$130,000	\$876,700
Totals:	\$1,093,400	\$862,779	\$1,271,788	\$2,154,500	\$942,100	\$6,324,567

Recommendation I: Encourage & Increase Absentee Voting By Mail and Early, In-Person

Of all the things that need to be done to ensure access and safety at the polls, this is perhaps the most important and timely. It is time, resource, and labor intensive but results in the voter being able to vote by mail or from the relative safety of their car or at a socially distanced and carefully planned early voting site.

Overview of Absentee Voting in Wisconsin

Before discussing our strategies and plans to encourage and increase absentee voting, both by mail and in-person, early voting, it's important to first understand the absentee voting context in Wisconsin.

There are two ways to vote early in Wisconsin: in-person and through the mail. Both are technically called "absentee voting," a phrase held over from a time when absentee voting required you to affirm that you were over 80, ill, or going to be out of the municipality on Election Day. Those requirements no longer exist in the statutes, and people can vote early, or absentee, for any reason. The April 2020 election saw dramatic increases in the number of absentee ballot requests over previous elections.

While for many regular voters, absentee voting - whether completed by mail or early, in-person - is a relatively easy process, our five cities understand that absentee voting does not work easily for all voters. Our communities of color, senior voters, low-income voters without reliable access to the internet, people with disabilities, and students all have legitimate concerns about the absentee voting process.

Voting absentee by mail has been complicated by the fairly recent imposition of state law requiring voters to provide an image of their valid photo ID prior to first requesting an absentee ballot. While this works relatively easily for voters who have valid photo IDs and the technology necessary to upload an image file of that valid ID into the state's myvote.wi.gov website, it does not work well or easily for other voters who do not have valid photo ID (complicated by closure of DMVs due to the pandemic), lack access to reliable internet (also complicated by coronavirus-related closures or reduced hours at libraries and community centers, leaving those residents without regular public internet access that our municipalities normally provide), those who don't have smart phones to take and upload photos, and those who need additional education about what constitutes a valid photo ID. (For example, countless voters in our municipalities attempted to submit "selfies" as valid photo ID. Explaining to them that this was not a valid form of photo ID and instructing them on how to properly submit valid ID took considerable staff time and resources.)

Once the absentee ballot is received, it must be completed correctly to be successfully cast, and there are numerous certification requirements on the absentee ballot envelope; if not correctly completed, the ballot could be rejected. Prior to this April's

election, very small numbers of voters had traditionally chosen to cast ballots by mail. Municipal clerks' offices simply were not prepared and do not have the staffing or technological resources needed to quickly process dramatically higher numbers of absentee ballot requests, troubleshoot problems, answer voter questions, provide information and to expedite the processing of thousands of received absentee ballots on Election Day.

In-person early absentee voting also poses challenges for voters and election administrators. While all of our communities had previously offered early voting locations and hours, April's election required election officials to creatively and quickly expand in-person early voting opportunities, including curbside voting, all while prioritizing necessary COVID-19 precautions.

As indicated by Table 4, below, all five of our municipalities are already experiencing dramatic increases in the number of voters requesting to vote absentee, compared to pre-pandemic, and must procure resources to enable voters in our communities to meaningfully access absentee voting.

Table 4: Absentee Ballots in All Municipalities as of June 2020

	Green Bay	Kenosha	Madison	Milwaukee	Racine
# of voters on permanent absentee list prior to 2/18/20	1,628	1,856	2,062	6,252	613
# of voters on permanent absentee list as of 4/7/20	4,306	3,469	8,665	23,374	2,684
# of voters who have already requested absentee ballots for August 2020	5,162	9,450	36,092	53,438	3,389
# of voters who have already requested absentee ballots for November 2020	4,859	9,123	34,164	50,446	3,204

We are committed to making voting accessible via mail, in-person prior to Election Day, and at the polls on Election Day. Particularly in the midst of a global pandemic when many voters are rightfully apprehensive about in-person voting, we want to ensure that voters in our communities know they have options and we are committed to conducting the necessary voter outreach and education to promote absentee voting and encourage higher percentages of our electors to vote absentee.

Increasing the number of voters who cast votes prior to Election Day minimizes the risk of spreading COVID-19 on Election Day from in-person contacts at our polling locations, and it reduces the chance for lines and delays in voting on Election Day.

The Wisconsin Election Commission (WEC) has approved a proposal to mail all registered voters absentee ballot request forms, which allows our five communities to focus on helping voters overcome the barriers to successfully returning those forms so they can obtain, and then successfully submit, their completed absentee ballots. This measure will provide absentee request information directly to voters, alleviating the need for municipalities to expend the cost to send the mailing. However, it is unclear how this measure will affect the workload of municipal clerks. Although the WEC has directed that the forms be returned to the WEC for entry, municipal clerks must still review each record, process, mail, record receipt and canvass each absentee ballot.

All of our municipalities anticipate continued large increases in absentee voting based on the April 2020 trends. Milwaukee, for example, anticipates that 80% of residents will vote absentee by mail for both the August primary and the November general election.

All five cities have identified numerous barriers to successful absentee voting, including: voters facing numerous challenges to successfully submitting valid photo ID; voters needing assistance complying with absentee ballot certification requirements, including obtaining the required witness signature on the absentee ballot return envelope; the labor-intensive process faced by all of our clerks' offices of processing absentee ballot requests; and U.S. Postal Service errors and mail delays. All of these are challenges for our municipalities in normal elections, but they are all compounded by the coronavirus pandemic, and made exponentially more difficult by the unprecedented volume of absentee voting requests. This puts tremendous strain on municipal election clerks and their staff.

Our five cities share the desire to assist as many residents as possible with casting ballots before Election Day, serving as the greatest opportunity we have to mitigate the spread of COVID-19 in our communities. We have identified several strategies to help voters in each of our communities overcome these barriers to successful absentee voting, both by mail and in-person early voting.

Overall, our five communities are requesting **\$2,572,839** in resources related to enabling our municipalities to overcome these particular barriers and ensure that our voters can meaningfully access absentee voting, both by mail and in-person early voting. These strategies and resource needs are broken down into four distinct component recommendations, within the overall umbrella of increasing and encouraging absentee voting:

1. Provide assistance to help voters comply with absentee ballot requests & certification requirements

- **Green Bay:** The City would like to employ bilingual LTE “voter navigators” (\$45,000) to help residents properly upload valid photo ID, complete their ballots and comply with certification requirements, and offer witness signatures. These voter navigators can assist voters prior to the elections and then also be trained and utilized as election inspectors. They would also like to utilize paid social media and local print and radio advertising to educate and direct voters in how to upload photo ID and how to request and complete absentee ballots. (\$2,000)
Total: \$47,000
- **Kenosha:** The City would like to have Clerk’s staff train library staff on how to help residents request and complete absentee ballots, would like to produce (\$3,000) and mail (\$26,200) a bilingual absentee ballot instruction sheet with all absentee ballots to increase correctly completed and submitted ballots. The City would like to hire a trainer for seasonal election workers, volunteers and poll workers. This employee would also coordinate assignments to polling locations, the early driver up voting site, the Clerk’s office for assistance in processing, data entry and filing of absentee requests and the Absentee Board of Canvassers (approximately \$50,000). The increase in absentee ballots due to COVID-19 has tremendously increased the workload of the department. In order to properly serve the citizens and voters additional LTE employees are needed (approximately \$175,000). **Total: \$254,200**
- **Madison:** Plans to hold curbside “Get your ID on File” events with the Clerk this summer utilizing volunteers or paid poll workers (\$15,000) equipped with PPE (estimated \$5,000) and digital cameras (\$4,500) to capture voter ID images for voters who are unable to electronically submit their IDs to the Clerk’s office. They also need large flags to draw attention to these curbside sites (\$4,000). Would also like mobile wifi hotspots and tablets for all of these sites (\$100,000) so voters could complete their voter registration and absentee requests all at once, without having to wait for staff in the Clerk’s office to follow up on paper forms. (These mobile wifi hotspots, tablets, and flags, could all then be repurposed for early in-person voting closer to the election.) **Total: \$128,500**
- **Milwaukee:** The City notes that the biggest obstacle to Milwaukee residents, particularly those in poverty, to applying for an absentee ballot in April was access to the internet and securing an image of their photo ID. To address this, the City will be promoting and utilizing Milwaukee Public Library branch staff (\$90,000 for both elections) for 3 weeks prior to each election to assist any potential absentee voters with applying, securing, and uploading images of their valid photo ID. **Total: \$90,000**
- **Racine:** The City will recruit and promote (\$1,000), train (\$3,000), and employ paid Voter Ambassadors (\$8,000) who will be provided with both PPE and

supplies (\$4,000) and set up at the City's community centers to assist voters with all aspects of absentee ballot request, including photo ID compliance. Due to the increase of absentee mailed requests the City of Racine will need an additional 2 full time staff members in the Clerk's Office in order to have a reasonable turn-around time for absentee requests (\$100,000). Total: **\$116,000.**

Total: \$635,700

2. Utilize Secure Drop-Boxes to Facilitate Return of Absentee Ballots

Our five communities all share a desire to expand voters' ability to easily return absentee ballots to the municipality without having to rely on the postal service, since, after April's election, many voters are (rightfully) apprehensive that putting their completed ballot in the mail does not guarantee it will be received and counted by the municipality by statutory deadlines. Voters also need to have confidence that they are returning their completed absentee ballots into secure containers that are not at risk of tampering. All five cities need resources to purchase additional secure drop-boxes and place them at key locations throughout their cities, including libraries, community centers, and other well-known places, to ensure that returning completed ballots is as secure and accessible to voters throughout our cities as possible.

- **Green Bay:** The City would like to add secure (security cameras \$15,000) ballot drop-boxes (approximately \$900 each) at a minimum of the transit center and two fire stations, but if funding were available would also install secure drop boxes at Green Bay's libraries, police community buildings, and potentially several other sites including major grocery stores, gas stations, University of Wisconsin Green Bay, and Northern Wisconsin Technical College, in addition to the one already in use at City Hall. **Total: \$50,000**
- **Kenosha:** The City currently has two drop-boxes that are checked throughout the day, and would like to install 4 additional internal security boxes at Kenosha libraries and the Kenosha Water Utility so that each side of town has easy access to ballot drop-boxes. **Total: \$40,000**
- **Madison:** The City would like to have one secure drop box for every 15,000 voters, or 12 drop boxes total (\$36,000). The City would also like to provide a potential absentee ballot witness at each drop box, utilizing social distancing and equipped with PPE (staff costs unknown): **Total: \$50,000**
- **Milwaukee:** The City would like to install secure 24-hour drop boxes at all 13 Milwaukee Public library branches, staffed with socially distanced volunteers to serve as witnesses. **Total: \$58,500**

- **Racine:** The City currently has one secured drop box for absentee ballots, and would like to have 3 additional drop boxes, each equipped with security cameras, to install at key locations around the City. **Total: \$18,000.**

Total: \$216,500

3. Deploy Additional Staff and/or Technology Improvements to Expedite & Improve Accuracy of Absentee Ballot Processing

The process of assembling and mailing absentee ballots is labor-intensive, slow, and subject to human error. Absentee ballot requests must be approved and entered into the statewide system, labels must be printed and applied to envelopes, ballots must be initialed, folded, and inserted into the envelope along with instructions. Ballots must be logged when received back from the voter. Undeliverable ballots must be reviewed, reissued or canceled. When voters make mistakes on ballots the requests to reissue must be completed. These tasks are time-consuming and utilizing existing clerk's office staff pulls them away from all of the other service requests, phone answering, and tasks handled by busy municipal clerks' offices.

The tremendous increase in absentee ballot requests in April was unprecedented, and municipal clerks and their staff were unprepared for the volume. They responded remarkably well - particularly since many of their staff were, by late March and early April, working remotely or, at a minimum, all needing to adhere to social distancing and masking precautions when working together in the same room - but all five municipalities need additional resources to accurately and swiftly process absentee ballot requests.

- **Green Bay:** The City needs 45 additional staff to process absentee ballot requests before the election, to open and verify envelopes on Election Day, and insert them into the tabulators. After the election, staff are needed to enter new voter registrations and assist with all election certification tasks (\$140,000 for staffing) The City would also like to purchase a ballot opener and ballot folder to expedite processing (\$5,000). **Total: \$145,000.**
- **Kenosha:** The City needs resources for absentee ballot processing, to staff and process early, in-person absentee requests, and to answer voters' questions (approximately \$100,000). Additional workers are also needed to canvass absentee ballots (approximately \$11,000) **Total: \$111,000**
- **Madison:** Based on data from April, the City estimates it will need additional staffing (\$110,000) for hourly election clerks for the fall elections, and will incur

additional overtime costs (\$100,000) for staff processing of absentee ballots and other election-related tasks. **Total: \$210,000**

- **Milwaukee:** Given its tremendous volume of absentee ballot requests and processing tasks which far exceeds that of the other municipalities, Milwaukee would like to completely automate and expedite the assembly and mailing of requested absentee ballots. The City would like to purchase a high-speed, duplex printer, a top-of-the-line folding machine, and a high quality folding and inserting machine. This would reduce staff costs and eliminate the use of absentee labels, by enabling the City to print directly onto inner and outer envelopes. This would also allow the City to have a small 2D barcode that the inserter machine would be able to scan to ensure that the outer envelope is for the same voter; increasing quality controls. This automation would enable the City to eliminate the assembly delay no matter the volume of daily absentee requests, allowing experienced election workers and previously trained election temporary employees to be re-deployed to early voting sites as supervisors and lead workers. **Total: \$145,000**
- **Racine:** To process absentee ballot requests in April, the City estimates that it will need seven additional full-time employees to process fall election requests. These employees will be needed full-time for one month prior to the August Election (approximately \$17,000) and seven weeks prior to the November election (approximately \$30,000). **Total: \$47,000**

Total: \$658,000

4. Expand In-Person Early Voting (Including Curbside Voting)

For a variety of reasons, many voters in our municipalities do not want to vote by mail and prefer to vote in-person. As a result of the coronavirus, far more voters are interested in early, in-person absentee voting (EIPAV) than we've seen in previous elections, wishing to avoid lines or crowds on Election Day. All five municipalities would like to have resources to accommodate these early, in-person voters. Expanding access to early, in-person voting also will lessen lines at polling places on Election Day and allow for proper social distancing and other pandemic precautions to be uniformly implemented.

Curbside and drive-thru voting have been very popular with residents of our municipalities, particularly for those with health concerns who can remain in the cars and have a virtually contact-less voting process. For example, Milwaukee previously operated in-person early voting for one week leading up to the April election at three sites and then transitioned to one site of drive-thru voting. 11,612 cast ballots through these options: 5,571 via in-person and 6,041 at drive-thru, and these numbers represent a 46% increase over April 2016 "early voting" totals. However, it is slow-moving and

labor-intensive. Additionally, particularly in the larger cities among us, it requires law enforcement and traffic control assistance to help manage traffic.

- **Green Bay:** The City would like to expand and establish at least three EIPAV sites in trusted locations, ideally on the east (potentially UWGB) and west sides (potentially NWTC or an Oneida Nation facility) of the City, as well as at City Hall. The City is planning to offer early voting starting two weeks before each election, with several weekdays available until 6:30pm and Saturdays 10am-4pm. They would like to staff these early voting sites with election inspectors who are bilingual and would like to increase the salary rate for these bilingual election inspectors to assist with recruitment and retention, as well as in recognition of their important role at these sites. The City also will need to print additional ballots, signage, and materials to have available at these early voting sites. **Total: \$35,000.**
- **Kenosha:** The City plans to have one early voting location, at City Hall, and plans to hold early voting two weeks before the August election, with no weekend or evening hours planned, and 4 weeks before the November election, with access until 7pm two days/week and Saturday voting availability the week before the election. If City Hall is still closed to the public, they will explore offering early drive thru voting on City Hall property. Resources are needed for staffing (approximately \$40,000), PPE (\$1,050), signage (\$200), laptops, printers, and purchase of a large tent (\$8,789) to utilize for drive thru early voting. Staff could see voters' ID, print their label, hand them their ballot, and then collect the completed envelope. This would also allow staff to help voters properly do certification and provide witness signatures if necessary. The City could do this for one full week before elections. **Total \$50,039.**
- **Madison:** The City would like to provide 18 in-person absentee voting locations for the two weeks leading up to the August election, and for the four weeks leading up to the November election. Their original plan was to offer in-person absentee voting at all nine library locations, the City Clerk's Office, a city garage, Edgewood College, two Madison College locations, and four UW-Madison locations. Due to weather uncertainties, they will need to purchase and utilize tents (\$100,000) for the curbside voting locations in order to protect the ballots, staff, and equipment from getting wet and will also need large feather flags to identify the curbside voting sites. (Additional staff costs covered by the earlier question re. Absentee ballot processing.) The City would also like to get carts (\$60,000) for our ExpressVote accessible ballot marking devices so we can use the ExpressVote for curbside voting to normalize the use of ExpressVote to help voters with disabilities feel less segregated during the voting process. **Total: \$160,000.**
- **Milwaukee:** The City would like to set up 3 in-person early voting locations for two weeks prior to the August election (\$150,000) and 15 in-person early voting

locations and 1 drive-thru location, potentially at a central location like Miller Park, for four weeks prior to the November election (\$450,000). (Establishing this many EIPAV sites requires a significant investment in IT equipment, an additional ballot printer, tents, signage, and traffic control assistance. Milwaukee would also like to offer evening and weekend early voting hours which would add additional costs for both August (\$30,000) and November (\$75,000). **Total: \$705,000.**

- **Racine:** The City would like to offer a total of 3 EIPAV satellite locations for one week prior to the August election, as well as offering in-person early voting - curbside, if City Hall is still closed to the public - at the Clerk's office for 2 weeks prior to the August election. For the November election, Racine would like to offer EIPAV at 4 satellite locations two weeks prior to the election and at the Clerk's office (again, potentially curbside) 6 weeks prior. The City would need to obtain PPE, tents, supplies and cover staff time and training (\$40,000). Racine would also like to have all satellite locations available for half-day voting the two Saturdays (\$17,000) and Sundays (\$17,000) prior to the November election, and the library and mall locations would be open until 8pm the week prior to the Election. Additional resources needed include one-time set-up fee per location (\$7,500), laptops and dymo printers (\$10,000), training (\$1,100), and signage (\$12,000.) As well, the City would like to host at least one drive-thru Voter Registration Day, where City Hall would be set up for residents to come get registered, curbside, and get their voting questions answered by Clerk's staff. Newly registered voters could also get assistance requesting absentee ballots for upcoming elections while they're there. (\$8,000) **Total: \$112,600**

Total: \$1,062,639.00

Recommendation I Total for All Strategies to Encourage and Increase Absentee Voting by Mail and Early, In-Person: \$2,572,839.00

Recommendation II: Dramatically Expand Voter & Community Education & Outreach, Particularly to Historically Disenfranchised Residents

All five municipalities expressed strong and clear needs for resources to conduct voter outreach and education to their communities, with a particular emphasis on reaching voters of color, low-income voters without reliable access to internet, voters with disabilities, and voters whose primary language is not English. This outreach is particularly necessary given the voter confusion that ensued in the lead-up to the April election, and voters' concerns and questions about voting during the COVID-19 pandemic. We understand that our communities of color do not necessarily trust the voting process, and that we need to work to earn that trust. We want to be transparent and open about what happens behind the scenes in elections, and what options are available for casting a ballot. We also want to make sure we are listening to groups that have historically been disenfranchised and groups that are facing obstacles with voting during this pandemic, and working with them to effectively respond to their concerns.

Voter outreach and education is also needed to encourage and explain new voter registration, and to encourage voters to verify and update their address or other voter registration information to do so prior to the Election. None of our communities have sufficient resources budgeted or available for the strategic, intentional, and creative outreach and education efforts that are needed in our communities over the summer and into the fall.

We all want our communities to have certainty about how the voting process works, trust in our election administration's accuracy, and current, accurate information on what options are available to vote safely in the midst of the pandemic. Significant resources are needed for all five municipalities to engage in robust and intentional voter education efforts to reduce confusion; encourage and facilitate new voter registration and registration updates; provide clear, accessible, and accurate information; address voters' understandable pandemic-related safety concerns; reassure voters of the security of our election administration; and, ultimately, reduce ballot errors and lost votes and enhance our residents' trust and confidence in our electoral process.

- **Green Bay:** Would like to reach voters and potential voters through a multi-prong strategy utilizing "every door direct mail," targeted mail, geo-fencing, billboards, radio, television, and streaming-service PSAs, digital advertising, and automated calls and texts (\$100,000 total). The City would also like to ensure that these efforts can be done in English, Spanish, Hmong, and Somali, since roughly 11% of households in the Green Bay area speak a language other than English. Ideally, the City would employ limited term communications staff or engage communications consultants (\$50,000) from August through the November election to design these communications and design and launch paid advertising on Facebook, Twitter, and Instagram, also in multiple languages. The City would also like to directly mail to residents who are believed to be eligible but not registered voters, approximately 20,000 residents. It would require both

considerable staff time to construct that list of residents and directly mail a professionally-designed piece (in multiple languages) to those voters. (\$50,000 total for staffing, design, printing, and postage). To assist new voters, the City would also like resources to help residents obtain required documents (i.e. birth certificates) which are needed to get a valid state ID needed for voting. These grant funds (\$15,000) would be distributed in partnership with key community organizations including churches, educational institutions, and organizations serving African immigrants, LatinX residents, and African Americans.

Total: \$215,000

- **Kenosha:** Would like to directly communicate to all Kenosha residents via professionally-designed targeted mail postcards that include information about the voter's polling location, how to register to vote, how to request an absentee ballot, and how to obtain additional information. The City would have these designed by a graphic designer, printed, and mailed (\$34,000). The City would also like resources for social media advertising, including on online media like Hulu, Spotify, and Pandora (\$10,000) and for targeted radio and print advertising (\$6,000) and large graphic posters (\$3,000) to display in low-income neighborhoods, on City buses, and at bus stations, and at libraries (\$5,000).
Total: \$58,000
- **Madison:** Would like to engage the City's media team to produce videos to introduce voters to the election process, voting options, and to explain the safety precautions taken at polls and early voting sites. These videos would then be shared in numerous ways, including through partner organizations and on the City's social media platforms. The City would also like to partner with community organizations and run ads on local Spanish-language radio, in the Spanish-language newspapers, on local hip hop radio stations, in African American-focused printed publications, and in online publications run by and for our communities of color (advertising total \$100,000). Additionally, the City has many poll workers who are from historically disenfranchised communities. The City would like to pay those poll workers (\$75,000) to conduct voter outreach and additional poll worker recruitment activities. **Total: \$175,000.**
- **Milwaukee:** Would like to partner with other City divisions to develop mailings and door hangers (\$10,000) that could accompany water bills, be distributed by the Department of Neighborhood Services, or hung on trash receptacles by sanitation staff. The City would also like to revamp current absentee voting instructions to be more visual, address issues specific to the pandemic such as securing a witness signature, prepare it in English and Spanish, and print 150,000 color copies (estimated total \$15,000). The Election Commission would also like to produce a short video (\$5,000) with visuals showing voters how to apply for an absentee ballot and how to correctly complete and return the ballot. Additionally, the Election Commission would like to hire a communications firm to prepare and implement a comprehensive voter outreach communications plan

(\$250,000). This communications effort would include numerous voter education ads and PSAs on radio, billboards, buses, with some using local celebrities like Milwaukee Bucks players. This communications effort would focus on appealing to a variety of communities within Milwaukee, including historically underrepresented communities such as LatinX and African Americans, and would include a specific focus on the re-enfranchisement of voters who are no longer on probation or parole for a felony. Additionally, this campaign would include an edgy but nonpartisan and tasteful communications campaign to harness the current protests' emphasis on inequity and ties that message to voting. The video, the ads, and the PSAs could all also be placed on social media, the Election Commission and City websites, and GOTV partner websites and social media. **Total: \$280,000**

- **Racine:** The City would like to retain a communications firm to design and implement a comprehensive voter outreach communications plan (\$80,000). This would include ads on Facebook, Instagram, and Snapchat. The City would also like to rent billboards in key parts of the City (\$5,000) to place messages in Spanish to reach Spanish-speaking voters. The City would also like to do targeted outreach aimed at City residents with criminal records to encourage them to see if they are not eligible to vote; this outreach will be accomplished with the production, editing, and sharing of a YouTube video (\$2,000) specifically on this topic shared on the City's website, social media channels, and through community partners. Racine would also like to purchase a Mobile Voting Precinct so the City can travel around the City to community centers and strategically chosen partner locations and enable people to vote in this accessible (ADA-compliant), secure, and completely portable polling booth on wheels, an investment that the City will be able to use for years to come. (Estimated cost \$250,000). **Total: \$337,000**

Recommendation II Total For All Strategies to Dramatically Expand Strategic Voter Education and Outreach Efforts, Particularly to Historically Disenfranchised Residents: \$1,065,000.00

Recommendation III: Launch Poll Worker Recruitment, Training, and Safety Efforts

The pandemic made conducting Election Day activities extremely challenging. Most poll workers in Wisconsin are retirees doing their civic duty to help facilitate the election. Given the increased risk for the elderly if exposed to COVID-19, many experienced poll workers opted out. Milwaukee had so many poll workers decline to serve that the City went from 180 polling locations to five polling locations. Green Bay, facing a similar exodus of poll workers, went down to two polling locations. Racine usually relies on nearly 190 poll workers for a spring election; only 25 of those experienced poll workers were under the age of 60.

As fears about the coronavirus increased in mid-late March and early April, poll workers in all five municipalities declined to work the election, leaving cities scrambling to quickly recruit enough bodies to keep polling locations open. All cities were appreciative of the last minute assignment of hundreds of Wisconsin National Guard members to assist with Election Day activities, and all of our cities re-assigned City staff from other departments to serve as poll workers and election officials and to assist with the myriad of tasks related to Election Day administration. The remainder of positions were staffed by high school students, college students, and members of the National Guard. Many of our poll workers had never worked an election before.

- **Green Bay:** The City needs to hire a total of 380 workers per election (total \$112,660). The City would like to pay poll workers more than they have previously received, to signify their importance in the process and to acknowledge the extra challenge it represents to serve as an election official during a pandemic. The City would like to increase poll worker salaries by 50% (additional \$56,330). All poll workers will be trained through the Wisconsin Elections Commission website and the City's own training manual (\$6,000). **Total: \$174,900**
- **Kenosha:** The City needs to hire 350 poll workers per election (\$100,000). They would like to offer hazard pay to increase pay to \$160/worker and \$220/chief inspectors (\$10,840). To aid in recruitment efforts, the City would like to hire a recruiter and liaison position for poll workers (\$35,000). **Total: \$145,840.**
- **Madison:** The City utilizes the election toolkit available through the MIT Technology Project to determine the staffing levels needed to ensure that voters will not have to wait in line for more than 15 minutes. In addition to the one Chief Inspector per polling location, Madison also has additional election officials who are certified as the Absentee Lead at each polling location. Madison estimates that if 75% of votes cast are absentee, the City will need 1,559 election officials at the polls in August. The City envisions a robust and strategic poll worker recruitment effort, focusing on people of color, high school students, and college students. The City would like to have resources for hazard pay for poll workers this fall at a rate comparable to what the U.S. Census is paying in the area

(\$369,788). The City has also found it challenging to convince facilities to host a polling location in the midst of a pandemic, and would like to provide each facility with a small amount of funds to compensate for their increased cleaning and sanitization costs (\$750/location, \$138,000 total). **Total: \$507,788**

- **Milwaukee:** The City plans to have 45 voting locations in August and to keep open as many of the normal 180 polling places as possible in November. August will require 3 chief inspectors per site and 20 election workers per site, for a total of 1200 election workers minimum and 150 chief inspectors. The City has a goal of recruiting 1,000 new election workers. The City would like to add an additional \$100 per worker in hazard pay to the poll workers' stipends of \$130 (\$460,000 additional for both elections) and \$100 hazard pay to chief inspector stipends of \$225 (\$87,750 additional for both elections). Additionally, the City of Milwaukee utilizes a Central Count of absentee ballots, which necessitates 15 chiefs and 200 election workers per election at Central Count (\$50,000/day for 2- days each election for a total of \$200,000). Total payroll for both elections will reach \$750,000 based upon these calculations. The City will launch a recruitment campaign for a new generation of election workers to sign up and be involved in their democracy, and hopes this effort can be included in the above request for resources for a marketing firm. Recruiting new and younger poll workers means that the Election Commission will need to innovate in election training. The Commission would like to produce polling place training videos (\$50,000) with live small-group, socially distanced discussions and Q&A sessions. These videos will augment existing training manuals. **Total: \$800,000**
- **Racine:** The City needs approximately 150 poll workers for August and 300 for November, in addition to 36 Chief Inspectors, and would like to pay all workers a \$100/election hazard pay (\$118,000 total payroll for both elections). City notes that its desire to have more early voting locations and hours is directly impacted by its ability to hire and train election officials. To that end, the City would like to launch a recruitment campaign that includes radio ads (\$1,000), ads on social media platforms (\$10,000), billboards in strategic City locations (\$5,000), and film videos for high school students in history/government classes (\$500). The City would also like to enlist a communication firm to: create a training video for election officials, develop an online quiz, detailed packets for election officials, and a PPE video filmed by a health professional about necessary COVID-19 precautions during all voting operations (\$22,000 total). Racine would also like to hire a liaison position to schedule, training and facilitate poll workers. (\$35,000) **Total: \$181,500.**

Recommendation III Total for All Strategies to Launch Poll Worker Recruitment, Training and Safety Efforts: \$1,810,028.00

Recommendation IV: Ensure Safe & Efficient Election Day Administration

It is no small task to mitigate risk of a lethal pandemic at all polling locations and throughout all required Election Day processing. Municipal clerks must ensure they have done everything possible to comply with public health guidelines and mitigate the risk of COVID-19 for all of the election officials, poll workers, observers, and voters. Our five municipalities are in need of numerous resources to both ensure seamless processing of voters on the upcoming Election Days, procure Personal Protective Equipment (PPE), disinfectant, and cleaning supplies to protect election officials and voters from the coronavirus, and to aid in processing of an expected high volume of absentee ballots. Additionally, as several of our municipalities move to add or expand drive-thru voting on Election Days, those expansions come with additional unbudgeted expenses for signage, tents, traffic control, publicity, and safety measures. All of our municipalities need resources to ensure that the remaining 2020 Election Days are administered seamlessly and safely.

- **Green Bay:** Green Bay would like to purchase 135 electronic poll books (\$2,100/each for a total of \$283,500) to reduce voter lines, facilitate Election Day Registrations and verification of photo ID. The City would also like a high speed tabulator (\$62,000) to count absentee ballots on Election Day, a ballot opener and ballot folder (\$5,000), and additional staff to process absentee ballots on Election Day (\$5,000). The City also needs masks, gloves, gowns, hair nets, face shields (\$15,000), cough/sneeze guards (\$43,000), and disinfectant supplies (\$3,000). **Total: \$426,500**
- **Kenosha:** The City would like to purchase automatic hand sanitizer dispensers for all polling locations (\$14,500) as well as PPE (gloves, masks, disinfectant, etc.) for all poll workers and voters (\$15,200). Kenosha would also like to be able to offer elderly residents and people with disabilities who wish to vote in person on Election Day two-way transportation, utilizing a local organization such as Care-A-Van (\$2,000). The City also needs resources for technology improvements to include a ballot opener, a ballot folder, 12 additional laptops and dymo printers, and high-speed scanner tabulators (\$172,000 total) to expedite election day processing and administration. **Total: \$203,700**
- **Madison:** The City needs hand sanitizer for all poll workers and voters, disinfectant spray, plexi-glass shields to allow poll workers to split the poll books, face shields for curbside election officials, and face masks for all poll workers and observers (\$20,000) as well as renting additional space to safely and accurately prepare all supplies and practice social distancing at the public test of election equipment (\$20,000) If the new voter registration form is not translated by the state into both Spanish and Hmong, Madison plans to translate the form (\$500). **Total: \$40,500**

- **Milwaukee:** The City will be purchasing 400 plexiglass barriers (\$55,000) for election workers at all polling location receiving and registration tables. Additionally, the Milwaukee Election Commission will need to acquire 400 face shields for workers not staffed behind plexiglass (\$4,000), gloves for all poll workers (\$3,000), masks on hand for election workers and members of the public (\$5,000), hand sanitizer (\$2,000) and disinfectant (\$2,000). Additionally, since Milwaukee also plans to offer curbside voting as an option at all polling places, updated, larger, more visible signage is necessary (\$5,000). **Total: \$76,000**
- **Racine:** Racine plans to issue all 36 wards its own PPE supply box which will each include masks, cleaning supplies, pens for each voter, gloves, hand sanitizer, safety vests, goggles, etc. (\$16,000). The City also needs large signs to direct and inform voters printed in English and Spanish (\$3,000). Additionally, the City would like to deploy a team of paid trained EDR Specialists for each polling location (\$10,000, including hourly pay, training expenses, and office supplies). As well, Racine would like iPads with cellular signal for each polling location to be able to easily verify voters' registration status and ward (\$16,000). The City would like to equip all wards with Badger Books (\$85,000); Racine began using electronic poll books in the February 2020 election and has found they dramatically increase and facilitate EDR, verification of voters' photo ID, expedite election processes, and reduce human error. **Total: \$130,000**

Recommendation IV Total for All Strategies to Ensure Safe & Efficient Election Day Administration: \$876,700.00

Conclusion

As Mayors in Wisconsin's five largest cities, we are committed to working collaboratively and innovatively to ensure that all of our residents can safely exercise their right to vote in 2020's remaining elections in the midst of the COVID-19 pandemic. The April 2020 election placed two of our most sacred duties in conflict: keeping our residents safe and administering free, fair, and inclusive elections. This Wisconsin Safe Voting Plan 2020 represents a remarkable and creative comprehensive plan, submitted collaboratively by all five of our cities. With sufficient resources, all five municipalities will swiftly, efficiently, and effectively implement the recommended strategies described in this plan, to ensure safe, fair, inclusive, secure, and professional elections in all of our communities this year.



City of Racine

City Hall
730 Washington Ave.
Racine, WI 53403
www.cityofracine.org

Legislative Report

File Number: Res. 0413-20

Agenda Date: 07/08/2020

File Type: Resolution

Grant from the Center for Tech and Civil Life (Grant Control Number 00306)

Resolved, that the Mayor and City Clerk be authorized to accept the funds from the Center for Tech and Civil Life in the amount of \$942,100.00 to help facilitate the Wisconsin Safe Voting Plan for 2020. (Grant Control Number 00306)

Fiscal Note: No city match is required.

File #	Type	Status	File Created	Final Action	Title
0573-20	Communication	Passed	9/1/2020	9/15/2020	Subject: Election of Officers Recommendation: Approve all Officers as Noted
0572-20	Communication	Passed	9/1/2020	9/15/2020	Subject: Election of Officers Recommendation: Approve all Officers as Noted
0571-20	Communication	Passed	8/28/2020	9/1/2020	Subject: (Direct Referral) Communication sponsored by Mayor Mason to apply for and accept supplementary Grant Funding from the Center for Tech and Civic Life. Recommendation: That the Mayor and City Clerk be authorized to accept supplementary funds from the Center for Tech Civic Life in the amount of \$657,000 to be used primarily for absentee ballot coordination, collection, and processing associated with the November 3rd Presidential Election. Fiscal Note: There is no City match associated with this grant funding.
0491-20	Communication	Passed	7/24/2020	8/5/2020	Subject: Communication sponsored by Alder Taft, on behalf of the City Clerk requesting to waive formal bidding and enter into an agreement with Kane Communications for community outreach and election official training revolving around the August and November Election. Recommendation of the Finance & Personnel Committee on 07-27-2020: To approve waiving formal bidding and enter into an agreement with Kane Communications for outreach revolving around the August and November Election Fiscal Note: Funds available from the Center for Tech and Civic Life Safe Elections Grant not to exceed \$1
0453-20	Communication	Passed	7/10/2020	7/21/2020	Subject: Communication co-sponsored by Alder Taft, Alder Jung, and Alder Levie providing for an advisory referendum on the November 3, 2020, election ballot to measure public opinion on whether the Wisconsin Legislature should create a nonpartisan procedure for the preparation of Legislative and Congressional district plans and maps. Recommendation of the Finance and Personnel Committee on 07-13-2020: To approve providing for an advisory referendum on the November 3, 2020, election ballot to measure public opinion on whether the Wisconsin Legislature should create a nonpartisan procedure for
0445-20	Communication	Passed	7/9/2020	8/5/2020	Subject: Communication sponsored by Alder Taft, on behalf of the City Clerk, requesting to apply and accept the Wisconsin Election Commission CARES Sub-grant to be used for August and November 2020 Election Cycle. (Grant Control #00332) Recommendation of the Finance and Personnel Committee on 07-27-2020: To approve and that the Mayor and City Clerk be authorized to apply and accept the Wisconsin Election Commission CARES Sub-grant to be used for August and November 2020 Election Cycle Fiscal Note: Amount to be determined by the Wisconsin Election Commission equal to \$200 plus \$1.10 pe
0318-20	Communication	Passed	5/29/2020	6/2/2020	Subject: (Direct Referral) Communication sponsored by Mayor Mason requesting approval to apply and accept \$100,000 in planning grant funds from the Center for Tech and Civic Life (CTCL), a 501(c)(3) nonprofit organization, for planning safe and secure election administration in the City of Racine in 2020, and coordinating such planning with other cities in Wisconsin. (Grant Control Number 00306) Recommendation of Mayor Mason: To approve applying and accepting \$100,000 in planning grant funds from the Center for Tech and Civic Life (CTCL), a 501(c)(3) nonprofit organization, for planning safe
0242-20	Communication	Passed	5/1/2020	5/5/2020	Subject: (Direct Referral) Communication from Mayor Mason, President Tate II, Alder Coe, Alder Jones, Alder Santiago, Alder Levie, Alder Horton, Alder West, Alder Jung, Alder Land, Alder Perez, Alder Taft, Alder Meekna, and Alder Lemke proposing that the Common Council direct the City Clerk to mail an application for an absentee ballot, along with a postage-paid return envelope, to all City of Racine registered voters in time for them to participate in the August 11, 2020 Partisan



City of Racine

City Hall
730 Washington Ave.
Racine, WI 53403
www.cityofracine.org

Legislative Report

File Number: Res. 0492-20

Agenda Date: 08/05/2020

File Type: Resolution

Mobile Voting Precinct

Resolved, that formal bidding, sole source, may be waived and the Mayor and City Clerk are authorized and directed to enter into an agreement with Burlington RV to purchase a mobile voting precinct.

Fiscal Note: Funds available from the Center for Tech and Civic Life Safe Elections Grant not to exceed \$250,000.00.



CENTER FOR
TECH AND
CIVIC LIFE

August 31, 2020

City of Racine

Dear Mayor Mason,

I am pleased to inform you that the Center for Tech and Civic Life ("CTCL") has decided to award you a grant to support the work of the City of Racine.

The following is a description of the grant:

AMOUNT OF GRANT: Six Hundred Fifty-Seven Thousand US Dollars (USD \$657,000).

PURPOSE: The grant funds must be used exclusively for the public purpose of planning and operationalizing safe and secure election administration in the City of Racine in accordance with the Wisconsin Safe Voting Plan 2020 and the attached "Additional Resources Requested for November 3rd, 2020 General Election."

Before we transmit these funds, we ask that you sign this agreement promising to use the grant funds in compliance with United States tax laws. Specifically, by signing this letter you agree to the following:

1. The City of Racine is a local government unit or political subdivision in the meaning of 26 USC 170(c)(1).
2. This grant shall be used *only* for the public purpose described above, and for no other purposes.
3. The City of Racine shall not use any part of this grant to give a grant to another organization unless CTCL agrees to the specific grant in writing.
4. The City of Racine has produced a plan for safe and secure election administration in 2020 and a supplement to such plan, including an assessment of election administration

needs, budget estimates for such assessment, and an assessment of the impact of the plan on voters. This supplemental plan is attached to this agreement. The City shall expend the amount of this grant for purposes contained in this plan by December 31, 2020.

5. The City of Racine shall produce a report documenting how this grant has been expended in support of the activities described in paragraph 4. This report shall be written and sent to CTCL by January 31, 2021 or in any other format approved by CTCL.
6. The City of Racine shall not reduce the budget of the City Clerk of Racine ("the Clerk") or fail to appropriate or provide previously budgeted funds to the Clerk for the term of this grant. Any amount reduced or not provided in contravention of this paragraph shall be repaid to CTCL up to the total amount of this grant.
7. CTCL may discontinue, modify, withhold part of, or ask for the return all or part of the grant funds if it determines, in its sole judgment, that (a) any of the above conditions have not been met or (b) it must do so to comply with applicable laws or regulations.
8. The grant project period of June 15, 2020 through December 31, 2020 represents the dates between which covered costs may be applied to the grant.

Your acceptance of these agreements should be indicated below. Please have an authorized representative of The City of Racine sign below, and return a scanned copy of this letter to us by email at grants@techandcivicliflife.org

On behalf of CTCL, I extend my best wishes in your work.

Sincerely,

Tiana Epps Johnson
Executive Director
Center for Tech and Civic Life

CITY OF RACINE

By: _____

Title: _____

Date: _____

Additional Resources Requested for November 3rd, 2020 General Election

- Post Office Liaison- (\$20,000)
 - A post office liaison who will be the representative to the post office regarding sending and receiving mail. This position will begin as soon as ballots are available and will assist in the day to day operations of the mail service. This will include but not limited to posting and mailing absentee ballots and election mailers, picking up the mail from the post office daily, sorting ballots, and helping to correct incomplete absentee certifications via means of the mail.
- Absentee Ballot Certification Liaison (2 positions) (\$40,000)
 - Absentee ballot contact tracers will be responsible for correcting absentee ballot certifications by making appointments to greet voters (curbside) at their house or at a designated location to witness the ballot, confirm signatures, and confirm dates are properly filled out.
 - Absentee ballot contact tracers will also make appointment with voters to meet curbside at their residence to assist voters in completing their absentee ballot they received by mail.
- Advertising for Ballot Certification Liaison to meet at your residence (\$20,000)
- 16 Extra Ballot Drop Off Boxes to be placed around the City (\$90,000)
 - This will include the cost of purchasing the drop boxes, installing the drop boxes, and security cameras
- Hazard Pay/ Overtime for City Employees to work the November 3rd Election (\$180,000)
 - This will secure enough City employees to work the Election and provide additional election officials as necessary to safely and properly complete the November Election
 - This will include overtime and hazard pay for regular City Clerk's Office Staff to preform additional duties outside of job descriptions and regular work hours
- Ballot Box Liaisons (40 positions or 2 liaisons per ballot drop off box) (\$200,000)
 - The ballot box liaisons will be responsible for attending to the ballot drop off boxes to assist voters in confirming their absentee ballot has a complete certification prior to submitting their ballot.
- Election Official Scheduler (\$25,000)
 - This position will be solely responsible scheduling all election officials, voter ambassadors, ballot box liaisons, and all other election official scheduling.
 - This position will also be responsible to track and document all hours worked for the above listed positions.
- Absentee Barcode Scanner (\$1,000)
 - We need additional scanners to help streamline the process of recording and tracking absentee ballots
- City Hall Vote Today Banner (2) (\$10,000)
 - Two large banners to hang across City Hall that will promote voting.
- Ways to Vote Mailer in English and in Spanish (\$30,000)
 - Outsource a mailer to all registered voters to provide information on the different ways to vote in both English and in Spanish.

- 10 Ipads with Hotspots (\$15,000)
 - Ipads will be used to communicate absentee ballots on Election Day that are returned to the polling location
- Secure Ballot Auxiliary Boxes (20) (\$3,000)
 - To be used on Election Day for voters to securely vote curbside
- Sign Towers (14) (\$3,000)
 - For additional sign towers to provide Spanish directions in wards that are predominantly bilingual.
- Social Distancing Supplies (\$20,000)
 - Additional social distancing supplies for Absentee Early Voting and Election Day

Total: \$657,000

UNITED STATES DISTRICT COURT
EASTERN DISTRICT OF WISCONSIN

Wisconsin Voters Alliance, et al.

Plaintiff,

v.

Civil Action No: 1:20-cv-01487

City of Racine, et al.

Defendants.

AFFIDAVIT OF KRIS TESKE

STATE OF WISCONSIN)
)SS.
COUNTY OF BROWN)

I, Kris Teske, being first duly sworn, swear and state as follows:

1. I am employed as the City Clerk by the City of Green Bay, Wisconsin (herein "City").
2. The City applied for a grant from the Center for Tech and Civic Life (herein "CTCL") in the amounts and for the purposes listed in the attached Grant Agreement and Wisconsin Safe Voting Plan (collectively "Agreement") attached hereto as Exhibit A.
3. The City received notification that it was awarded a grant by CTCL in the amount of \$1,093,400.00.
4. At its meeting on July 21, 2020, the City of Green Bay Common Council accepted award of the grant and the approved the Wisconsin Safe Voting Plan and the recommendations contained therein.

5. I have examined the Agreement, which awards CTCL grant funds to the City and sets rules for how the funds are to be spent.

6. Pursuant to the Agreement, the City must use the CTCL grant funds exclusively for the purpose of planning and operationalizing safe and secure election administration in the City in accordance with the Wisconsin Safe Voting Plan.

7. The Chief of Staff, in conjunction with other Clerk's Office, is charged with administering the CTCL grant for the City.

8. All of the CTCL grant money that has been spent, or that will be spent, has been and will be in accordance with the rules given in the Agreement.

9. None of the CTCL grant money has been or will be spent to engineer a certain election result or for a partisan purpose.

10. The CTCL grant money is being used City-wide to protect the right to vote and accommodate the safety of voters during the COVID-19 pandemic.

Dated at Green Bay, Wisconsin, this 9th day of October, 2020.

Respectfully submitted,

s/ Kris Teske
Kris Teske, City Clerk
City of Green Bay

Subscribed and sworn to before me
this 9th day of October, 2020.

s/ Electronically signed by Lindsey Belongea
Notary Public, Brown County, WI.
My Commission expires 01/17/23

UNITED STATES DISTRICT COURT
EASTERN DISTRICT OF WISCONSIN

Wisconsin Voters Alliance, et al.

Plaintiff,

v.

Civil Action No: 1:20-cv-01487

City of Racine, et al.

Defendants.

AFFIDAVIT OF DIANA ELLENBECKER

STATE OF WISCONSIN)
)SS.
COUNTY OF BROWN)

I, Diana Ellenbecker, being first duly sworn, swear and state as follows:

1. I am employed as the Finance Director for the City of Green Bay.
2. The Finance Department is charged with recording the expenditures of a \$1,093,400.00 grant the City received from the Center for Tech and Civic Life.
3. This grant's uses as of October 8, 2020 are itemized on the Grant Expenditures attached hereto as Exhibit A.
4. The City has paid \$161,850.16, has incurred but not yet paid \$931,549.84 and has \$0 remaining of this grant as of 10/9/2020.

Dated at Green Bay, Wisconsin, this 9th day of October, 2020.

Respectfully submitted,

s/ Diana Ellenbecker
Diana Ellenbecker, Finance Director
City of Green Bay

Subscribed and sworn to before me
this 9th day of October, 2020.

s/ Electronically signed by Lindsey Belongea
Notary Public, Brown County, WI.
My Commission expires 01/17/23

UNITED STATES DISTRICT COURT
EASTERN DISTRICT OF WISCONSIN

Wisconsin Voters Alliance, et al.

Plaintiff,

v,

Case No. 1:20-cv-01487-WCG

City of Racine, et al.

Defendants.

DECLARATION OF CAROL STANCATO

I, Carol Stancato, hereby declare:

1. I am employed as the Finance Director for the City of Kenosha.
2. The Finance Department is charged with recording the expenditures of a \$862,799.00 grant the City received from the Center for Tech and Civic Life ("CTCL").
3. As of the morning of October 9th, 2020 the grant's funds, paid and encumbered, as submitted to the Finance Department under the CTCL grant are recorded on the attached CTCL Expenses Spreadsheet.

I declare under penalty of perjury under the laws of the United States of America that the foregoing is true and correct.

Executed this 9th day of October, 2020.



Carol Stancato
Finance Director
City of Kenosha

UNITED STATES DISTRICT COURT
EASTERN DISTRICT OF WISCONSIN

Wisconsin Voters Alliance, et al.

Plaintiff,

v.

Case No. 1:20-cv-01487-WCG

City of Racine, et al.

Defendants.

DECLARATION OF JOHN MORRISSEY

I, John Morrissey, hereby declare:

1. I am employed as the City Administrator for the City of Kenosha, Wisconsin (herein "City").
2. The City was awarded a grant from the Center for Tech and Civic Life (herein "CTCL") in the amounts and for the purpose listed in the attached Grant Agreement and Wisconsin Safe Voting Plan (Exhibit A).
3. My Office is supervisory over the City Clerk-Treasurer's Office and the City Finance Department, and these are the primary offices tasked with expending and recording the expenditures of the CTCL grant, respectively. This declaration is made with knowledge gained from these offices and my own.
4. The City has received a grant in the amount of \$862,799.00 from CTCL.
5. I have examined Exhibit A, which awards CTCL grant funds to the City and sets the purpose guiding how the funds are to be spent.

6. Pursuant to Exhibit A, the City must use the CTCL grant funds “exclusively for the public purpose of planning and operationalizing safe and secure election administration in the City of Kenosha in accordance with the Wisconsin Safe Voting Plan.”
7. I have examined the attached CTCL Expenses Spreadsheet (Exhibit B), and believe the items recorded therein to comply with the purpose set out in Exhibit A.
8. None of the CTCL grant money will be spent to engineer a certain election result or for a partisan purpose. Future uses of the CTCL grant will be used in accordance with the purpose set out in Exhibit A.
9. The CTCL grant money is being used City-wide to protect the right to vote and accommodate the safety of voters during the COVID-19 pandemic.

I declare under penalty of perjury under the laws of the United States of America that the foregoing is true and correct.

Executed this 9th day of October, 2020.

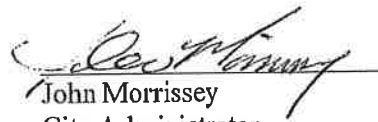
John Morrissey
City Administrator
City of Kenosha

UNITED STATES DISTRICT COURT
EASTERN DISTRICT OF WISCONSIN

Wisconsin Voters Alliance, et al.

Plaintiff,

v.

Civil Action No: 20-CV-01487

City of Racine, et al.

Defendants.

DECLARATION OF MARIBETH WITZEL-BEHL

I hereby declare, under penalty of perjury, that the information which follows below is true and correct:

1. I am employed as the City Clerk by the City of Madison, Wisconsin (herein "City"). I have held this position since 2006.
2. The City applied for a grant from the Center for Tech and Civic Life (herein "CTCL") in the amounts and for the purposes listed in the Grant Agreement and Wisconsin Safe Voting Plan (collectively "Agreement"). A copy of the signed Agreement is attached to this Declaration as Exhibit "A".
3. The City has received a grant in the amount of \$1,271,788.00 from CTCL.
4. I have examined the Agreement, which awards CTCL grant funds to the City and sets rules for how the funds are to be spent.
5. Pursuant to the Agreement, the City must use the CTCL grant funds exclusively for the purpose of planning and operationalizing safe and secure election administration in the City in accordance with the Wisconsin Safe Voting Plan.
6. My office is charged with administering the CTCL grant for the City.

7. The City has spent \$256,815.28, has incurred but not yet spent \$78,430.20, and has \$936,542.52 remaining of this grant as of October 7, 2020.

8. All of the CTCL grant money that has been spent, or that will be spent, has been and will be in accordance with the rules given in the Agreement.

9. None of the CTCL grant money has been or will be spent to engineer a certain election result or for a partisan purpose.

10. Rather, the CTCL grant money is being used City-wide to protect the right to vote and provide for the safety of voters during the COVID-19 pandemic. For example, the City of Madison is using grant funds for the following purposes: rent for polling places in the community to replace free public places unavailable due to pandemic closures, plexiglass safety screens, hand sanitizer and equipment for workers at polling places, secure ballot bags, and public advertising to encourage members of the public to have a voting plan and inform them of their options.,

11. In addition, the City has committed to spend but has not yet spent, grant monies to pay for Covid stipends as follows: \$750 to each of 92 expected polling places and \$8.17/per hour of Covid hazard pay in addition to the regular hourly wage to each of approximately 6,000 poll workers.

12. Based upon my 14 years of experience as City Clerk, my training and understanding of my duties under Wisconsin law, all of the uses to which Madison is putting the grant funds are within my authority and part of my duties pursuant to Wis. Stats. Sec. 7. 15, a copy of which is also attached to this Declaration as Exhibit "B".

Executed pursuant to 28 U.S.C. Sec. 1746 at Madison, Wisconsin, this 7th day of October, 2020.

s/ Maribeth Witzel-Behl

Maribeth Witzel-Behl, City Clerk
City of Madison

UNITED STATES DISTRICT COURT
EASTERN DISTRICT OF WISCONSIN

Wisconsin Voters Alliance, et al.

Plaintiff,

v.

Civil Action No: 20-CV-01487

City of Racine, et al.

Defendants,

DECLARATION OF S. CLAIRE WOODALL-VOGG

I, S. Claire Woodall-Vogg, hereby declare:

I make this declaration based on my personal knowledge and, if called to testify, I could and would so competently as follows.

1. I am the Executive Director of the Election Commission by the City of Milwaukee, Wisconsin (herein "City"). In my capacity as Executive Director, I administer elections for the City's voters.
2. The City applied for a grant from the Center for Tech and Civic Life (herein "CTCL") in the amounts and for the purposes listed in the attached Grant Agreement and Wisconsin Safe Voting Plan (collectively "Agreement") attached as Exhibit A.
3. The City has received a grant in the amount of \$2,154,500.00 from CTCL.
4. I have examined the Agreement, which awards CTCL grant funds to the City and sets rules for how the funds are to be spent.
5. Pursuant to the Agreement, the City must use the CTCL grant funds exclusively for the purpose of planning and operationalizing safe and secure election administration in the City in accordance with the Wisconsin Safe Voting Plan.
6. My office is charged with administering the CTCL grant for the City.

7. The City has paid \$766,560.86, has incurred but not yet paid \$1,033,000 and has \$354,939.14 remaining of this grant as of 10/8/20.
8. All of the CTCL grant money that has been spent, or that will be spent, has been and will be in accordance with the rules given in the Agreement.
9. None of the CTCL grant money has been or will be spent to engineer a certain election result or for a partisan purpose.
10. Rather, the CTCL grant money is being used City-wide to protect the right to vote and accommodate the safety of voters during the COVID-19 pandemic.

I declare under penalty of perjury under the laws of the United States of America that the foregoing is true and correct.

Executed this 8th day of October, 2020.



S. Claire Woodall-Vogg

UNITED STATES DISTRICT COURT
EASTERN DISTRICT OF WISCONSIN

Wisconsin Voters Alliance, et al.

Plaintiff,

v.

Civil Action No: 20-CV-01487

City of Racine, et al.

Defendants.

DECLARATION OF KATHLEEN FISCHER

I, Kathleen Fischer, hereby declare:

I make this declaration based on my personal knowledge and, if called to testify, I could and would do so competently as follows.

1. I am the Interim City Administrator and Assistant Finance Director for the City of Racine, Wisconsin. In such capacity, I am familiar with the finances of the City of Racine, including the receipt and use of grant funds generally as managed by the City of Racine Finance Department.
2. The Finance Department is charged with recording the expenditures of a \$942,100.00 grant the City received from the Center for Tech and Civic Life.
3. This City's use of such grant funds as of October 6, 2020, are itemized on the spreadsheet attached as Exhibit A.
4. The City has paid \$144,763.88, has incurred but not yet paid \$517,297.16, and has \$280,038.96 remaining of this grant as of October 6, 2020.

I declare under penalty of perjury under the laws of the United States of America that the foregoing is true and correct.

Executed this 7th day of October, 2020.

s/Kathleen Fischer

UNITED STATES DISTRICT COURT
EASTERN DISTRICT OF WISCONSIN

Wisconsin Voters Alliance, et al.

Plaintiff,

v.

Civil Action No: 20-CV-01487

City of Racine, et al.

Defendants.

DECLARATION OF TARA COOLIDGE

I, Tara Coolidge, hereby declare:

I make this declaration based on my personal knowledge and, if called to testify, I could and would do so competently as follows.

1. I am the City Clerk and Treasury Manager for the City of Racine, Wisconsin. In my capacity as City Clerk I administer elections for the City's voters.
2. The City of Racine applied for a grant from the Center for Tech and Civic Life (herein "CTCL") in the amounts and for the purposes listed the Grant Agreement and Wisconsin Safe Voting Plan (collectively "Agreement") attached as Exhibit A.
3. The City received a grant in the amount of \$942,100.00 from CTCL. The City of Racine Common Council unanimously approved acceptance of the grant on July 8, 2020.
4. I have examined the Agreement, which awards CTCL grant funds to the City and sets rules for how the funds are to be spent.
5. Pursuant to the Agreement, the City must use the CTCL grant funds exclusively for the purpose of planning and operationalizing safe and secure election administration in the City in accordance with the Wisconsin Safe Voting Plan.

6. My office is charged with administering the CTCL grant for the City.

7. The City has paid \$144,763.88, has incurred but not yet paid \$517,297.16, and has \$280,038.96 remaining of this grant as of October 6, 2020.

8. All of the CTCL grant money that has been spent, or that will be spent, has been and will be in accordance with the rules stated in the Agreement.

9. None of the CTCL grant money has been or will be spent to engineer a certain election result or for a partisan purpose.

10. Rather, the CTCL grant money is being used City-wide to protect the right to vote and accommodate the safety of voters during the COVID-19 pandemic.

I declare under penalty of perjury under the laws of the United States of America that the foregoing is true and correct.

Executed this 7th day of October, 2020.

s/Tara Coolidge



CENTER FOR
TECH AND
CIVIC LIFE

August 3, 2020

City of Racine

Dear Mayor Mason,

I am pleased to inform you that the Center for Tech and Civic Life ("CTCL") has decided to award a grant to support the work of the City of Racine.

The following is a description of the grant:

AMOUNT OF GRANT: Nine hundred, forty-two thousand, one hundred US dollars (USD \$942,100.00).

PURPOSE: The grant funds must be used exclusively for the public purpose of planning and operationalizing safe and secure election administration in the City of Racine in accordance with the Wisconsin Safe Voting Plan 2020 ("Appendix").

Before we transmit these funds, we ask that you sign this agreement promising to use the grant funds in compliance with United States tax laws. Specifically, by signing this letter you agree to the following:

1. The City of Racine is a U.S., state, or local government unit or political subdivision in the meaning of 26 USC 170(c)(1).

Exhibit A

2. This grant shall be used *only* for the public purpose described above, and for no other purposes.
3. The City of Racine shall not use any part of this grant to give a grant to another organization unless CTCL agrees to the specific sub-recipient in advance, in writing.
4. The City of Racine has produced a plan for safe and secure election administration in 2020, including an assessment of election administration needs, budget estimates for such assessment, and an assessment of the impact of the plan on voters. This plan is attached to this agreement as an Appendix. The City shall expend the amount of this grant for purposes contained in this plan by December 31, 2020.
5. This grant is intended to support and shall be used solely to fund the activities and purposes described in the plan produced pursuant to paragraph 4.
6. The City of Racine shall produce a report documenting how this grant has been expended in support of the Appendix. This report shall be provided to CTCL by January 31, 2021.
7. The City of Racine shall not reduce or otherwise modify planned municipal spending on 2020 elections, including the budget of the City Clerk of Racine ("the Clerk") or fail to appropriate or provide previously budgeted funds to the Clerk for the term of this grant. Any amount reduced or not provided in contravention of this paragraph shall be repaid to CTCL up to the total amount of this grant.
8. CTCL may discontinue, modify, withhold part of, or ask for the return of all or part of the grant funds if it determines, in its sole judgment, that (a) any of the above conditions have not been met or (b) it must do so to comply with applicable laws or regulations.
9. The grant project period of June 15, 2020 through December 31, 2020 represents the dates between which covered costs may be applied to the grant.

Your acceptance of these agreements should be indicated below. Please have an authorized representative of The City of Racine sign below, and return a scanned copy of this letter to us by email at grants@techandcivicliflife.org

On behalf of CTCL, I extend my best wishes in your work.

Sincerely,

Tiana Epps Johnson
Executive Director
Center for Tech and Civic Life

Accepted on behalf of the City of Racine:

SEE ATTACHMENT

By: _____

Title: _____

Date: _____

APPENDIX: Wisconsin Safe Voting Plan 2020 Submitted to the Center for Tech & Civic Life
June 15, 2020

CENTER FOR TECH & CIVIC LIFE
HELLO@TECHANDCIVICLIFE.ORG

PAGE 3

CITY OF RACINE

By: Cory Mason 8/6/2020
Cory Mason, Mayor Date

ATTEST:

By: Tara Coolidge 8/6/2020
Tara Coolidge, City Clerk Date

Provisions have been made to pay the liability that will accrue hereunder.

By: David Brown 8-6-20
David Brown, Finance Director Date

APPROVED AS TO FORM:

By: Scott R. Letteney August 6 2020
Scott R. Letteney, City Attorney Date



**Wisconsin Safe Voting Plan 2020
Submitted to the Center for Tech & Civic Life
June 15, 2020**

The State of Wisconsin found itself in the midst of an historic election in April of 2020 when statewide elections occurred in the midst of the COVID-19 pandemic. These elections included not only the presidential preference vote, but also local races for city councils, county boards, school board, and mayors, a statewide election for a seat on the Wisconsin Supreme Court, and numerous district-wide school referenda.

Municipalities were required to make rapid and frequent adjustments to ensure compliance with the rapidly changing Supreme Court, Wisconsin Supreme Court, and Wisconsin Election Commission (WEC) rulings about the election. (The April 2020 Election may go down in history as the only election in which the Wisconsin Supreme Court and the US Supreme Court weighed in on the same day on how the election would be conducted.)

The shifting legal landscape was also complicated by the extraordinary lengths municipal clerks went to to ensure that both voting and election administration were done in accordance with prevailing public health requirements.

As mayors in Wisconsin's five biggest cities - Milwaukee, Madison, Green Bay, Kenosha, and Racine - we seek to work collaboratively on the two remaining 2020 elections (August 11th and November 3rd) to: safely administer elections to reduce the risk of exposure to coronavirus for our residents as well as our election officials and poll workers; identify best practices; innovate to efficiently and effectively educate our residents about how to exercise their right to vote; be intentional and strategic in reaching our historically disenfranchised residents and communities; and, above all, ensure the right to vote in our dense and diverse communities.

Table 1: Summary of Municipalities' Electorate Data, June 2020

	Green Bay	Kenosha	Madison	Milwaukee	Racine
Estimated Eligible Voters	71,661	73,000	213,725	430,000	56,000
Registered Voters	52,064	47,433	178,346	294,459	34,734
2020 Election Budget	\$329,820	\$205,690	\$2,080,283	\$2,986,810	\$409,529

All five jurisdictions share concerns about how to best facilitate voter participation and limit exposure to coronavirus. All five jurisdictions spent all or most of the budgeted resources for all of 2020 on the extraordinary circumstances this Spring. If no plan is approved, it will leave communities like ours with no choice but to make tough decisions between health and the right to vote; between budget constraints and access to fundamental rights. The time that remains between now and the November Election provides an opportunity to plan for the highest possible voter turnouts in the safest possible ways.

We are collectively requesting a total of \$6,324,527 as summarized in Table 3 below and detailed extensively in the plan.

Review of the April 2020 Election

The April 2020 election placed two sacred duties of cities in conflict: keeping our residents safe and administering free and fair elections. Since Wisconsin's elections are administered at the municipal level, each municipality was on its own to deal with these dynamics. Our Municipal Clerks and their staff are all remarkable public servants, who responded nimbly and effectively to marshal the resources needed to run these elections under exceedingly challenging circumstances. In this election, all five of our municipalities faced:

- Precipitous drop-offs of experienced poll workers
- A scramble to procure enough PPE to keep polling locations clean and disinfected and to mitigate COVID-19 risk for election officials, poll workers, and voters;
- A never-before-seen increase in absentee ballot requests;
- High numbers of voters who struggled to properly submit required photo ID and/or provided insufficient certification of absentee ballot envelopes; and
- Voters who, understandably, were completely confused about the timeline and rules for voting in the midst of a pandemic and required considerable public outreach and individual hand-holding to ensure their right to vote.

See Table 2, below, for detailed data on all five municipalities' April 2020 absentee mail and in-person early voting experiences.

Table 2: Summary of Municipalities' Experiences in April 2020 Election

	Green Bay	Kenosha	Madison	Milwaukee	Racine
# of voters who requested absentee ballots for April election	15,509	16,017	89,730	96,712	11,615
# of absentee ballots successfully cast in April	11,928	13,144	77,677	76,362	9,570
# of absentee ballot requests unfulfilled due to insufficient photo ID	Unknown	Unknown	1,840	2.5%	Estimated hundreds
# of absentee ballots rejected due to incomplete certification	312	196	618	1,671	368
# of secure drop-boxes for absentee ballot return	1	2	3	5	1
# of days of early voting	12	10	19	14	13
Use curbside voting for early voting?	✓	✗	✓	✓	✓
# of voters who voted in-person early absentee	778	85	4,930	11,612	1,543
# of additional staff enlisted for election-related efforts	85	60	225	95	20
\$ spent on PPE	\$2,122	\$13,000	\$6,305	Unknown	Unknown
# of polling locations	2	10	66	5	14
Use drive-thru or curbside voting on Election Day?	✓	✗	✓	✓	✓

Comprehensive Election Administration Needs for 2020

In early June 2020, all five municipal clerks and their staff, with review and support from all five cities' Mayors and Mayoral staff, completed a detailed, multi-page template (attached) providing both data and information about the municipalities' election plans and needs. This Wisconsin Safe Voting Plan 2020 is based on that comprehensive information. All five of our municipalities recommend the following four strategies to ensure safe, fair, inclusive, secure, and professional elections in our communities for the remaining 2020 elections:

Recommendation I: Encourage and Increase Absentee Voting (By Mail and Early, In-Person)

1. Provide assistance to help voters comply with absentee ballot requests & certification requirements
2. Utilize secure drop-boxes to facilitate return of absentee ballots
3. Deploy additional staff and/or technology improvements to expedite & improve accuracy of absentee ballot processing
4. Expand In-Person Early Voting (Including Curbside Voting)

Recommendation II: Dramatically Expand Strategic Voter Education & Outreach Efforts, Particularly to Historically Disenfranchised Residents

Recommendation III: Launch Poll Worker Recruitment, Training & Safety Efforts

Recommendation IV: Ensure Safe & Efficient Election Day Administration

As detailed in this plan, our municipalities are requesting a total of \$6,324,567 to robustly, swiftly, comprehensively, and creatively implement these four strategic recommendations in each of our communities. That request is summarized as follows in Table 3, below, and detailed extensively in the remainder of this plan.

Table 3: Summary of Resources Needed to Robustly Implement All Four Recommendations

Recommendation	Green Bay	Kenosha	Madison	Milwaukee	Racine	Totals
Encourage and Increase Absentee Voting By Mail and Early, In-Person	\$277,000	\$455,239	\$548,500	\$998,500	\$293,600	\$2,572,839
Dramatically Expand Strategic Voter Education & Outreach Efforts	\$215,000	\$58,000	\$175,000	\$280,000	\$337,000	\$1,065,000
Launch Poll Worker Recruitment, Training & Safety Efforts	\$174,900	\$145,840	\$507,788	\$800,000	\$181,500	\$1,810,028
Ensure Safe & Efficient Election Day Administration	\$426,500	\$203,700	\$40,500	\$76,000	\$130,000	\$876,700
Totals:	\$1,093,400	\$862,779	\$1,271,788	\$2,154,500	\$942,100	\$6,324,567

Recommendation I: Encourage & Increase Absentee Voting By Mail and Early In-Person

Of all the things that need to be done to ensure access and safety at the polls, this is perhaps the most important and timely. It is time, resource, and labor intensive but results in the voter being able to vote by mail or from the relative safety of their car or at a socially distanced and carefully planned early voting site.

Overview of Absentee Voting in Wisconsin

Before discussing our strategies and plans to encourage and increase absentee voting, both by mail and in-person, early voting, it's important to first understand the absentee voting context in Wisconsin.

There are two ways to vote early in Wisconsin: in-person and through the mail. Both are technically called "absentee voting," a phrase held over from a time when absentee voting required you to affirm that you were over 80, ill, or going to be out of the municipality on Election Day. Those requirements no longer exist in the statutes, and people can vote early, or absentee, for any reason. The April 2020 election saw dramatic increases in the number of absentee ballot requests over previous elections.

While for many regular voters, absentee voting - whether completed by mail or early, in-person - is a relatively easy process, our five cities understand that absentee voting does not work easily for all voters. Our communities of color, senior voters, low-income voters without reliable access to the internet, people with disabilities, and students all have legitimate concerns about the absentee voting process.

Voting absentee by mail has been complicated by the fairly recent imposition of state law requiring voters to provide an image of their valid photo ID prior to first requesting an absentee ballot. While this works relatively easily for voters who have valid photo IDs and the technology necessary to upload an image file of that valid ID into the state's myvote.wi.gov website, it does not work well or easily for other voters who do not have valid photo ID (complicated by closure of DMVs due to the pandemic), lack access to reliable internet (also complicated by coronavirus-related closures or reduced hours at libraries and community centers, leaving those residents without regular public internet access that our municipalities normally provide), those who don't have smart phones to take and upload photos, and those who need additional education about what constitutes a valid photo ID. (For example, countless voters in our municipalities attempted to submit "selfies" as valid photo ID. Explaining to them that this was not a valid form of photo ID and instructing them on how to properly submit valid ID took considerable staff time and resources.)

Once the absentee ballot is received, it must be completed correctly to be successfully cast, and there are numerous certification requirements on the absentee ballot envelope; if not correctly completed, the ballot could be rejected. Prior to this April's

election very small numbers of voters had traditionally chosen to cast ballots by mail. Municipal clerks' offices simply were not prepared and do not have the staffing or technological resources needed to quickly process dramatically higher numbers of absentee ballot requests, troubleshoot problems, answer voter questions, provide information and to expedite the processing of thousands of received absentee ballots on Election Day.

In-person early absentee voting also poses challenges for voters and election administrators. While all of our communities had previously offered early voting locations and hours, April's election required election officials to creatively and quickly expand in-person early voting opportunities, including curbside voting, all while prioritizing necessary COVID-19 precautions.

As indicated by Table 4, below, all five of our municipalities are already experiencing dramatic increases in the number of voters requesting to vote absentee, compared to pre-pandemic, and must procure resources to enable voters in our communities to meaningfully access absentee voting.

Table 4: Absentee Ballots in All Municipalities as of June 2020

	Green Bay	Kenosha	Madison	Milwaukee	Racine
# of voters on permanent absentee list prior to 2/18/20	1,628	1,856	2,062	6,252	613
# of voters on permanent absentee list as of 4/7/20	4,306	3,469	8,665	23,374	2,684
# of voters who have already requested absentee ballots for August 2020	5,162	9,450	36,092	53,438	3,389
# of voters who have already requested absentee ballots for November 2020	4,859	9,123	34,164	50,446	3,204

We are committed to making voting accessible via mail, in-person prior to Election Day, and at the polls on Election Day. Particularly in the midst of a global pandemic when many voters are rightfully apprehensive about in-person voting, we want to ensure that voters in our communities know they have options and we are committed to conducting the necessary voter outreach and education to promote absentee voting and encourage higher percentages of our electors to vote absentee.

Increasing the number of voters who cast votes prior to Election Day minimizes the risk of spreading COVID-19 on Election Day from in-person contacts at our polling locations, and it reduces the chance for lines and delays in voting on Election Day.

The Wisconsin Election Commission (WEC) has approved a proposal to mail all registered voters absentee ballot request forms, which allows our five communities to focus on helping voters overcome the barriers to successfully returning those forms so they can obtain, and then successfully submit, their completed absentee ballots. This measure will provide absentee request information directly to voters, alleviating the need for municipalities to expend the cost to send the mailing. However, it is unclear how this measure will affect the workload of municipal clerks. Although the WEC has directed that the forms be returned to the WEC for entry, municipal clerks must still review each record, process, mail, record receipt and canvass each absentee ballot.

All of our municipalities anticipate continued large increases in absentee voting based on the April 2020 trends. Milwaukee, for example, anticipates that 80% of residents will vote absentee by mail for both the August primary and the November general election.

All five cities have identified numerous barriers to successful absentee voting, including: voters facing numerous challenges to successfully submitting valid photo ID; voters needing assistance complying with absentee ballot certification requirements, including obtaining the required witness signature on the absentee ballot return envelope; the labor-intensive process faced by all of our clerks' offices of processing absentee ballot requests; and U.S. Postal Service errors and mail delays. All of these are challenges for our municipalities in normal elections, but they are all compounded by the coronavirus pandemic, and made exponentially more difficult by the unprecedented volume of absentee voting requests. This puts tremendous strain on municipal election clerks and their staff.

Our five cities share the desire to assist as many residents as possible with casting ballots before Election Day, serving as the greatest opportunity we have to mitigate the spread of COVID-19 in our communities. We have identified several strategies to help voters in each of our communities overcome these barriers to successful absentee voting, both by mail and in-person early voting.

Overall, our five communities are requesting **\$2,572,839** in resources related to enabling our municipalities to overcome these particular barriers and ensure that our voters can meaningfully access absentee voting, both by mail and in-person early voting. These strategies and resource needs are broken down into four distinct component recommendations, within the overall umbrella of increasing and encouraging absentee voting:

1. **Provide assistance to help voters comply with absentee ballot requests & certification requirements**

- **Green Bay:** The City would like to employ bilingual LTE "voter navigators" (\$45,000) to help residents properly upload valid photo ID, complete their ballots and comply with certification requirements, and offer witness signatures. These voter navigators can assist voters prior to the elections and then also be trained and utilized as election inspectors. They would also like to utilize paid social media and local print and radio advertising to educate and direct voters in how to upload photo ID and how to request and complete absentee ballots. (\$2,000)
Total: \$47,000
- **Kenosha:** The City would like to have Clerk's staff train library staff on how to help residents request and complete absentee ballots, would like to produce (\$3,000) and mail (\$26,200) a bilingual absentee ballot instruction sheet with all absentee ballots to increase correctly completed and submitted ballots. The City would like to hire a trainer for seasonal election workers, volunteers and poll workers. This employee would also coordinate assignments to polling locations, the early driver up voting site, the Clerk's office for assistance in processing, data entry and filing of absentee requests and the Absentee Board of Canvassers (approximately \$50,000). The increase in absentee ballots due to COVID-19 has tremendously increased the workload of the department. In order to properly serve the citizens and voters additional LTE employees are needed (approximately \$175,000). **Total: \$254,200**
- **Madison:** Plans to hold curbside "Get your ID on File" events with the Clerk this summer utilizing volunteers or paid poll workers (\$15,000) equipped with PPE (estimated \$5,000) and digital cameras (\$4,500) to capture voter ID images for voters who are unable to electronically submit their IDs to the Clerk's office. They also need large flags to draw attention to these curbside sites (\$4,000). Would also like mobile wifi hotspots and tablets for all of these sites (\$100,000) so voters could complete their voter registration and absentee requests all at once, without having to wait for staff in the Clerk's office to follow up on paper forms. (These mobile wifi hotspots, tablets, and flags, could all then be repurposed for early in-person voting closer to the election.) **Total: \$128,500**
- **Milwaukee:** The City notes that the biggest obstacle to Milwaukee residents, particularly those in poverty, to applying for an absentee ballot in April was access to the internet and securing an image of their photo ID. To address this, the City will be promoting and utilizing Milwaukee Public Library branch staff (\$90,000 for both elections) for 3 weeks prior to each election to assist any potential absentee voters with applying, securing, and uploading images of their valid photo ID. **Total: \$90,000**
- **Racine:** The City will recruit and promote (\$1,000), train (\$3,000), and employ paid Voter Ambassadors (\$8,000) who will be provided with both PPE and

supplies (\$4,000) and set up at the City's community centers to assist voters with all aspects of absentee ballot request, including photo ID compliance. Due to the increase of absentee mailed requests the City of Racine will need an additional 2 full time staff members in the Clerk's Office in order to have a reasonable turn-around time for absentee requests (\$100,000). Total: **\$116,000**.

Total: \$635,700

2. Utilize Secure Drop-Boxes to Facilitate Return of Absentee Ballots

Our five communities all share a desire to expand voters' ability to easily return absentee ballots to the municipality without having to rely on the postal service, since, after April's election, many voters are (rightfully) apprehensive that putting their completed ballot in the mail does not guarantee it will be received and counted by the municipality by statutory deadlines. Voters also need to have confidence that they are returning their completed absentee ballots into secure containers that are not at risk of tampering. All five cities need resources to purchase additional secure drop-boxes and place them at key locations throughout their cities, including libraries, community centers, and other well-known places, to ensure that returning completed ballots is as secure and accessible to voters throughout our cities as possible.

- **Green Bay:** The City would like to add secure (security cameras \$15,000) ballot drop-boxes (approximately \$900 each) at a minimum of the transit center and two fire stations, but if funding were available would also install secure drop boxes at Green Bay's libraries, police community buildings, and potentially several other sites including major grocery stores, gas stations, University of Wisconsin Green Bay, and Northern Wisconsin Technical College, in addition to the one already in use at City Hall. **Total: \$50,000**
- **Kenosha:** The City currently has two drop-boxes that are checked throughout the day, and would like to install 4 additional internal security boxes at Kenosha libraries and the Kenosha Water Utility so that each side of town has easy access to ballot drop-boxes. **Total: \$40,000**
- **Madison:** The City would like to have one secure drop box for every 15,000 voters, or 12 drop boxes total (\$36,000). The City would also like to provide a potential absentee ballot witness at each drop box, utilizing social distancing and equipped with PPE (staff costs unknown): **Total: \$50,000**
- **Milwaukee:** The City would like to install secure 24-hour drop boxes at all 13 Milwaukee Public library branches, staffed with socially distanced volunteers to serve as witnesses. **Total: \$58,500**

- **Racine:** The City currently has one secured drop box for absentee ballots, and would like to have 3 additional drop boxes, each equipped with security cameras, to install at key locations around the City. **Total: \$18,000.**

Total: \$216,500

3. Deploy Additional Staff and/or Technology Improvements to Expedite & Improve Accuracy of Absentee Ballot Processing

The process of assembling and mailing absentee ballots is labor-intensive, slow, and subject to human error. Absentee ballot requests must be approved and entered into the statewide system, labels must be printed and applied to envelopes, ballots must be initialed, folded, and inserted into the envelope along with instructions. Ballots must be logged when received back from the voter. Undeliverable ballots must be reviewed, reissued or canceled. When voters make mistakes on ballots the requests to reissue must be completed. These tasks are time-consuming and utilizing existing clerk's office staff pulls them away from all of the other service requests, phone answering, and tasks handled by busy municipal clerks' offices.

The tremendous increase in absentee ballot requests in April was unprecedented, and municipal clerks and their staff were unprepared for the volume. They responded remarkably well - particularly since many of their staff were, by late March and early April, working remotely or, at a minimum, all needing to adhere to social distancing and masking precautions when working together in the same room - but all five municipalities need additional resources to accurately and swiftly process absentee ballot requests.

- **Green Bay:** The City needs 45 additional staff to process absentee ballot requests before the election, to open and verify envelopes on Election Day, and insert them into the tabulators. After the election, staff are needed to enter new voter registrations and assist with all election certification tasks (\$140,000 for staffing) The City would also like to purchase a ballot opener and ballot folder to expedite processing (\$5,000). **Total: \$145,000.**
- **Kenosha:** The City needs resources for absentee ballot processing, to staff and process early, in-person absentee requests, and to answer voters' questions (approximately \$100,000). Additional workers are also needed to canvass absentee ballots (approximately \$11,000) **Total: \$111,000**
- **Madison:** Based on data from April, the City estimates it will need additional staffing (\$110,000) for hourly election clerks for the fall elections, and will incur

additional overtime costs (\$100,000) for staff processing of absentee ballots and other election-related tasks. **Total: \$210,000**

- **Milwaukee:** Given its tremendous volume of absentee ballot requests and processing tasks which far exceeds that of the other municipalities, Milwaukee would like to completely automate and expedite the assembly and mailing of requested absentee ballots. The City would like to purchase a high-speed, duplex printer, a top-of-the-line folding machine, and a high quality folding and inserting machine. This would reduce staff costs and eliminate the use of absentee labels, by enabling the City to print directly onto inner and outer envelopes. This would also allow the City to have a small 2D barcode that the inserter machine would be able to scan to ensure that the outer envelope is for the same voter; increasing quality controls. This automation would enable the City to eliminate the assembly delay no matter the volume of daily absentee requests, allowing experienced election workers and previously trained election temporary employees to be re-deployed to early voting sites as supervisors and lead workers. **Total: \$145,000**
- **Racine:** To process absentee ballot requests in April, the City estimates that it will need seven additional full-time employees to process fall election requests. These employees will be needed full-time for one month prior to the August Election (approximately \$17,000) and seven weeks prior to the November election (approximately \$30,000). **Total: \$47,000**

Total: \$668,000

4. Expand In-Person Early Voting (Including Curbside Voting)

For a variety of reasons, many voters in our municipalities do not want to vote by mail and prefer to vote in-person. As a result of the coronavirus, far more voters are interested in early, in-person absentee voting (EIPAV) than we've seen in previous elections, wishing to avoid lines or crowds on Election Day. All five municipalities would like to have resources to accommodate these early, in-person voters. Expanding access to early, in-person voting also will lessen lines at polling places on Election Day and allow for proper social distancing and other pandemic precautions to be uniformly implemented.

Curbside and drive-thru voting have been very popular with residents of our municipalities, particularly for those with health concerns who can remain in the cars and have a virtually contact-less voting process. For example, Milwaukee previously operated in-person early voting for one week leading up to the April election at three sites and then transitioned to one site of drive-thru voting. 11,612 cast ballots through these options: 5,571 via in-person and 6,041 at drive-thru, and these numbers represent a 46% increase over April 2016 "early voting" totals. However, it is slow-moving and

labor-intensive. Additionally, particularly in the larger cities among us, it requires law enforcement and traffic control assistance to help manage traffic.

- **Green Bay:** The City would like to expand and establish at least three EIPAV sites in trusted locations, ideally on the east (potentially UWGB) and west sides (potentially NWTC or an Oneida Nation facility) of the City, as well as at City Hall. The City is planning to offer early voting starting two weeks before each election, with several weekdays available until 8.30pm and Saturdays 10am-4pm. They would like to staff these early voting sites with election inspectors who are bilingual and would like to increase the salary rate for these bilingual election inspectors to assist with recruitment and retention, as well as in recognition of their important role at these sites. The City also will need to print additional ballots, signage, and materials to have available at these early voting sites. **Total: \$35,000.**
- **Kenosha:** The City plans to have one early voting location, at City Hall, and plans to hold early voting two weeks before the August election, with no weekend or evening hours planned, and 4 weeks before the November election, with access until 7pm two days/week and Saturday voting availability the week before the election. If City Hall is still closed to the public, they will explore offering early drive thru voting on City Hall property. Resources are needed for staffing (approximately \$40,000), PPE (\$1,050), signage (\$200), laptops, printers, and purchase of a large tent (\$8,789) to utilize for drive thru early voting. Staff could see voters' ID, print their label, hand them their ballot, and then collect the completed envelope. This would also allow staff to help voters properly do certification and provide witness signatures if necessary. The City could do this for one full week before elections. **Total \$50,039.**
- **Madison:** The City would like to provide 18 in-person absentee voting locations for the two weeks leading up to the August election, and for the four weeks leading up to the November election. Their original plan was to offer in-person absentee voting at all nine library locations, the City Clerk's Office, a city garage, Edgewood College, two Madison College locations, and four UW-Madison locations. Due to weather uncertainties, they will need to purchase and utilize tents (\$100,000) for the curbside voting locations in order to protect the ballots, staff, and equipment from getting wet and will also need large feather flags to identify the curbside voting sites. (Additional staff costs covered by the earlier question re. Absentee ballot processing.) The City would also like to get carts (\$60,000) for our ExpressVote accessible ballot marking devices so we can use the ExpressVote for curbside voting to normalize the use of ExpressVote to help voters with disabilities feel less segregated during the voting process. **Total: \$160,000.**
- **Milwaukee:** The City would like to set up 3 in-person early voting locations for two weeks prior to the August election (\$150,000) and 15 in-person early voting

locations and 1 drive-thru location, potentially at a central location like Miller Park, for four weeks prior to the November election (\$450,000). (Establishing this many EIPAV sites requires a significant investment in IT equipment, an additional ballot printer, tents, signage, and traffic control assistance. Milwaukee would also like to offer evening and weekend early voting hours which would add additional costs for both August (\$30,000) and November (\$75,000). **Total: \$705,000.**

- **Racine:** The City would like to offer a total of 3 EIPAV satellite locations for one week prior to the August election, as well as offering in-person early voting - curbside, if City Hall is still closed to the public - at the Clerk's office for 2 weeks prior to the August election. For the November election, Racine would like to offer EIPAV at 4 satellite locations two weeks prior to the election and at the Clerk's office (again, potentially curbside) 6 weeks prior. The City would need to obtain PPE, tents, supplies and cover staff time and training (\$40,000). Racine would also like to have all satellite locations available for half-day voting the two Saturdays (\$17,000) and Sundays (\$17,000) prior to the November election, and the library and mall locations would be open until 8pm the week prior to the Election. Additional resources needed include one-time set-up fee per location (\$7,500), laptops and dymo printers (\$10,000), training (\$1,100), and signage (\$12,000.) As well, the City would like to host at least one drive-thru Voter Registration Day, where City Hall would be set up for residents to come get registered, curbside, and get their voting questions answered by Clerk's staff. Newly registered voters could also get assistance requesting absentee ballots for upcoming elections while they're there. (\$8,000) **Total: \$112,600**

Total: \$1,062,639.00

Recommendation I Total for All Strategies to Encourage and Increase Absentee Voting by Mail and Early, In-Person: \$2,572,839.00

Recommendation II: Dramatically Expand Voter & Community Education & Outreach, Particularly to Historically Disenfranchised Residents

All five municipalities expressed strong and clear needs for resources to conduct voter outreach and education to their communities, with a particular emphasis on reaching voters of color, low-income voters without reliable access to internet, voters with disabilities, and voters whose primary language is not English. This outreach is particularly necessary given the voter confusion that ensued in the lead-up to the April election, and voters' concerns and questions about voting during the COVID-19 pandemic. We understand that our communities of color do not necessarily trust the voting process, and that we need to work to earn that trust. We want to be transparent and open about what happens behind the scenes in elections, and what options are available for casting a ballot. We also want to make sure we are listening to groups that have historically been disenfranchised and groups that are facing obstacles with voting during this pandemic, and working with them to effectively respond to their concerns.

Voter outreach and education is also needed to encourage and explain new voter registration, and to encourage voters to verify and update their address or other voter registration information to do so prior to the Election. None of our communities have sufficient resources budgeted or available for the strategic, intentional, and creative outreach and education efforts that are needed in our communities over the summer and into the fall.

We all want our communities to have certainty about how the voting process works, trust in our election administration's accuracy, and current, accurate information on what options are available to vote safely in the midst of the pandemic. Significant resources are needed for all five municipalities to engage in robust and intentional voter education efforts to reduce confusion; encourage and facilitate new voter registration and registration updates; provide clear, accessible, and accurate information; address voters' understandable pandemic-related safety concerns; reassure voters of the security of our election administration; and, ultimately, reduce ballot errors and lost votes and enhance our residents' trust and confidence in our electoral process.

- **Green Bay:** Would like to reach voters and potential voters through a multi-prong strategy utilizing "every door direct mail," targeted mail, geo-fencing, billboards, radio, television, and streaming-service PSAs, digital advertising, and automated calls and texts (\$100,000 total). The City would also like to ensure that these efforts can be done in English, Spanish, Hmong, and Somali, since roughly 11% of households in the Green Bay area speak a language other than English. Ideally, the City would employ limited term communications staff or engage communications consultants (\$50,000) from August through the November election to design these communications and design and launch paid advertising on Facebook, Twitter, and Instagram, also in multiple languages. The City would also like to directly mail to residents who are believed to be eligible but not registered voters, approximately 20,000 residents. It would require both

considerable staff time to construct that list of residents and directly mail a professionally-designed piece (in multiple languages) to those voters. (\$50,000 total for staffing, design, printing, and postage). To assist new voters, the City would also like resources to help residents obtain required documents (i.e. birth certificates) which are needed to get a valid state ID needed for voting. These grant funds (\$15,000) would be distributed in partnership with key community organizations including churches, educational institutions, and organizations serving African immigrants, LatinX residents, and African Americans.

Total: \$215,000

- **Kenosha:** Would like to directly communicate to all Kenosha residents via professionally-designed targeted mail postcards that include information about the voter's polling location, how to register to vote, how to request an absentee ballot, and how to obtain additional information. The City would have these designed by a graphic designer, printed, and mailed (\$34,000). The City would also like resources for social media advertising, including on online media like Hulu, Spotify, and Pandora (\$10,000) and for targeted radio and print advertising (\$6,000) and large graphic posters (\$3,000) to display in low-income neighborhoods, on City buses, and at bus stations, and at libraries (\$5,000).
Total: \$58,000
- **Madison:** Would like to engage the City's media team to produce videos to introduce voters to the election process, voting options, and to explain the safety precautions taken at polls and early voting sites. These videos would then be shared in numerous ways, including through partner organizations and on the City's social media platforms. The City would also like to partner with community organizations and run ads on local Spanish-language radio, in the Spanish-language newspapers, on local hip hop radio stations, in African American-focused printed publications, and in online publications run by and for our communities of color (advertising total \$100,000). Additionally, the City has many poll workers who are from historically disenfranchised communities. The City would like to pay those poll workers (\$75,000) to conduct voter outreach and additional poll worker recruitment activities. **Total: \$175,000.**
- **Milwaukee:** Would like to partner with other City divisions to develop mailings and door hangers (\$10,000) that could accompany water bills, be distributed by the Department of Neighborhood Services, or hung on trash receptacles by sanitation staff. The City would also like to revamp current absentee voting instructions to be more visual, address issues specific to the pandemic such as securing a witness signature, prepare it in English and Spanish, and print 150,000 color copies (estimated total \$15,000). The Election Commission would also like to produce a short video (\$5,000) with visuals showing voters how to apply for an absentee ballot and how to correctly complete and return the ballot. Additionally, the Election Commission would like to hire a communications firm to prepare and implement a comprehensive voter outreach communications plan

(\$250,000). This communications effort would include numerous voter education ads and PSAs on radio, billboards, buses, with some using local celebrities like Milwaukee Bucks players. This communications effort would focus on appealing to a variety of communities within Milwaukee, including historically underrepresented communities such as LatinX and African Americans, and would include a specific focus on the re-enfranchisement of voters who are no longer on probation or parole for a felony. Additionally, this campaign would include an edgy but nonpartisan and tasteful communications campaign to harness the current protests' emphasis on inequity and ties that message to voting. The video, the ads, and the PSAs could all also be placed on social media, the Election Commission and City websites, and GOTV partner websites and social media. **Total: \$280,000**

- **Racine:** The City would like to retain a communications firm to design and implement a comprehensive voter outreach communications plan (\$80,000). This would include ads on Facebook, Instagram, and Snapchat. The City would also like to rent billboards in key parts of the City (\$5,000) to place messages in Spanish to reach Spanish-speaking voters. The City would also like to do targeted outreach aimed at City residents with criminal records to encourage them to see if they are not eligible to vote; this outreach will be accomplished with the production, editing, and sharing of a YouTube video (\$2,000) specifically on this topic shared on the City's website, social media channels, and through community partners. Racine would also like to purchase a Mobile Voting Precinct so the City can travel around the City to community centers and strategically chosen partner locations and enable people to vote in this accessible (ADA-compliant), secure, and completely portable polling booth on wheels, an investment that the City will be able to use for years to come. (Estimated cost \$250,000). **Total: \$337,000**

Recommendation II Total For All Strategies to Dramatically Expand Strategic Voter Education and Outreach Efforts, Particularly to Historically Disenfranchised Residents: \$1,065,000.00

Recommendation III: Launch Poll Worker Recruitment, Training, and Safety Efforts

The pandemic made conducting Election Day activities extremely challenging. Most poll workers in Wisconsin are retirees doing their civic duty to help facilitate the election. Given the increased risk for the elderly if exposed to COVID-19, many experienced poll workers opted out. Milwaukee had so many poll workers decline to serve that the City went from 180 polling locations to five polling locations. Green Bay, facing a similar exodus of poll workers, went down to two polling locations. Racine usually relies on nearly 190 poll workers for a spring election; only 25 of those experienced poll workers were under the age of 60.

As fears about the coronavirus increased in mid-late March and early April, poll workers in all five municipalities declined to work the election, leaving cities scrambling to quickly recruit enough bodies to keep polling locations open. All cities were appreciative of the last minute assignment of hundreds of Wisconsin National Guard members to assist with Election Day activities, and all of our cities re-assigned City staff from other departments to serve as poll workers and election officials and to assist with the myriad of tasks related to Election Day administration. The remainder of positions were staffed by high school students, college students, and members of the National Guard. Many of our poll workers had never worked an election before.

- **Green Bay:** The City needs to hire a total of 380 workers per election (total \$112,660). The City would like to pay poll workers more than they have previously received, to signify their importance in the process and to acknowledge the extra challenge it represents to serve as an election official during a pandemic. The City would like to increase poll worker salaries by 50% (additional \$56,330). All poll workers will be trained through the Wisconsin Elections Commission website and the City's own training manual (\$6,000). **Total: \$174,900**
- **Kenosha:** The City needs to hire 350 poll workers per election (\$100,000). They would like to offer hazard pay to increase pay to \$160/worker and \$220/chief inspectors (\$10,840). To aid in recruitment efforts, the City would like to hire a recruiter and liaison position for poll workers (\$35,000). **Total: \$145,840.**
- **Madison:** The City utilizes the election toolkit available through the MIT Technology Project to determine the staffing levels needed to ensure that voters will not have to wait in line for more than 15 minutes. In addition to the one Chief Inspector per polling location, Madison also has additional election officials who are certified as the Absentee Lead at each polling location. Madison estimates that if 75% of votes cast are absentee, the City will need 1,559 election officials at the polls in August. The City envisions a robust and strategic poll worker recruitment effort, focusing on people of color, high school students, and college students. The City would like to have resources for hazard pay for poll workers this fall at a rate comparable to what the U.S. Census is paying in the area

(\$369,788). The City has also found it challenging to convince facilities to host a polling location in the midst of a pandemic, and would like to provide each facility with a small amount of funds to compensate for their increased cleaning and sanitization costs (\$750/location, \$138,000 total). **Total: \$507,788**

- **Milwaukee:** The City plans to have 45 voting locations in August and to keep open as many of the normal 180 polling places as possible in November. August will require 3 chief inspectors per site and 20 election workers per site, for a total of 1200 election workers minimum and 150 chief inspectors. The City has a goal of recruiting 1,000 new election workers. The City would like to add an additional \$100 per worker in hazard pay to the poll workers' stipends of \$130 (\$460,000 additional for both elections) and \$100 hazard pay to chief inspector stipends of \$225 (\$87,750 additional for both elections). Additionally, the City of Milwaukee utilizes a Central Count of absentee ballots, which necessitates 15 chiefs and 200 election workers per election at Central Count (\$50,000/day for 2- days each election for a total of \$200,000). Total payroll for both elections will reach \$750,000 based upon these calculations. The City will launch a recruitment campaign for a new generation of election workers to sign up and be involved in their democracy, and hopes this effort can be included in the above request for resources for a marketing firm. Recruiting new and younger poll workers means that the Election Commission will need to innovate in election training. The Commission would like to produce polling place training videos (\$50,000) with live small-group, socially distanced discussions and Q&A sessions. These videos will augment existing training manuals. **Total: \$800,000**
- **Racine:** The City needs approximately 150 poll workers for August and 300 for November, in addition to 36 Chief Inspectors, and would like to pay all workers a \$100/election hazard pay (\$118,000 total payroll for both elections). City notes that its desire to have more early voting locations and hours is directly impacted by its ability to hire and train election officials. To that end, the City would like to launch a recruitment campaign that includes radio ads (\$1,000), ads on social media platforms (\$10,000), billboards in strategic City locations (\$5,000), and film videos for high school students in history/government classes (\$500). The City would also like to enlist a communication firm to: create a training video for election officials, develop an online quiz, detailed packets for election officials, and a PPE video filmed by a health professional about necessary COVID-19 precautions during all voting operations (\$22,000 total). Racine would also like to hire a liaison position to schedule, training and facilitate poll workers. (\$35,000) **Total: \$181,500.**

Recommendation III Total for All Strategies to Launch Poll Worker Recruitment, Training and Safety Efforts: \$1,810,028.00

Recommendation IV: Ensure Safe & Efficient Election Day Administration

It is no small task to mitigate risk of a lethal pandemic at all polling locations and throughout all required Election Day processing. Municipal clerks must ensure they have done everything possible to comply with public health guidelines and mitigate the risk of COVID-19 for all of the election officials, poll workers, observers, and voters. Our five municipalities are in need of numerous resources to both ensure seamless processing of voters on the upcoming Election Days, procure Personal Protective Equipment (PPE), disinfectant, and cleaning supplies to protect election officials and voters from the coronavirus, and to aid in processing of an expected high volume of absentee ballots. Additionally, as several of our municipalities move to add or expand drive-thru voting on Election Days, those expansions come with additional unbudgeted expenses for signage, tents, traffic control, publicity, and safety measures. All of our municipalities need resources to ensure that the remaining 2020 Election Days are administered seamlessly and safely.

- **Green Bay:** Green Bay would like to purchase 135 electronic poll books (\$2,100/each for a total of \$283,500) to reduce voter lines, facilitate Election Day Registrations and verification of photo ID. The City would also like a high speed tabulator (\$62,000) to count absentee ballots on Election Day, a ballot opener and ballot folder (\$5,000), and additional staff to process absentee ballots on Election Day (\$5,000). The City also needs masks, gloves, gowns, hair nets, face shields (\$15,000), cough/sneeze guards (\$43,000), and disinfectant supplies (\$3,000). **Total: \$426,500**
- **Kenosha:** The City would like to purchase automatic hand sanitizer dispensers for all polling locations (\$14,500) as well as PPE (gloves, masks, disinfectant, etc.) for all poll workers and voters (\$15,200). Kenosha would also like to be able to offer elderly residents and people with disabilities who wish to vote in person on Election Day two-way transportation, utilizing a local organization such as Care-A-Van (\$2,000). The City also needs resources for technology improvements to include a ballot opener, a ballot folder, 12 additional laptops and dymo printers, and high-speed scanner tabulators (\$172,000 total) to expedite election day processing and administration. **Total: \$203,700**
- **Madison:** The City needs hand sanitizer for all poll workers and voters, disinfectant spray, plexi-glass shields to allow poll workers to split the poll books, face shields for curbside election officials, and face masks for all poll workers and observers (\$20,000) as well as renting additional space to safely and accurately prepare all supplies and practice social distancing at the public test of election equipment (\$20,000) If the new voter registration form is not translated by the state into both Spanish and Hmong, Madison plans to translate the form (\$500). **Total: \$40,500**

- **Milwaukee:** The City will be purchasing 400 plexiglass barriers (\$55,000) for election workers at all polling location receiving and registration tables. Additionally, the Milwaukee Election Commission will need to acquire 400 face shields for workers not staffed behind plexiglass (\$4,000), gloves for all poll workers (\$3,000), masks on hand for election workers and members of the public (\$5,000), hand sanitizer (\$2,000) and disinfectant (\$2,000). Additionally, since Milwaukee also plans to offer curbside voting as an option at all polling places, updated, larger, more visible signage is necessary (\$5,000). **Total: \$76,000**
- **Racine:** Racine plans to issue all 36 wards its own PPE supply box which will each include masks, cleaning supplies, pens for each voter, gloves, hand sanitizer, safety vests, goggles, etc. (\$16,000). The City also needs large signs to direct and inform voters printed in English and Spanish (\$3,000). Additionally, the City would like to deploy a team of paid trained EDR Specialists for each polling location (\$10,000, including hourly pay, training expenses, and office supplies). As well, Racine would like iPads with cellular signal for each polling location to be able to easily verify voters' registration status and ward (\$16,000). The City would like to equip all wards with Badger Books (\$85,000); Racine began using electronic poll books in the February 2020 election and has found they dramatically increase and facilitate EDR, verification of voters' photo ID, expedite election processes, and reduce human error. **Total: \$130,000**

Recommendation IV Total for All Strategies to Ensure Safe & Efficient Election Day Administration: \$876,700.00

Conclusion

As Mayors in Wisconsin's five largest cities, we are committed to working collaboratively and innovatively to ensure that all of our residents can safely exercise their right to vote in 2020's remaining elections in the midst of the COVID-19 pandemic. The April 2020 election placed two of our most sacred duties in conflict: keeping our residents safe and administering free, fair, and inclusive elections. This Wisconsin Safe Voting Plan 2020 represents a remarkable and creative comprehensive plan, submitted collaboratively by all five of our cities. With sufficient resources, all five municipalities will swiftly, efficiently, and effectively implement the recommended strategies described in this plan, to ensure safe, fair, inclusive, secure, and professional elections in all of our communities this year.

From: Nuechterlein, Ellen Ellen.Nuechterlein@cityofracine.org
Subject: 2nd Mayors' Virtual Meeting - Doodle
Date: May 13, 2020 at 11:31 AM
To: APeterson@milwaukee.gov, terryso@greenbaywi.gov, mayor@kenosha.org, nholmes@cityofmadison.com



Good Morning!

I hope this finds you all well.

Mayor Mason would like to host another virtual meeting with Mayors Genrich, Antaramian, Rhodes-Conway and Barrett this Saturday. He said the 10 am time worked well, but if a different time will work, he is flexible. Please complete the Doodle Poll, and I will then send an Outlook appointment.

<https://doodle.com/poll/v3dds5nuea8838xi>

Thank you and stay safe,

Ellen
Ellen Nuechterlein
Executive Assistant, Office of the Mayor
730 Washington Ave., Racine WI 53403
Phone: 262-636-9111 / Fax: 636-9570



From: Paula Lattergrass plattergrass@kenosha.org 
Subject: Re: 2nd Mayors' Virtual Meeting - Doodle
Date: May 15, 2020 at 10:57 AM
To: Ellen Nuechterlein Ellen.Nuechterlein@cityofracine.org
Cc: Peterson, Alexis Alexis.Peterson@milwaukee.gov, nholmes@cityofmadison.com, terryso@greenbaywi.gov, mayor@kenosha.org



That works for Mayor Antaramian.

Paula Lattergrass

Executive Assistant to the Mayor
625 52nd Street Rm 300
Kenosha, Wisconsin 53140
T: 262.653.4000



From: "Ellen Nuechterlein" <Ellen.Nuechterlein@cityofracine.org>
To: "Peterson, Alexis" <Alexis.Peterson@milwaukee.gov>, nholmes@cityofmadison.com
Cc: terryso@greenbaywi.gov, mayor@kenosha.org
Sent: Friday, May 15, 2020 10:48:06 AM
Subject: RE: 2nd Mayors' Virtual Meeting - Doodle

Hi, Alexis.

For some reason Doodle is not showing your reply. That's what I get for using the free version ;-)

If 9:30 am would work for the Mayors, I can schedule it at that time. What does everyone think?

Thanks,

Ellen

From: Peterson, Alexis [mailto:Alexis.Peterson@milwaukee.gov]
Sent: Friday, May 15, 2020 10:39 AM
To: Nuechterlein, Ellen <Ellen.Nuechterlein@cityofracine.org>; nholmes@cityofmadison.com
Cc: terryso@greenbaywi.gov; mayor@kenosha.org
Subject: RE: 2nd Mayors' Virtual Meeting - Doodle

Mayor Barrett has a webinar panel at 10:30am – is there any chance this could occur at a different time. I'm sorry, I've been swamped and did reply to doodle poll.

Let me know.

Alexis Peterson | Special Assistant to the Mayor
Office of Mayor Tom Barrett
apeterson@milwaukee.gov

From: Nuechterlein, Ellen <Ellen.Nuechterlein@cityofracine.org>
Sent: Friday, May 15, 2020 10:28 AM
To: Peterson, Alexis <Alexis.Peterson@milwaukee.gov>; nholmes@cityofmadison.com
Cc: terryso@greenbaywi.gov; mayor@kenosha.org
Subject: RE: 2nd Mayors' Virtual Meeting - Doodle

Good morning, Alexis and Natasha.

I am following up to see if Mayor Barret and Mayor Rhodes-Conway are available tomorrow morning for a conversation. At this time, it appears that 10:00 and 11:00 a.m. are the options it has been narrowed down to. The Doodle link is below.

Thanks very much,

Ellen

From: Nuechterlein, Ellen
Sent: Wednesday, May 13, 2020 11:31 AM
To: APeterson@milwaukee.gov; terryso@greenbaywi.gov; mayor@kenosha.org; nholmes@cityofmadison.com
Subject: 2nd Mayors' Virtual Meeting - Doodle

Good Morning!

I hope this finds you all well.

Mayor Mason would like to host another virtual meeting with Mayors Genrich, Antaramian, Rhodes-Conway and Barrett this Saturday. He said the 10 am time worked well, but if a different time will work, he is flexible. Please complete the Doodle Poll, and I will then send an Outlook appointment.

<https://doodle.com/poll/v3dds5nuea8838xi>

Thank you and stay safe,

Ellen
Ellen Nuechterlein
Executive Assistant, Office of the Mayor
730 Washington Ave., Racine WI 53403
Phone: 262-636-9111 / Fax: 636-9570



The City of Milwaukee is subject to Wisconsin Statutes related to public records. Unless otherwise exempted from the public records law, senders and receivers of City of Milwaukee e-mail should presume that e-mail is subject to release upon request and is

00466

MILWAUKEE E-MAIL SHOULD PRESUME THAT E-MAIL IS SUBJECT TO RELEASE UPON REQUEST, AND IS
subject to state records retention requirements. See City of Milwaukee full e-mail disclaimer
at www.milwaukee.gov/email_disclaimer

From: Terry Sorelle [<mailto:Terry.Sorelle@greenbaywi.gov>]
Sent: Friday, May 15, 2020 11:08 AM
To: 'Paula Lattergrass' <plattergrass@kenosha.org>; Nuechterlein, Ellen <Ellen.Nuechterlein@cityofracine.org>
Cc: Peterson, Alexis <Alexis.Peterson@milwaukee.gov>; nholmes@cityofmadison.com; mayor@kenosha.org
Subject: RE: 2nd Mayors' Virtual Meeting - Doodle

That works for Mayor Genrich. Thanks!



Terry Sorelle
Executive Secretary to the Mayor
Mayor's Office
920-448-3005

From: Paula Lattergrass [<mailto:plattergrass@kenosha.org>]
Sent: Friday, May 15, 2020 10:57 AM
To: Ellen Nuechterlein
Cc: Peterson, Alexis; nholmes@cityofmadison.com; Terry Sorelle; mayor@kenosha.org
Subject: Re: 2nd Mayors' Virtual Meeting - Doodle

That works for Mayor Antaramian.

Paula Lattergrass
Executive Assistant to the Mayor
625 52nd Street Rm 300
Kenosha, Wisconsin 53140
T: 262.653.4000

From: "Ellen Nuechterlein" <Ellen.Nuechterlein@cityofracine.org>
To: "Peterson, Alexis" <Alexis.Peterson@milwaukee.gov>, nholmes@cityofmadison.com
Cc: terryso@greenbaywi.gov, mayor@kenosha.org
Sent: Friday, May 15, 2020 10:48:06 AM
Subject: RE: 2nd Mayors' Virtual Meeting - Doodle

Hi, Alexis.

For some reason Doodle is not showing your reply. That's what I get for using the free version ;-)

15:00:00

If 9:30 am would work for the Mayors, I can schedule it at that time. What does everyone think?

Thanks,

Ellen

From: Peterson, Alexis [<mailto:Alexis.Peterson@milwaukee.gov>]
Sent: Friday, May 15, 2020 10:39 AM
To: Nuechterlein, Ellen <Ellen.Nuechterlein@cityofracine.org>; nholmes@cityofmadison.com
Cc: terryso@greenbaywi.gov; mayor@kenosha.org
Subject: RE: 2nd Mayors' Virtual Meeting - Doodle

Mayor Barrett has a webinar panel at 10:30am – is there any chance this could occur at a different time. I'm sorry, I've been swamped and did reply to doodle poll.

Let me know.

Alexis Peterson | Special Assistant to the Mayor
Office of Mayor Tom Barrett
apeterson@milwaukee.gov

From: Nuechterlein, Ellen <Ellen.Nuechterlein@cityofracine.org>
Sent: Friday, May 15, 2020 10:28 AM
To: Peterson, Alexis <Alexis.Peterson@milwaukee.gov>; nholmes@cityofmadison.com
Cc: terryso@greenbaywi.gov; mayor@kenosha.org
Subject: RE: 2nd Mayors' Virtual Meeting - Doodle

Good morning, Alexis and Natasha.

I am following up to see if Mayor Barret and Mayor Rhodes-Conway are available tomorrow morning for a conversation. At this time, it appears that 10:00 and 11:00 a.m. are the options it has been narrowed down to. The Doodle link is below.

Thanks very much,

Ellen

From: Nuechterlein, Ellen
Sent: Wednesday, May 13, 2020 11:31 AM
To: APeterson@milwaukee.gov; terryso@greenbaywi.gov; mayor@kenosha.org; nholmes@cityofmadison.com
Subject: 2nd Mayors' Virtual Meeting - Doodle

Good Morning!

I hope this finds you all well.

Mayor Mason would like to host another virtual meeting with Mayors Genrich, Antaramian, Rhodes-Conway and Barrett this Saturday. He said the 10 am time worked well, but if a different time will work, he is flexible. Please complete the Doodle Poll, and I will then send an Outlook appointment.

<https://doodle.com/poll/v3dds5nuea8838xi>

Thank you and stay safe,

Ellen
Ellen Nuechterlein
Executive Assistant, Office of the Mayor
730 Washington Ave., Racine WI 53403
Phone: 262-636-9111 / Fax: 636-9570



The City of Milwaukee is subject to Wisconsin Statutes related to public records. Unless otherwise exempted from the public records law, senders and receivers of City of Milwaukee e-mail should presume that e-mail is subject to release upon request, and is subject to state records retention requirements. See City of Milwaukee full e-mail disclaimer at www.milwaukee.gov/email_disclaimer

From: Terry Sorelle Terry.Sorelle@greenbaywi.gov 
Subject: RE: 2nd Mayors' Virtual Meeting - Doodle
Date: May 15, 2020 at 11:25 AM
To: Paula Lattergrass plattergrass@kenosha.org, Ellen Nuechterlein Ellen.Nuechterlein@cityofracine.org
Cc: Peterson, Alexis Alexis.Peterson@milwaukee.gov, nholmes@cityofmadison.com, mayor@kenosha.org



That works for Mayor Genrich. Thanks!



Terry Sorelle
Executive Secretary to the Mayor
Mayor's Office
920-448-3005

From: Paula Lattergrass [mailto:plattergrass@kenosha.org]
Sent: Friday, May 15, 2020 10:57 AM
To: Ellen Nuechterlein
Cc: Peterson, Alexis; nholmes@cityofmadison.com; Terry Sorelle; mayor@kenosha.org
Subject: Re: 2nd Mayors' Virtual Meeting - Doodle

That works for Mayor Antaramian.

Paula Lattergrass
Executive Assistant to the Mayor
625 52nd Street Rm 300
Kenosha, Wisconsin 53140
T: 262.653.4000

From: "Ellen Nuechterlein" <Ellen.Nuechterlein@cityofracine.org>
To: "Peterson, Alexis" <Alexis.Peterson@milwaukee.gov>, nholmes@cityofmadison.com
Cc: terryso@greenbaywi.gov, mayor@kenosha.org
Sent: Friday, May 15, 2020 10:48:06 AM
Subject: RE: 2nd Mayors' Virtual Meeting - Doodle

Hi, Alexis.

For some reason Doodle is not showing your reply. That's what I get for using the free version ;-)

If 9:30 am would work for the Mayors, I can schedule it at that time. What does everyone think?

Thanks,

Ellen

00471

From: Peterson, Alexis [mailto:Alexis.Peterson@milwaukee.gov]
Sent: Friday, May 15, 2020 10:39 AM
To: Nuechterlein, Ellen <Ellen.Nuechterlein@cityofracine.org>; nholmes@cityofmadison.com
Cc: terryso@greenbaywi.gov; mayor@kenosha.org
Subject: RE: 2nd Mayors' Virtual Meeting - Doodle

Mayor Barrett has a webinar panel at 10:30am – is there any chance this could occur at a different time. I'm sorry, I've been swamped and did reply to doodle poll.

Let me know.

Alexis Peterson | Special Assistant to the Mayor
Office of Mayor Tom Barrett
apeterson@milwaukee.gov

From: Nuechterlein, Ellen <Ellen.Nuechterlein@cityofracine.org>
Sent: Friday, May 15, 2020 10:28 AM
To: Peterson, Alexis <Alexis.Peterson@milwaukee.gov>; nholmes@cityofmadison.com
Cc: terryso@greenbaywi.gov; mayor@kenosha.org
Subject: RE: 2nd Mayors' Virtual Meeting - Doodle

Good morning, Alexis and Natasha.

I am following up to see if Mayor Barret and Mayor Rhodes-Conway are available tomorrow morning for a conversation. At this time, it appears that 10:00 and 11:00 a.m. are the options it has been narrowed down to. The Doodle link is below.

Thanks very much,

Ellen

From: Nuechterlein, Ellen
Sent: Wednesday, May 13, 2020 11:31 AM
To: APeterson@milwaukee.gov; terryso@greenbaywi.gov; mayor@kenosha.org;
nholmes@cityofmadison.com
Subject: 2nd Mayors' Virtual Meeting - Doodle

Good Morning!

I hope this finds you all well.

Mayor Mason would like to host another virtual meeting with Mayors Genrich, Antaramian, Rhodes-Conway and Barrett this Saturday. He said the 10 am time worked well, but if a different time will work, he is flexible. Please complete the Doodle Poll, and I will then send an Outlook appointment.

<https://doodle.com/poll/v3dds5nuea8838xi>

Thank you and stay safe.

00472

Ellen
Ellen Nuechterlein
Executive Assistant, Office of the Mayor
730 Washington Ave., Racine WI 53403
Phone: 262-636-9111 / Fax: 636-9570



The City of Milwaukee is subject to Wisconsin Statutes related to public records. Unless otherwise exempted from the public records law, senders and receivers of City of Milwaukee e-mail should presume that e-mail is subject to release upon request, and is subject to state records retention requirements. See City of Milwaukee full e-mail disclaimer at www.milwaukee.gov/email_disclaimer

From: Nuechterlein, Ellen Ellen.Nuechterlein@cityofracine.org
Subject: RE: 2nd Mayors' Virtual Meeting - Doodle
Date: May 15, 2020 at 12:58 PM
To: Terry Sorelle Terry.Sorelle@greenbaywi.gov, Paula Lattergrass plattergrass@kenosha.org
Cc: Peterson, Alexis Alexis.Peterson@milwaukee.gov, nholmes@cityofmadison.com, mayor@kenosha.org



Mayor Mason heard directly from Mayor Rhodes-Conway is also available at 9:30 am tomorrow. I will send the appointment out shortly.

Thanks very much, and have a relaxing weekend.

Ellen
Ellen Nuechterlein
Executive Assistant, Office of the Mayor
730 Washington Ave., Racine WI 53403
Phone: 262-636-9111 / Fax: 636-9570



From: Terry Sorelle [mailto:Terry.Sorelle@greenbaywi.gov]
Sent: Friday, May 15, 2020 11:08 AM
To: 'Paula Lattergrass' <plattergrass@kenosha.org>; Nuechterlein, Ellen <Ellen.Nuechterlein@cityofracine.org>
Cc: Peterson, Alexis <Alexis.Peterson@milwaukee.gov>; nholmes@cityofmadison.com; mayor@kenosha.org
Subject: RE: 2nd Mayors' Virtual Meeting - Doodle

That works for Mayor Genrich. Thanks!



Terry Sorelle
Executive Secretary to the Mayor
Mayor's Office
920-448-3005

From: Paula Lattergrass [mailto:plattergrass@kenosha.org]
Sent: Friday, May 15, 2020 10:57 AM
To: Ellen Nuechterlein
Cc: Peterson, Alexis; nholmes@cityofmadison.com; Terry Sorelle; mayor@kenosha.org
Subject: Re: 2nd Mayors' Virtual Meeting - Doodle

That works for Mayor Antaramian.

Paula Lattergrass
Executive Assistant to the Mayor
625 52nd Street Rm 300

00474

Kenosha, Wisconsin 53140
T: 262.653.4000

From: "Ellen Nuechterlein" <Ellen.Nuechterlein@cityofracine.org>
To: "Peterson, Alexis" <Alexis.Peterson@milwaukee.gov>, nholmes@cityofmadison.com
Cc: terryso@greenbaywi.gov, mayor@kenosha.org
Sent: Friday, May 15, 2020 10:48:06 AM
Subject: RE: 2nd Mayors' Virtual Meeting - Doodle

Hi, Alexis.

For some reason Doodle is not showing your reply. That's what I get for using the free version ;-)

If 9:30 am would work for the Mayors, I can schedule it at that time. What does everyone think?

Thanks,

Ellen

From: Peterson, Alexis [<mailto:Alexis.Peterson@milwaukee.gov>]
Sent: Friday, May 15, 2020 10:39 AM
To: Nuechterlein, Ellen <Ellen.Nuechterlein@cityofracine.org>; nholmes@cityofmadison.com
Cc: terryso@greenbaywi.gov; mayor@kenosha.org
Subject: RE: 2nd Mayors' Virtual Meeting - Doodle

Mayor Barrett has a webinar panel at 10:30am – is there any chance this could occur at a different time. I'm sorry, I've been swamped and did reply to doodle poll.

Let me know.

Alexis Peterson | Special Assistant to the Mayor
Office of Mayor Tom Barrett
apeterson@milwaukee.gov

From: Nuechterlein, Ellen <Ellen.Nuechterlein@cityofracine.org>
Sent: Friday, May 15, 2020 10:28 AM
To: Peterson, Alexis <Alexis.Peterson@milwaukee.gov>; nholmes@cityofmadison.com
Cc: terryso@greenbaywi.gov; mayor@kenosha.org
Subject: RE: 2nd Mayors' Virtual Meeting - Doodle

00475

Good morning, Alexis and Natasha.

I am following up to see if Mayor Barret and Mayor Rhodes-Conway are available tomorrow morning for a conversation. At this time, it appears that 10:00 and 11:00 a.m. are the options it has been narrowed down to. The Doodle link is below.

Thanks very much,

Ellen

From: Nuechterlein, Ellen

Sent: Wednesday, May 13, 2020 11:31 AM

To: APeterson@milwaukee.gov; terryso@greenbaywi.gov; mayor@kenosha.org; nholmes@cityofmadison.com

Subject: 2nd Mayors' Virtual Meeting - Doodle

Good Morning!

I hope this finds you all well.

Mayor Mason would like to host another virtual meeting with Mayors Genrich, Antaramian, Rhodes-Conway and Barrett this Saturday. He said the 10 am time worked well, but if a different time will work, he is flexible. Please complete the Doodle Poll, and I will then send an Outlook appointment.

<https://doodle.com/poll/v3dds5nuea8838xi>

Thank you and stay safe,

Ellen

Ellen Nuechterlein

Executive Assistant, Office of the Mayor

730 Washington Ave., Racine WI 53403

Phone: 262-636-9111 / Fax: 636-9570



The City of Milwaukee is subject to Wisconsin Statutes related to public records. Unless otherwise exempted from the public records law, senders and receivers of City of Milwaukee e-mail should presume that e-mail is subject to release upon request, and is subject to state records retention requirements. See City of Milwaukee full e-mail disclaimer at www.milwaukee.gov/email_disclaimer

00476

From: Nuechterlein, Ellen Ellen.Nuechterlein@cityofracine.org 
Subject: RE: 2nd Mayors' Virtual Meeting - Doodle
Date: May 15, 2020 at 1:09 PM
To: Peterson, Alexis Alexis.Peterson@milwaukee.gov, Terry Sorelle Terry.Sorelle@greenbaywi.gov, Paula Lattergrass plattergrass@kenosha.org
Cc: nholmes@cityofmadison.com, mayor@kenosha.org

Thanks very much, Alexis.

Ellen

From: Peterson, Alexis [<mailto:Alexis.Peterson@milwaukee.gov>]
Sent: Friday, May 15, 2020 1:01 PM
To: Nuechterlein, Ellen <Ellen.Nuechterlein@cityofracine.org>; Terry Sorelle <Terry.Sorelle@greenbaywi.gov>; 'Paula Lattergrass' <plattergrass@kenosha.org>
Cc: nholmes@cityofmadison.com; mayor@kenosha.org
Subject: RE: 2nd Mayors' Virtual Meeting - Doodle

Ok, I will make that work. I texted the Mayor but have not had a chance to talk to him in a bit.

Thank you,

Alexis Peterson | Special Assistant to the Mayor
Office of Mayor Tom Barrett
apeterson@milwaukee.gov

From: Nuechterlein, Ellen <Ellen.Nuechterlein@cityofracine.org>
Sent: Friday, May 15, 2020 12:59 PM
To: Terry Sorelle <Terry.Sorelle@greenbaywi.gov>; 'Paula Lattergrass' <plattergrass@kenosha.org>
Cc: Peterson, Alexis <Alexis.Peterson@milwaukee.gov>; nholmes@cityofmadison.com; mayor@kenosha.org
Subject: RE: 2nd Mayors' Virtual Meeting - Doodle

Mayor Mason heard directly from Mayor Rhodes-Conway is also available at 9:30 am tomorrow. I will send the appointment out shortly.

Thanks very much, and have a relaxing weekend.

Ellen
Ellen Nuechterlein
Executive Assistant, Office of the Mayor
730 Washington Ave., Racine WI 53403
Phone: 262-636-9111 / Fax: 636-9570



From: Nuechterlein, Ellen Ellen.Nuechterlein@cityofracine.org

Subject: Availability: Virtual Call with Mayors

Date: June 9, 2020 at 9:28 AM

To: Terry Sorelle Terry.Sorelle@greenbaywi.gov, Holmes, Natasha NHolmes@cityofmadison.com, Paula Lattergrass plattergrass@kenosha.org, Peterson, Alexis Alexis.Peterson@milwaukee.gov

Good morning.

I hope your week is off to a good start! Mayor Mason would like to convene another virtual meeting with the Mayors this Saturday, June 13. The Elections Administration Planning Grant will be discussed.

Please reply to the Doodle Poll with your respective Mayor's availability, and I will send an Outlook appointment with a Zoom link later this week.

<https://doodle.com/poll/3se9b4cah6ydg67s>

Thanks very much and be well,

Ellen

Ellen Nuechterlein

Executive Assistant, Office of the Mayor

730 Washington Ave., Racine WI 53403

Phone: 262-636-9111 / Fax: 636-9570



From: Terry Sorelle Terry.Sorelle@greenbaywi.gov
Subject: RE: Availability for Mayors' Virtual Meeting Saturday Morning
Date: August 13, 2020 at 3:16 PM
To: Nuechterlein, Ellen Ellen.Nuechterlein@cityofracine.org, LDCosta@cityofmadison.com, Paula Lattergrass plattergrass@kenosha.org, mayor@kenosha.org, Vornholt, Paul (Paul.Vornholt@milwaukee.gov) Paul.Vornholt@milwaukee.gov



Mayor Genrich is available all the times, thanks!



Terry Sorelle
Executive Secretary to the Mayor
Mayor's Office
920-448-3005

From: Nuechterlein, Ellen [mailto:Ellen.Nuechterlein@cityofracine.org]
Sent: Thursday, August 13, 2020 12:45 PM
To: LDCosta@cityofmadison.com; Terry Sorelle; Paula Lattergrass ; mayor@kenosha.org; Vornholt, Paul (Paul.Vornholt@milwaukee.gov)
Subject: Availability for Mayors' Virtual Meeting Saturday Morning

Good afternoon!

I hope you are all well on this sunny "Friday Eve."

Mayor Mason has asked me to schedule another virtual meeting for our five Mayors this Saturday morning. Please let me know what time works best, and I will send an Outlook appointment out. (If there is no strong preference, I will schedule it for 10:00.)

- 9:00 am
- 9:30 am
- 10:00 am
- 10:30 am
- 11:00 am

Thanks very much,

Ellen
Ellen Nuechterlein
Executive Assistant, Office of the Mayor
730 Washington Ave., Racine WI 53403
Phone: 262-636-9111 / Fax: 636-9570



From: Stevens, Nicole NStevens@cityofmadison.com
Subject: RE: Availability for Mayors' Virtual Meeting Saturday Morning
Date: August 14, 2020 at 10:00 AM
To: Nuechterlein, Ellen Ellen.Nuechterlein@cityofracine.org, Terry Sorelle TerrySo@greenbaywi.gov, Paula Lattergrass plattergrass@kenosha.org, mayor@kenosha.org, Vornholt, Paul (Paul.Vornholt@milwaukee.gov) Paul.Vornholt@milwaukee.gov



Good morning Ellen,

Mayor Rhodes-Conway is available tomorrow, Saturday, August 15th at 10:00am.

Thank you and happy Friday!

Nicole



Nicole Stevens, Executive Assistant to the Mayor
Office of Mayor Satya Rhodes-Conway
Room 403, City-County Building
210 Martin Luther King, Jr. Blvd.
Madison, Wisconsin 53703
Tel 608 266 4611 • **Fax** 608 267 8671
Email nstevens@cityofmadison.com
Web <http://www.cityofmadison.com/mayor/>

From: DCosta, Laila <LDCosta@cityofmadison.com>
Sent: Thursday, August 13, 2020 4:48 PM
To: 'Nuechterlein, Ellen' <Ellen.Nuechterlein@cityofracine.org>; Terry Sorelle <TerrySo@greenbaywi.gov>; Paula Lattergrass <plattergrass@kenosha.org>; mayor@kenosha.org; Vornholt, Paul (Paul.Vornholt@milwaukee.gov) <Paul.Vornholt@milwaukee.gov>
Cc: Stevens, Nicole <NStevens@cityofmadison.com>
Subject: RE: Availability for Mayors' Virtual Meeting Saturday Morning

Hi Ellen (and everyone),

We are checking on Mayor Rhodes-Conway's schedule and will get back to you as soon as we can. I am cc'ing Nicole Stevens as she is now handling Mayor Rhodes-Conway's schedule going forward.

Thanks so much! And, happy Friday Eve to all of you.

Laila

>>> The 2020 Census is here! As we practice social distancing, take the opportunity to complete the census now from the comfort of your own home. You can fill it out online at my2020census.gov, by phone, or by mail. <<<

Laila D'Costa
Office of the Mayor
City-County Bldg., Rm. 403
210 Martin Luther King, Jr. Blvd.
Madison, WI 53703-3345

00480

608-266-4434

From: Nuechterlein, Ellen <Ellen.Nuechterlein@cityofracine.org>
Sent: Thursday, August 13, 2020 12:45 PM
To: DCosta, Laila <LDCosta@cityofmadison.com>; Terry Sorelle <TerrySo@greenbaywi.gov>; Paula Plattergrass <plattergrass@kenosha.org>; mayor@kenosha.org; Vornholt, Paul (Paul.Vornholt@milwaukee.gov) <Paul.Vornholt@milwaukee.gov>
Subject: Availability for Mayors' Virtual Meeting Saturday Morning

Caution: This email was sent from an external source. Avoid unknown links and attachments.

Good afternoon!

I hope you are all well on this sunny "Friday Eve."

Mayor Mason has asked me to schedule another virtual meeting for our five Mayors this Saturday morning. Please let me know what time works best, and I will send an Outlook appointment out. (If there is no strong preference, I will schedule it for 10:00.)

- 9:00 am
- 9:30 am
- 10:00 am
- 10:30 am
- 11:00 am

Thanks very much,

Ellen
Ellen Nuechterlein
Executive Assistant, Office of the Mayor
730 Washington Ave., Racine WI 53403
Phone: 262-636-9111 / Fax: 636-9570



00481

From: Paula Lattergrass plattergrass@kenosha.org
Subject: Re: Availability for Mayors' Virtual Meeting Saturday Morning
Date: August 14, 2020 at 10:54 AM
To: Ellen Nuechterlein Ellen.Nuechterlein@cityofracine.org
Cc: LDCosta@cityofmadison.com, Terry Sorelle TerrySo@greenbaywi.gov, mayor@kenosha.org, Vornholt, Paul (Paul.Vornholt@milwaukee.gov) Paul.Vornholt@milwaukee.gov



Good morning, Ellen; Mayor Antaramian is available at any of these times.

Paula Lattergrass

Executive Assistant to the Mayor
625 52nd Street Km 300
Kenosha, Wisconsin 53140
T: 262.653.4000



From: "Ellen Nuechterlein" <Ellen.Nuechterlein@cityofracine.org>
To: LDCosta@cityofmadison.com, "Terry Sorelle" <TerrySo@greenbaywi.gov>, "Paula Lattergrass" <plattergrass@kenosha.org>, mayor@kenosha.org, "Vornholt, Paul (Paul.Vornholt@milwaukee.gov)" <Paul.Vornholt@milwaukee.gov>
Sent: Thursday, August 13, 2020 12:45:00 PM
Subject: Availability for Mayors' Virtual Meeting Saturday Morning

Good afternoon!

I hope you are all well on this sunny "Friday Eve."

Mayor Mason has asked me to schedule another virtual meeting for our five Mayors this Saturday morning. Please let me know what time works best, and I will send an Outlook appointment out. (If there is no strong preference, I will schedule it for 10:00.)

- 9:00 am
- 9:30 am
- 10:00 am
- 10:30 am
- 11:00 am

Thanks very much,

Ellen
Ellen Nuechterlein
Executive Assistant, Office of the Mayor
730 Washington Ave., Racine WI 53403
Phone: 262-636-9111 / Fax: 636-9570

